

Glenair®



MIL-DTL-38999 Cylindrical Connectors

Hermetics, Filters, Environmentals, Feed-Thrus, Lanyards, Sav-Cons® and More!

United States ■ United Kingdom ■ Germany ■ France ■ Nordic ■ Italy ■ Spain ■ Japan

1st Edition • September, 2008

1000 Hour Grey™

The Advanced Formula Ni-PTFE Plating Process for EMC Applications



**New Cadmium Free
RoHS Compliant
Plating Process Breaks
1000 Hour Corrosion
Protection Barrier!**

The MIL-DTL-38999 Rev. L detail specification establishes several new cadmium-free conductive plating options including high-performance nickel-fluorocarbon polymer. The Glenair advanced formula **1000 Hour Grey™** plating process (Ni-PTFE) meets all D38999 performance requirements including a shell-to-shell conductivity maximum 2.5 millivolt drop potential.

1000 Hour Grey™ delivers outstanding performance in a broad range of land, sea, air and space interconnect applications. The non-reflective, non-magnetic, gun-metal gray surface finish is an ideal choice for tactical military systems with extraordinary corrosion protection and EMC requirements.

Advanced Durability, Lubricity Plus Outstanding Temperature Resistance!

The mechanical, electrical and environmental performance of **1000 Hour Grey™** is truly outstanding, far surpassing that of other metal alloy/fluorocarbon polymer plating solutions:

- 1000+ Hrs. Salt Spray
- Max 2.5 Millivolt Drop Potential
- -65°C to 175°C Temp. Rating
- 336+ Hrs. Sulfur Dioxide Resistance
- Non-Magnetic
- Cadmium Free
- Low Coefficient of Friction
- Hexavalent Chromium Free
- Potassium Formate Resistant
- Low Shell-to-Shell Resistance
- Adheres to Composite Plastic
- 500+ Mating Cycles
- Low Outgassing
- Available Now!



Glenair, Inc.

1211 Air Way • Glendale, CA 91201-2497 • Tel: 818-247-6000 • Fax: 818-500-9912 • E-Mail: sales@glenair.com

MIL-DTL-38999

Qualified Connectors and Derivatives

A Introduction to MIL-DTL-38999 Cylindrical Connectors



A

B Hermetic Connectors



B

C EMI/EMP Filter Connectors

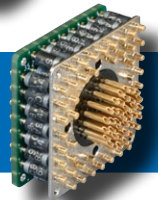

C

D Environmental Connectors



D

E Twinax and Quadrax Connectors

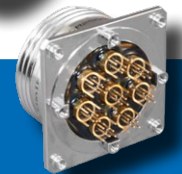

E

F Bulkhead Feed-Thrus



F

G Sav-Con® Connector Savers



G

H Connector Accessories and Tools



H

Turn to Individual Sections for Detailed Table of Contents



MIL-DTL-38999 Environmental Class Connectors Overview

Series I

MIL-DTL-38999 Environmental Class Connector Overview

MIL-DTL-38999 is a high-performance connector family designed for cable-to-panel I/O applications in military aerospace and other demanding situations. Environmental class plugs and receptacles—with high-density insert arrangements (up to 128 contacts)—are available with crimp removable contacts, PC tails, and solder cups. Glenair manufactures a wide range of environmental class MIL-DTL-38999 type connectors including lanyard-release products, composite and specialty metal cable plugs and receptacles, and Coax contact equipped products. This table describes the most basic attributes for the environmental class products supplied by Glenair.

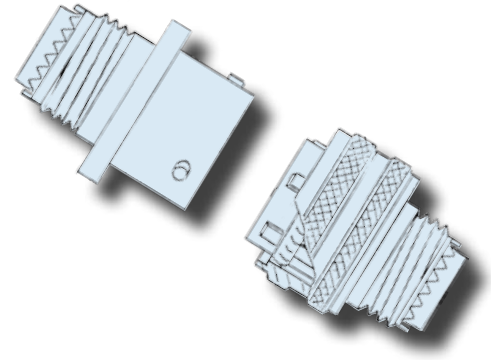

Series Description

Scoop-Proof 3-Point Bayonet Coupling

Supported Contact Types and Gauges

12, 16, 20, and 22 gauge contacts, standard density and 22 gauge high density arrangements; 3 to 128 contacts. Crimp, solder and PCB tails.

Coupling/Mating Design

Bayonet coupling; quick disconnect; positive locking, keyed.

EMI Shielding

Conductive plating and thick shell wall cross-sections provide effective EMI shielding to 40 dB minimum at 10 GHz.

Vibration and Shock

Excellent resistance to vibration and shock with no electrical discontinuity and no disengagement of the mated connectors per MIL-DTL-38999 (paragraph 3.26)

Mating Speed

120 ° or 1/3 turn to full mate

Materials

Aluminum, Composite or Stainless Shells, Silicone Seals per ZZ-R-765, Beryllium Copper Alloy, Gold Plated Contacts

**MIL-DTL-38999
Environmental Class Connectors
Overview**



Series II	Series III	Series IV
------------------	-------------------	------------------

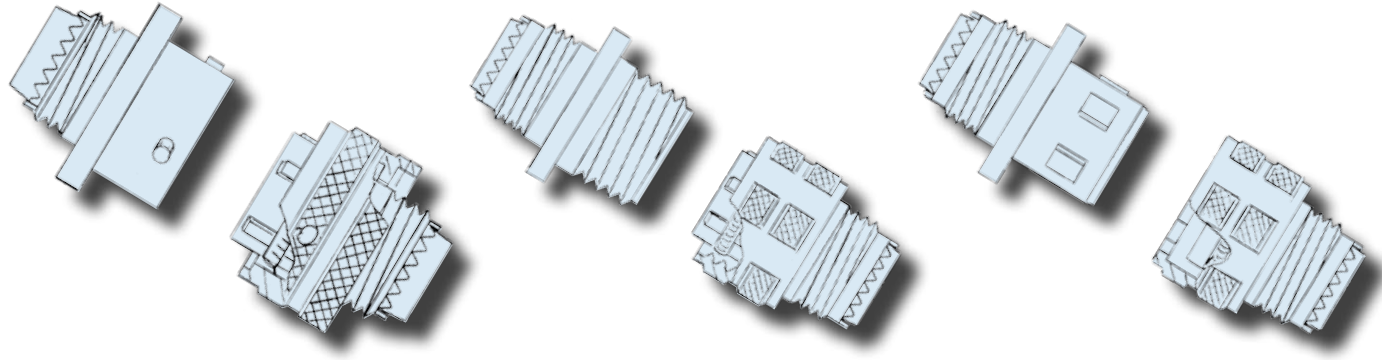

<p>Low-Profile 3-Point Bayonet Coupling</p> <p>12, 16, 20, and 22 gauge contacts, standard density and 22 gauge high density arrangements; 3 to 128 contacts. Crimp, solder and PCB tails.</p>	<p>Scoop-Proof, Triple Start, Self-Locking</p> <p>12, 16, 20, and 22 gauge contacts, standard density and 22 gauge high density arrangements; 3 to 128 contacts. Crimp, solder and PCB tails.</p>	<p>Scoop-Proof, Breech Lock</p> <p>12, 16, 20, and 22 gauge contacts, standard density and 22 gauge high density arrangements; 3 to 128 contacts. Crimp, solder and PCB tails.</p>
<p>Bayonet coupling design, quick disconnect, captive, keyed.</p>	<p>Triple-start threaded coupling design, rapid advance, self-locking and full-mate indicator, keyed.</p>	<p>Breech lock coupling design, rapid advance, self-locking, keyed.</p>
<p>Conductive plating and thick shell wall cross-sections provide effective EMI shielding to 40 dB minimum at 10 GHz.</p>	<p>Shell to shell bottoming, grounding fingers, conductive plating and thick shell wall cross-sections provide effective EMI shielding to 65 dB minimum at 10 GHz</p>	<p>Shell to shell bottoming, grounding fingers, conductive plating and thick shell wall cross-sections provide effective EMI shielding to 65 dB minimum at 10 GHz. Grounding before engagement of contacts.</p>
<p>Excellent resistance to vibration and shock with no electrical discontinuity and no disengagement of the mated connectors per MIL-DTL-38999 (paragraph 3.26)</p>	<p>Excellent resistance to vibration and shock with no electrical discontinuity and no disengagement of the mated connectors per MIL-DTL-38999 (paragraph 3.26)</p>	<p>Excellent resistance to vibration and shock with no electrical discontinuity and no disengagement of the mated connectors per MIL-DTL-38999 (paragraph 3.26)</p>
<p>120 ° or 1/3 turn to full mate</p>	<p>360 ° or one full turn to full mate</p>	<p>90° or 1/4 turn to full mate</p>
<p>Aluminum or Stainless Steel Shells, Silicone Seals per ZZ-R-765, Beryllium Copper Alloy, Gold Plated Contacts</p>	<p>Aluminum, CRES and Composite Shells, Silicone Seals per ZZ-R-765, Beryllium Copper Alloy, Gold Plated Contacts</p>	<p>Aluminum Shells, Silicone Seals per ZZ-R-765, Beryllium Copper Alloy, Gold Plated Contacts</p>



MIL-DTL-38999 Hermetic Connectors

Hermetic connectors, such as the qualified MIL-DTL-38999 Series I, II, III and IV supplied by Glenair, are designed for use in pressurized or severe environmental applications. Typical environments include geophysical, medical and military aerospace—in fact, the requirement for connector hermeticity was originally driven by military electronic applications. Hermeticity is generally defined as the state or condition of being air or gas tight. In interconnect

Glenair typically specifies stainless steel, carbon steel, titanium or Kovar for its hermetic products to provide an effective barrier against gas ingress and corrosion caused by dew point condensation. The hermetic sealing helps insure against damage to sensitive electronic systems and components.

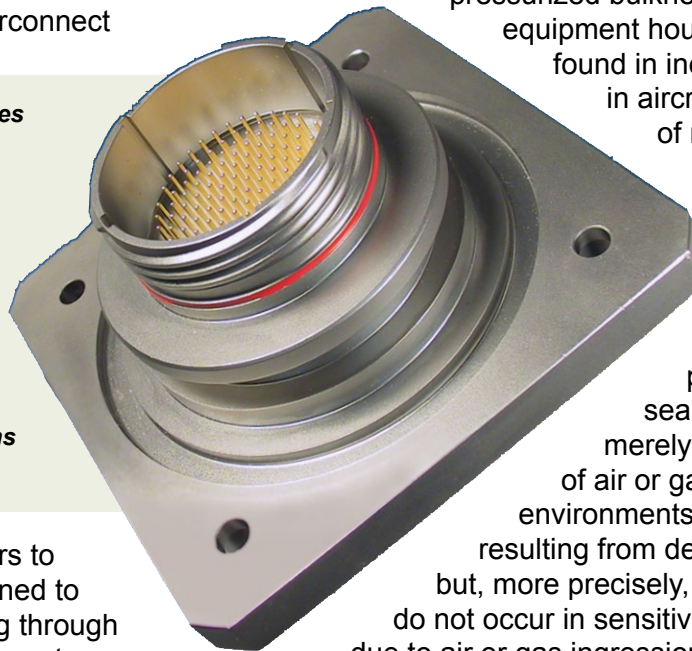

applications, “hermetic” refers to packaging technology designed to prevent gasses from passing through pressure barriers via the connector, as it is important to prevent any moisture in the leaked gas from condensing inside the pressurized enclosure. The point at which moisture will condense is called the “dew point”—or the precise moment when humidity, pressure, and temperature allows condensation to form.

When an electric current must pass through a high-pressure differential barrier, the potential exists for gases, and, in some rare cases, particulate matter, to penetrate the barrier and, as described above, to form condensation in the equipment enclosure. In the receptacle cabling on the vacuum side of the barrier this may result

in dielectric breakdown, corrosion, and loss of insulation resistance between conductors (a properly built plug assembly on the non-vacuum side is adequately sealed with conventional environmental protections and so is impervious to moisture ingress).

The classic hermetic application is a receptacle feed-through penetrating a pressurized bulkhead, or a pressurized equipment housing—such as is found in inertial navigation units in aircraft. The introduction of moisture-laden air into such an enclosure may be enough to produce false readings and other malfunctions in the device. The ultimate purpose of hermetic sealing then is not merely to avert the ingress of air or gas into pressurized environments to prevent corrosion resulting from dew point condensation, but, more precisely, to insure malfunctions do not occur in sensitive electronic systems due to air or gas ingressions.

Connector hermeticity may be negatively affected both by the permeability of shell materials and the quality of the sealing technology. Metal materials are typically chosen due to their relative impermeability to gas, although certain plastics may also be used. Glenair typically specifies stainless steel, carbon steel, titanium or Kovar for its hermetic products, as all these base materials provide an effective barrier against gas ingress.

But even metal materials are permeable to gas leakage to some degree, and the minimal permeability of metal materials can be worsened when weld and solder joints are formed between

MIL-DTL-38999 Hermetic Connectors Overview



connector shell materials and the base material of the bulkhead. Electrode coatings used in welding readily attract moisture in the work causing micro cracks and fissures. If other stresses are present, such as vibration and shock, micro-cracking can progress to larger fissures visible to the human eye. Optimizing hermeticity should therefore always include examination of welds for any cracks or fissures that could provide a leakage path. Although moderately effective sealing may be produced

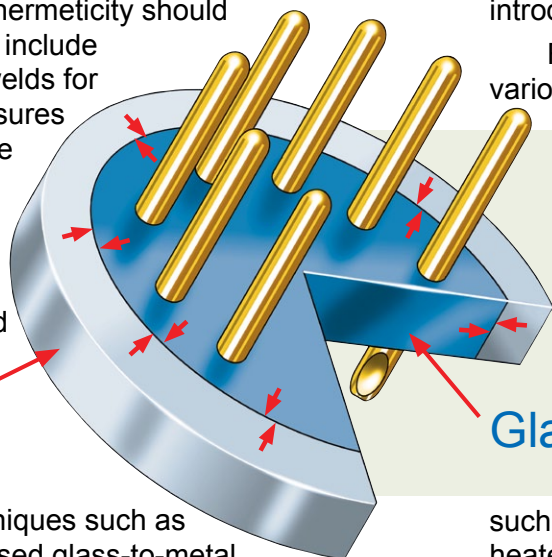

Metal Shell

Glass is an excellent insulator, bonds well to metallic surfaces and is extremely corrosion resistant. And because of its robust mechanical strength and resistance to radical changes in temperature and pressure, glass seals are extremely resistant to any cracking which may introduce leaks into the hermetic package.

Fused glass seals may be produced from various recipes of ground, non-crystalline solids

In Matched Seal hermetics, thermal expansion of the glass and metal materials are nearly the same. The stress in the glass is therefore relatively small—an important factor in the design of Micro-D hermetic connectors, due to varying degrees of stress on the glass caused by the rectangular shape.

Glass Insulator

with simple techniques such as epoxy potting, fused glass-to-metal seals are usually specified in high-reliability applications.

such as silicates, borates and phosphates. When heated to high temperature and then cooled, these materials fuse into an amorphous solid called glass.



In hermetic connector manufacturing, the glass material is introduced either as separate glass beads or as a pre-formed glass seal insulator tooled to precise dimensions. The glass must be exactly selected for each application according to its ability to form a strong bond with the chosen metal materials. Electrical properties, such as high withstanding voltage and dielectric strength are also considered as is thermal and shock stability.

Depending on the style of connector being produced (rectangular versus circular, for example) two distinct categories of glass-seal hermetics may be specified. These are known as Matched and Mismatched (or Compression) Seals.

In hermetic connector manufacturing, the glass material is introduced either as separate glass beads or as a pre-formed glass seal insulator tooled to precise dimensions. The glass must be exactly selected for each application according to its ability to form a strong bond with the metal materials.

In Matched Seal hermetics, the thermal expansion and contraction of the glass and metal materials are relatively close, usually within 10% of each other, resulting in a product in which the stress in the glass is relatively small.

Matched Seals are extremely important in glass hermetic connectors such as the Micro-D, since the rectangular shape of the connector shell can exert varying degrees of stress on the glass. At ambient temperatures, the glass is well wetted (bonded) to the metal shell and contacts, but under little or no pressure or stress. Matched Seals can withstand high thermal and mechanical shocks, and are generally easier to manufacture than Mismatched (Compression) Hermetic Seals.

Kovar, a combination of iron, nickel and cobalt, is the material of choice for Match Seal hermetic receptacles—both shells and contacts.

In Mismatched (Compression) Seals, the thermal expansion/contraction of the metal exceeds that of the glass. During cooling, the metal contracts into the already solidifying glass to form an extremely robust compression bond.

**Glass Insulator
Metal Shell**

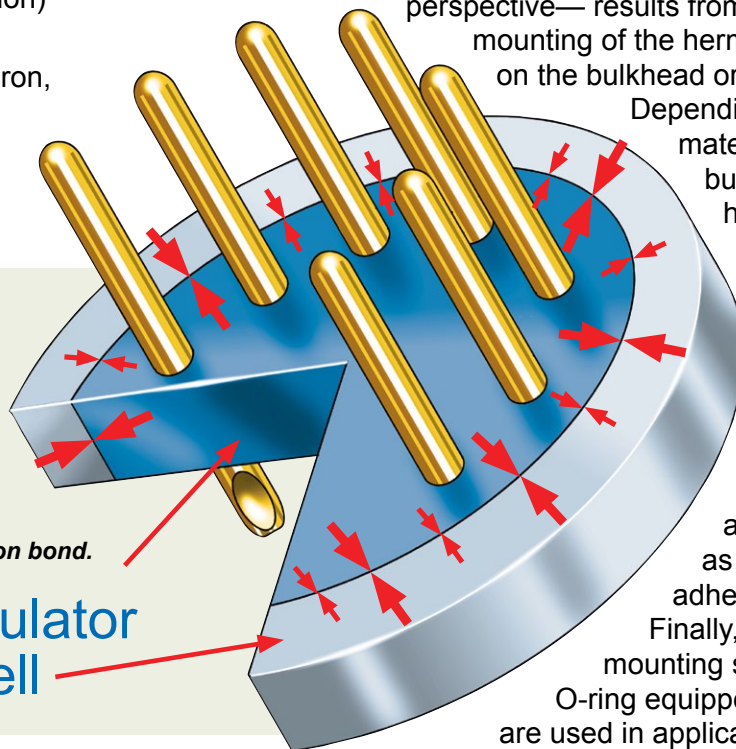

Kovar is a low-expansion metal with a coefficient of expansion rating matched to the glass material that forms the hermetic seal.

In Mismatched (Compression) Seals, the thermal expansion/contraction of the metal exceeds that of the glass. During the firing process, the metal materials, usually stainless steel, expand at a greater rate than the glass. During cooling, the metals contract back into the already solidifying glass to form an extremely robust compression bond. This type of seal is consequently the most frequently specified for connectors used in extreme, high-pressure applications since the seal produced is reliable to

pressures as high as 14,000 psi (1000 bars). The MIL-DTL-38999 connector falls into this category.

The total potential for leakage in a hermetic connector is the sum of any permeation which may occur via the metal materials themselves through cracks or open pores, and any leakage that may result from a defective seal. An additional source of leakage—uncontrolled

from the connector manufacturer's perspective—results from sub-standard mounting of the hermetic package on the bulkhead or enclosure.

Depending on the surface material of the bulkhead, hermetic

receptacles may be welded or soldered in place. Low temperature brazing is also possible in certain applications as is the use of adhesive sealants.

Finally, mechanical mounting seals such as O-ring equipped jam-nut mounts are used in applications where the cost or difficulty of welding or soldering is impractical.

Regardless of the choice of mounting technology, care must be given to ensure inadvertent leakage paths are not introduced. It is also important to note that vapor condensation in vacuum enclosures may be affected by the material makeup of component parts inside the enclosure. Materials such as silicones, adhesives, lubricants and Teflon insulation can all outgas water vapor, and so contribute to the total vapor pressure inside the enclosure. Vapor pressure directly impacts the condensation dew point of the protected environment.

Hermetic seals are qualified via various methodologies including helium testing and dye penetrant. The purpose of both types of tests is to detect and measure leakage under pressure. The dye penetrant method has the advantage of revealing the exact location of a leak, while Helium testing measures overall leakage within the hermetic device. In both types of tests, a pressure differential between the internal volume of the package and the external environment is created.

The resultant pressure gradient causes the helium or liquid dye to diffuse through the

connector shell, contacts and/or glass seals. Quantitative and qualitative measurements are then taken using appropriate sensing instruments. Glenair MIL-DTL-38999 qualified hermetic connectors are rated to 1×10^{-6} cc/second maximum helium leakage rate.

As with other connector classes, customers may specify the connector coupling style (threaded, bayonet, solder mount, etc.) pin or socket count and layout, contact termination type (solder cup, flat eyelet or PCB termination), conductive or non-conductive finish, polarization and so on.

EMI/EMP Filter Connectors

“Filtering” or suppression of electromagnetic noise within the connector package is reliably accomplished through the integration of capacitors and diodes into the connector to segregate interfering high-frequency or high voltage noise from the desired lower frequency signals. The capacitors strip off the interfering noise from the signal as it passes through the filter device. While various types of capacitor filters are available, perhaps the most widely applied is the Planar Array type.

Planar Arrays are extremely effective at filtering high-frequency interference. Planar Array designs utilize ceramic capacitor arrays and ferrite inductors which externally surround each contact, and may be supplied in a single monolithic block to fit into any connector

size or shape. Planar arrays may be fabricated with different capacitive values on individual pins for additional flexibility in achieving the desired level of EMC. Diodes are used to clamp the voltage below a certain value, thereby protecting the electronic circuitry. They are typically integrated into the connector using a small printed circuit board.

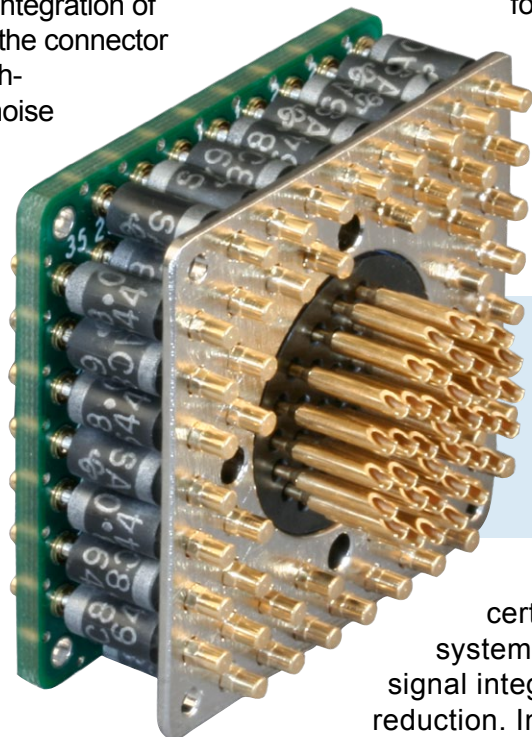

Ferrite elements and capacitors can be integrated into any connector package envelope.

Using filter technology has certain advantages to the electrical system engineer, including improved signal integrity as well as size and weight reduction. In addition, filters can be incorporated into an interconnect system late in the research and development process—for example after an unforeseen emission problem has been detected. In every filter application the signal levels

and frequency bands must be well understood in order to select the appropriate mode or type of filter technology.

For example, electronic equipment used by avionic systems typically spans the electromagnetic spectrum from a few kilohertz to several gigahertz. At the low end, Omega Navigation, which is used to fix aircraft position within a network of ground based transmitters, operates in the frequency range of 10 to 14 KHz. VHF Omnidirectional Range Finders (VOR) are radio beacons used in point-to-point navigation. They operate from 108 to 118 MHz. Glideslope Systems used during landings operate in the 328 to 335 MHz range. Distance-Measuring Equipment (DME), which gauges the space between the aircraft in the sky and ground-based transponders operate at frequencies of just over 1 GHz.

Clearly, potential EMI in the application environment described above covers a broad

range of frequencies. Filter modes and types are consequently specified according to the EMI frequency ranges which are the source of the actual signal degradation and the operating frequency of the affected device. Certain electrical circuit criteria are also germane to filter selection, including:

- Capacitance Value
- Working Voltage
- Surge Voltage
- Dielectric Withstand Voltage
- Insulation Resistance
- Transient Protection

Filter connectors appropriate for use in applications such as those referenced above are broadly identified as 'low-pass' filters (i.e. they let low frequency signals pass through and attenuate higher frequencies). The attenuation curve can

COMMON FILTER CONNECTOR TYPES

Glenair supplies filter connectors in the following electrical configurations: C, L-C, C-L, and Pi. The following general values may be used in type selection: Single element filter connectors sporting either a single capacitor or inductor yield an insertion loss characteristic of 20dB per decade, dual element filters (capacitor plus an inductor) 40dB per decade, and triple element filters 60dB per decade. Selection is based primarily on source and load impedances but may also be influenced by the level of attenuation required at various frequencies. Please consult the factory for assistance in evaluating insertion loss values.

C Filter

Single capacitor with low self inductance. This configuration is generally used to attenuate high frequency signals. The simple design allows high-frequency EMI to discharge to ground via the surrounding electromagnetic field.

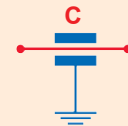

L-C or C-L Filter

Single capacitor combined with an inductive element. It is commonly used in a circuit with a both a low impedance source and a high impedance load or a low impedance load and a high impedance source. The inductive element should face the low impedance.

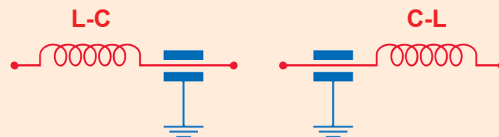

Pi Filter

Dual capacitors with a single inductive element positioned between them. The Pi filter provides exceptional high-frequency performance due to its sharper rolloff and is typically used when both source and load impedances are high.

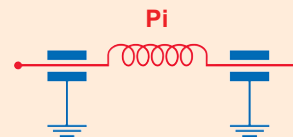

MIL-DTL-38999 Type Filter Connectors Overview



be shaped using different filter types (different configurations of capacitors and inductors). These types include: Pi Filter, L-C or C-L Filter, and C Filter. These filter connector types are characterized by their relative abilities to filter noise according to capacitance, voltage values and load impedances. The simplest design is the "C", which consists of a single capacitor inserted between the signal line and ground.

While most EMI filter connectors can be used in a working temperature environment from -55° to 125° C, selected designs are optimized for higher operating temperatures. Hermetic filter connectors provide the ultimate protection. The hermetic glass fused design protects the filter assembly while maintaining very low leakage rates.

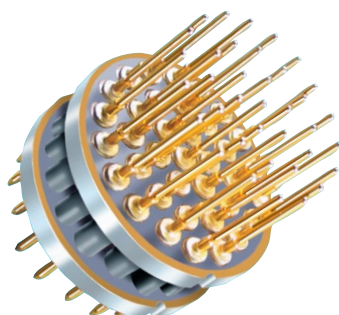

A multiway planar array filter device, assembled with its ferrite elements and connector contacts, ready for insertion into the connector shell. The flexible design allows for different capacitive values on individual pins as well as the integration of hybrid contacts such as optical termini.

Prior to shipping a filtered connector, Glenair offers extensive testing, qualification and burn-in options. Tests range from a simple capacitance (C), insulation resistance (IR), and dielectric withstanding voltage (DWV), to more elaborate options such as RF insertion loss, dissipation factor, Zener/TVS diode test, ground resistance, voltage conditioning and thermal shock.

The Glenair factory, provided with the system attenuation and frequency values, relevant electrical specifications, and connector configuration details, can design an effective filter device for every application (to get started, use the checklist found in the filter connector section of this catalog). In addition to the MIL-DTL-38999 type filter products cataloged in this book, Glenair is able to supply filter technology in virtually any connector package

including our own Series 80 "Mighty Mouse," Mil-C-24308, and MIL-DTL-83513 products. Hybrid electrical/optical filter connectors and hermetic filter designs are a specialty.

Multilayer Ceramic Planar Capacitor Arrays

Planar, multi-layer ceramic capacitive filters offer reduced size and improved performance compared to discrete discoidal or tubular capacitors. Planar array filter devices have the advantage, especially when compared to capacitive filters integrated at the circuit board level, of being bidirectionally effective at attenuating unwanted noise travelling into and out of equipment enclosures.

As mentioned, the planar array can be designed with different capacitive values on individual pins, and pin groupings, and can also be selectively equipped with surge protection diodes. The ability to accommodate such Transient Voltage Suppressions (TVS) diodes to protect against voltage spikes from transient sources such as EMP, lightning or Electrostatic Discharge (ESD) is an additional strength of the planar array design.

The planar array package can also easily accommodate ferrite elements to add inductance to the filter device. For these reasons and more, the planar array is the most common filter type specified in military aerospace and other high-performance applications. The planar array consists of multiple layers of ceramic dielectric separated by individual sheets of a ceramic tape material screen-printed with a pattern of metal electrodes. The exact configuration of the electrodes—their combined capacitance values, positions vis-a-vis individual contacts, selective grounding to the connector shell, etc.—determines the EMI attenuation properties of the filter device. After the layer-cake of dielectric materials and conductive elements is assembled, it is fired at high temperature to create a unified, monolithic structure. The planar array is fabricated such that the capacitor positions align exactly to the pin layout positions of the connector. When combined with inductive



MIL-DTL-38999 Type Filter Connectors Overview

A ferrite elements, TVS diodes or other special circuitry, the final assembly is ready for insertion into the connector shell. The incorporation of filter elements into a standard cylindrical or rectangular connector will necessarily increase the overall length of the package. The extra real estate is usually added to the inside-the-box (non-mating) side of the connector receptacle. Another approach is to attach a connector adapter, or go-between, outfitted with the filter device, to the connector plug. This approach has the advantage of not requiring any dimensional changes in box design or receptacle connector package.

Often, custom-configured planar arrays, with unique capacitive elements and values, are required to effectively address complex EMI problems such as might be encountered in an avionics bay or in the body of a missile. But many EMI problems can be satisfactorily addressed with standard catalog product designs. As critical EMI problems are often discovered late in the development process—perhaps only after equipment has been installed for use—it is critical that both standard catalog products as well as non-standard designs are delivered with the fastest possible turnaround. Glenair is committed to meeting the most aggressive delivery requirements for planar array type filter connectors.



Glenair can apply a broad range of custom shell configurations, filter values, TVS technologies—even hybrid fiber optic contacts—into any MIL-DTL-38999 type connector package, including bulkhead feed-thrus and connector savers.

Insertion Loss Evaluation

Insertion loss is an important specification to consider in the selection of filter connectors. Insertion loss is a measure of the degradation experienced by a signal when a device, such as a connector, is inserted into the transmission path.

When a filter element performs its job of stripping signal noise from a transmission line, it may attenuate a portion of the desired signal as well. Measured in decibels (dB), insertion loss should be minimized in sensitive electronic systems which may operate at extremely low current levels. Typically, some amount of insertion loss is considered acceptable to accomplish the necessary signal selectivity, since the signal can always be re-amplified post-filtering. However, in many applications, too large a loss may ultimately result in the unacceptable degradation of system performance.

The evaluation of insertion loss is performed over a specific frequency range—i.e., a spectrum that extends from one limiting frequency to another. The intent being to measure signal degradation for each filter type across the actual operating frequencies of the equipment under consideration. Note that each filter type may yield different (theoretical and actual) insertion loss values depending on the specific capacitance and inductance [pF] ratings of the filter elements. Effective EMI/EMP filtering is, therefore, a balance between the purposeful attenuation of signal noise and the unfortunate degradation of signal strength—both conditions directly attributable to the insertion of the filter device into the system.

Sensible EMC design should, as a consequence, always incorporate conventional grounding and shielding of interconnect cabling and equipment housings in anticipation of unexpected EMI problems. The tables on the opposite page explain predictable insertion loss [dB] for each filter type (C, L, and Pi), at the available capacitance ratings [pF] across a common frequency range [MHz].

MIL-DTL-38999 Type Filter Connectors Overview



C



INSERTION LOSS

Frequency	Insertion Loss, dB Minimum, 25°C						
	A	B	C	D	E	F	G
1 MHz	6	5	3	-	-	-	-
10 MHz	24	23	16	8	4	-	-
100 MHz	41	39	35	28	21	10	5
500 - 1000 MHz	50	49	46	41	34	23	17

CAPACITANCE

Filter Class	Capacitance
X	80000 – 120000 [pF]
Y	40000 – 60000 [pF]
Z	30000 – 45000 [pF]
A	19000 – 28000 [pF]
B	16000 – 22500 [pF]
C	9000 – 16500 [pF]
D	4000 – 6000 [pF]
E	1650 – 2500 [pF]
F	400 – 650 [pF]
G	200 – 300 [pF]

Pi



INSERTION LOSS

Frequency	Insertion Loss, dB Minimum, 25°C						
	A	B	C	D	E	F	G
1 MHz	10	8	5	1	-	-	-
10 MHz	40	35	25	14	8	2	0.8
100 MHz	62	60	57	50	40	15	13
500 - 1000 MHz	66	62	60	58	52	32	22

CAPACITANCE

Filter Class	Capacitance
X	1600000 – 240000 [pF]
Y	80000 – 120000 [pF]
Z	60000 – 90000 [pF]
A	38000 – 56000 [pF]
B	32000 – 45000 [pF]
C	18000 – 33000 [pF]
D	8000 – 12000 [pF]
E	3300 – 5000 [pF]
F	800 – 1300 [pF]
G	400 – 600 [pF]

APPLICATION NOTES

- Standard voltage rating is 500 V DWV.
- Insertion loss values quoted are for 50Ω impedance and no load condition.
- Classes X, Y and Z are 250 V DWV. Consult factory for additional information.
- Some shell configurations may require extra length for classes X, Y and Z.



Custom Options in Filtered Connectors

Glenair MIL-DTL-38999 type filter connector designs may be optimized for use in a wide range of application environments including avionic systems, down-hole drilling and logging devices, network-centric ground warfare systems, and missile and satellite/space applications. Common electrical customizations include unique capacitance values on individual lines, electrostatic discharge designs, transient voltage suppression diodes, grounded holes and feed-throughs, as well as the incorporation of customer-specified filter architectures including Pi, C, L-C, C-L and T configurations.

Non-standard packaging options in EMI/EMP filter connectors include:

- Hybrid Fiber Optic/Electrical Contacts
- Dual-Flange PCB Mount Designs
- Composite Thermoplastic Shell Materials
- Variable Length PCB Tails
- Piggy-Back Crimp Contacts
- EMI Grounding Fingers and Gaskets
- In-Line, Feed-Through, Plug and Other Shell Styles

EMP and Transient Voltage Suppression

Electromagnetic Pulse (EMP) refers to intense radio frequency pulses produced by nuclear explosions at high altitudes. Other names for this phenomenon are Nuclear EMP (NEMP), and High-Altitude EMP (HEMP). Like other forms of electromagnetic interference, EMP can have a destructive effect on sensitive electronic devices, if the EMP grounds to an unshielded cable and passes into the electronic device.

EMP hardened equipment is designed to protect vital communications at a time when unhardened devices are likely to fail. Thus it is standard for many military applications to proactively protect certain devices from EMP. This is accomplished, in part, by the integration of Transient Voltage Suppression technologies into the connectors that service the device.

Transient Voltage Suppression (TVS) technologies are designed to shunt voltage transients directly to ground before such surges can damage sensitive electronic equipment. Individual TVS diodes as well as diode modules may be incorporated directly into the filter connector package to provide optimal protection for either individual contacts or groups of contacts without significant increases in connector size or weight. Individual circuit protection diodes and diode modules are available for all connector types and are routinely stocked by Glenair to reduce lead-times. Individual diodes and modules may be screened and tested prior to assembly to ensure reliable performance. Field maintenance and repair of damaged diodes is also possible as both individual diodes and diode modules are easily removed from the connector package. RTCA DO-160 and other electrical performance standards now define acceptable benchmarks for withstanding electromagnetic pulse, lightning strike, or other induced voltage surges in high-reliability systems. Glenair designs all TVS equipped filter connectors to conform to the RTCA DO-160 standard.

Composite Connectors and Lightning Strike

Composite thermoplastic materials, such as the 30% glass filled polyetherimide (PEI) used in Glenair's MIL-DTL-38999 Series II Wall Mount Receptacle Connector have been tested for mechanical and electrical survivability to direct and indirect lightning strike. At issue is the ability of the composite connector shell to maintain its electrical continuity in the event of an intense voltage surge resulting from lightning strike.

In testing in accordance with MIL-STD-1344, items are subjected to waveform 1 and 5B using a high current generator. Items must remain functional without degradation of the unit's electrical performance, including filtering elements and TVS diodes and modules. Waveform 1 and 5B are applied starting at 3Ka increasing to 20Ka checking continuity measurements at set intervals. Waveform 1 is additionally subjected to an oscillatory wave starting at 30Ka and increasing in 10Ka steps until failure in continuity is measured.

While larger composite connector shell sizes (12 to 24) conform to MIL-STD-1344, smaller sizes (8 and 10) fail the test. Customers should select alternative materials, aluminum or stainless steel, when specifying small connector shell sizes in applications subject to lightning strike.



Glenair composite connectors and backshell are tested IAW MIL-STD-1344 lightning strike.

Soldering

Our filter connector engineers are frequently asked about any special handling procedures that are required when soldering PC Tail and Solder-cup contacts. At issue is the potential to damage filter elements due to the high heat of the soldering process. The short answer is that any trained and qualified operator can complete the operation without any special precautions. While it certainly can't hurt to take some basic precautions such as preheating the connector or utilizing a heat sink on individual contacts, our tests have revealed that, under normal conditions, the temperature of the ceramic filter array is not radically raised during solder termination of the contacts. Even in tests where we used a solder iron temperature of 350°C and an extremely long 'touch time' of 90 seconds, no adverse effects were observed. In fact, temperature at the ceramic remained well below 100°C at all times.

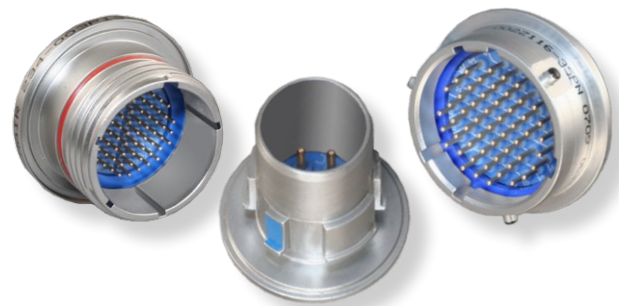

Hermetic Filter Connectors

Hermetic class EMI/EMP filter connectors are available throughout our complete range of MIL-DTL-38999 type filter connector products in both Pi and C from 400 pF to 56000 pF. Select either class H2 (stainless steel, electroless nickel), or class XM (composite, electroless nickel).

Hermetic connectors with EMI/EMP filtering are specified for applications as divergent as submarines, orbiting satellites, oil-patch logging equipment or medical devices that require both filtering elements and hermeticity. In addition to their EMI management function, the connectors are deployed to resist moisture ingress in



MIL-DTL-38999 Type Filter Connectors Overview

underground applications and to withstand pressure differentials in vacuum chambers, laboratory equipment and commercial and military aircraft. Hermetic filter connectors are constructed from a core component-set that includes the connector shell, the planar array filtering device, a vitreous glass insert and the necessary interfacial sealing.

Shells may be machined from stainless steel or Kovar®, an iron-nickel-cobalt alloy with a coefficient of expansion closely balanced to

the glass inserts. Contacts used in hermetic connectors must be fabricated from high-grade materials that can withstand high-heat, and bond effectively to the vitreous glass seal.

Glennair offers both standard hermetic/filter products compatible with standard MIL-DTL-38999 plugs as well as non-standard designs with unique filter values or voltage suppression technologies. Our goal is to always provide the fastest turnaround in the industry. Please consult the factory for unique packaging requirements.

Filter Module Elements

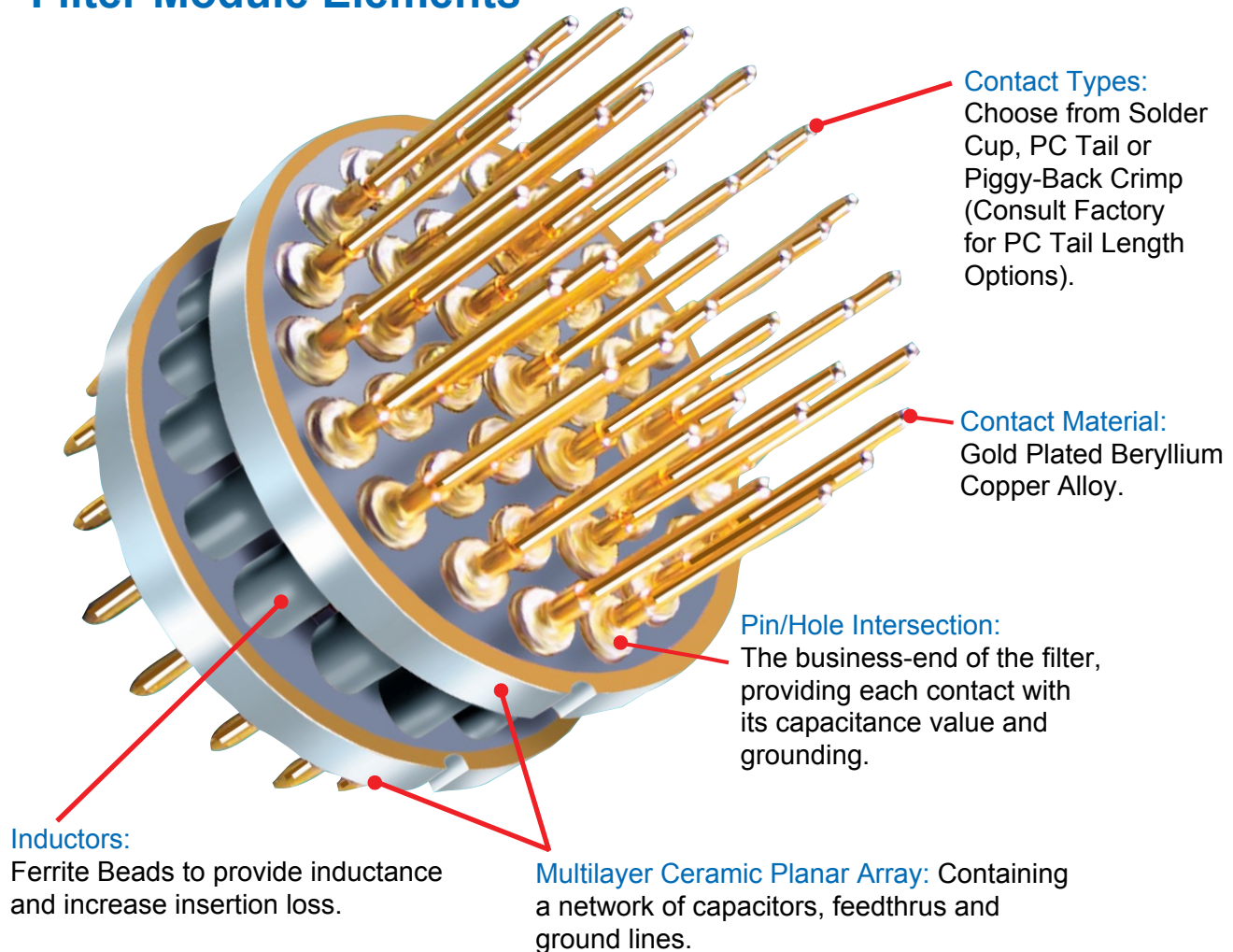

MIL-DTL-38999 Connectors for Space Flight

Nonmetallic materials such as rubber, plastic, adhesives and potting compounds can give off gasses when subjected to a vacuum or high heat. The space industry has adopted a standardized test procedure, ASTM E 595, to evaluate outgassing properties of products that contain polymer materials. In the ASTM test, material samples are heated to 125° C at a vacuum of 5 X 10⁻⁵ torr for 24 hours. The test sample is then weighed to calculate the Total Mass Loss (TML), which may not exceed 1.00% of the total initial mass. Likewise the quantity of outgassed matter is weighed to determine the Collected Volatile Condensable Material (CVCM), which may not exceed 0.10% of the original specimen mass.

For space grade applications, Glenair is able to offer both an 8 hour 400° bakeout process as well as a 24 hour 125° thermal vacuum outgassing process on connector products that must conform to NASA screening or other

outgassing standards. Our experience has been that the simpler bakeout process is more than adequate to meet the ASTM E 595 benchmark of 1.00% TML and 0.10% CVCM.

Glenair is well versed in supplying connector products that are optimized for use in space grade applications, and we supply MIL-DTL-38999 type compliant to EEE-INST-002, Table 2G, the recognized standard for space grade connectors. Section C2 “Connectors and Contacts” of NASA EEE-INST-002 provides guidelines for materials used in connectors for space flight applications: Aluminum is a preferred material for connector components, and electroless nickel is the preferred finish. Beryllium copper is a preferred material for contacts. 50 microinch minimum gold plating is the preferred contact finish. LCP is a preferred material for dielectric insulating materials. Specify “M” for aluminum shells with electroless nickel finish.

OUTGASSING PROPERTIES OF MATERIALS USED IN MIL-DTL-38999 CONNECTORS

Component	Material	TML %	TCVML %	Test Reference
Front and Rear Insulator	Liquid Crystal Polymer Vectra C130	0.03	0.0	NASA Test # GSC17478
Rear Grommet Interfacial Seal Peripheral Seal	Blended flourosilicone/silicone elastomer, 30% silicone per ZZ-R-765, 70% flourosilicone per MIL-R-25988	0.48	0.14	Glenair testing conducted at NuSil Technology 02/27/2001
Front-To-Rear Insulator Bonding Material	Eccobond 104 A/B	0.52	0.08	Emerson & Cuming Data Sheet
Insulator-to-Rubber Bonding Material	DC3145 RTV, per MIL-A-46146	1.74	0.90	NASA Test GSFC0191
Coupling Nut Retainer	Torlon® 4203L	1.88	0.01	Glenair Test at NuSil Technology 03-12-2003
Coupling Nut Epoxy	Hysol C9-4215	0.48	0.01	Glenair Test
White Epoxy Ink for Silk-screening	Markem 7224 White	0.49	0.03	NASA Test #GSC19899
Potting Compound, Solder Cup and PC Tail Connectors	Hysol C9-4215	0.48	0.01	Glenair Test
Potting Compound, Filter Receptacles	Stycast epoxy, 2850FT/Catalyst 11	0.29	0.02	Mfgr Data Sheet



MIL-DTL-38999 Connectors for Space Flight

1. Fluorosilicone rubber components such as O-rings and grommets exceed NASA outgassing limits.
2. NASA recommends outgassing processing to reduce outgassing to acceptable levels.
3. An inexpensive oven bakeout has better results than the more costly thermal vacuum outgassing. The higher temperature of the oven bakeout is more effective at removing volatile materials. However, both methods assure compliance with outgassing limits.
4. Glenair Mod 429 codes provide an easy ordering solution, whatever the outgassing option. Spacecraft designers generally avoid the use of ferromagnetic materials, which can become magnetized and can interfere with sensitive instruments. Aluminum shell connectors have a maximum permeability of 2 mu. Hermetic connector pins are iron alloy, a highly magnetic material.
5. Space programs sometimes need cryogenic connectors capable of withstanding temperatures as low as -270° C. D38999 connectors are rated to -65° C. Glenair does not have data to validate these connectors for cryogenic applications. EEE-INST-002 states "...experience has proven it is possible for (non-certified) connector types to be used successfully at cryogenic temperatures. It is recommended that connector samples should be subjected to five cycles of cryogenic temperature...(followed by examination for cracks and DWV)".

MIL-DTL-38999 CONNECTOR MATERIALS APPROVED FOR SPACE FLIGHT

Component	Material	Notes
Shells, Coupling Nuts, Jam Nuts	Aluminum alloy 6061 per ASTM B211, electroless nickel plated	Approved for Space Flight
Rigid Insulators	Glass-filled liquid crystal polymer (LCP) in accordance with MIL-M-24519, Type GLP-30F	Approved for Space Flight
Contact Retention Clip	Beryllium copper, heat-treated, unplated	Approved for Space Flight
Grommet, Peripheral Seal, Interfacial Seal, O-ring	Blended fluorosilicone/silicone elastomer, 30% silicone per ZZ-R-765, 70% fluorosilicone per MIL-R-25988	Requires outgassing processing
Hermetic Insert	Vitreous glass	Approved for Space Flight
Pin Contact	Beryllium copper alloy per ASTM B197, 50 microinches gold plated per ASTM B488 Type 3 Code C Class 1,27 over nickel plate per QQ-N-290 Class 2, 50-100 microinches	Approved for Space Flight
Pin Contact, Hermetic	Nickel-iron alloy per ASTM F30 (Alloy 52),50 microinches gold plated per ASTM B488 Type 3 Code C Class 1,27 over nickel plate per QQ-N-290 Class 2, 50-100 microinches	Ferromagnetic material.
Socket Contact	Beryllium copper alloy per ASTM B197, 50 microinches gold plated per ASTM B488 Type 3 Code C Class 1,27 over nickel plate per QQ-N-290 Class 2, 50-100 microinches.	Approved for Space Flight
Socket Contact Hood	Stainless steel, passivated per AMS-QQ-P-35	Approved for Space Flight
Adhesives	RTV and epoxies (see following table for outgassing info)	Requires outgassing processing
Potting Compound, PCB and Solder Cup Versions	Environmental and Hermetic Connectors: Stycast 2651/Catalyst 9 epoxy encapsulant. Filter Connectors: Stycast 2850FT/Catalyst 11 thermally conductive epoxy encapsulant.	Approved for Space Flight
Filter Element	Multilayer Ceramic Planar Array, ferrite inductors	Approved for Space Flight

MIL-DTL-38999 Connector Performance Specifications



Test	Performance Specifications																																																							
Dielectric Withstanding Voltage	<p>(meets MIL-C-38999, paragraph 3.14) Test voltage at sea level — 1300 Volts AC (rms). Wired, assembled, unmated connectors withstand the following:</p> <table border="1"> <tr> <td>550 VAC (rms) @ 50,000 ft.</td> </tr> <tr> <td>350 VAC (rms) @ 70,000 ft.</td> </tr> <tr> <td>200 VAC (rms) @ 100,000 ft.</td> </tr> </table>	550 VAC (rms) @ 50,000 ft.	350 VAC (rms) @ 70,000 ft.	200 VAC (rms) @ 100,000 ft.																																																				
550 VAC (rms) @ 50,000 ft.																																																								
350 VAC (rms) @ 70,000 ft.																																																								
200 VAC (rms) @ 100,000 ft.																																																								
Insulation Resistance	<p>(meets MIL-C-38999, paragraph 3.13) Unmated connectors shall be tested as specified in test method EIA-364-21 5000 megohms min. at 25° C</p>																																																							
Supported Wire Size	<p>(meets MIL-DTL-38999, paragraph 3.4.3.1)</p> <table border="1"> <thead> <tr> <th>Contact Size</th> <th>Wire Gauge</th> </tr> </thead> <tbody> <tr> <td>22D</td> <td>#22 - #28</td> </tr> <tr> <td>20</td> <td>#20 - #24</td> </tr> <tr> <td>16</td> <td>#16 - #20</td> </tr> <tr> <td>12</td> <td>#12 - #14</td> </tr> <tr> <td>10</td> <td>#10 - #12</td> </tr> </tbody> </table>	Contact Size	Wire Gauge	22D	#22 - #28	20	#20 - #24	16	#16 - #20	12	#12 - #14	10	#10 - #12																																											
Contact Size	Wire Gauge																																																							
22D	#22 - #28																																																							
20	#20 - #24																																																							
16	#16 - #20																																																							
12	#12 - #14																																																							
10	#10 - #12																																																							
EMI Shielding	<p>(meets MIL-DTL-38999, paragraph 3.31) Effective over a range of 100 MHz to 10 GHz with a minimum 50dB effectiveness at 10GHz, in accordance with test method EIA-364-10</p> <table border="1"> <thead> <tr> <th rowspan="2">Frequency MHz</th> <th colspan="3">Attenuation Minimum dB</th> </tr> <tr> <th>Series I</th> <th>Series II</th> <th>Series III and IV</th> </tr> </thead> <tbody> <tr> <td>100</td> <td>90</td> <td>65</td> <td>90</td> </tr> <tr> <td>200</td> <td>88</td> <td>60</td> <td>88</td> </tr> <tr> <td>300</td> <td>88</td> <td>55</td> <td>88</td> </tr> <tr> <td>400</td> <td>87</td> <td>55</td> <td>87</td> </tr> <tr> <td>800</td> <td>85</td> <td>45</td> <td>85</td> </tr> <tr> <td>1,000</td> <td>85</td> <td>45</td> <td>85</td> </tr> <tr> <td>1,500</td> <td>69</td> <td>—</td> <td>76</td> </tr> <tr> <td>2,000</td> <td>65</td> <td>—</td> <td>70</td> </tr> <tr> <td>3,000</td> <td>61</td> <td>—</td> <td>69</td> </tr> <tr> <td>4,000</td> <td>58</td> <td>—</td> <td>68</td> </tr> <tr> <td>6,000</td> <td>55</td> <td>—</td> <td>66</td> </tr> <tr> <td>10,000</td> <td>50</td> <td>—</td> <td>65</td> </tr> </tbody> </table>	Frequency MHz	Attenuation Minimum dB			Series I	Series II	Series III and IV	100	90	65	90	200	88	60	88	300	88	55	88	400	87	55	87	800	85	45	85	1,000	85	45	85	1,500	69	—	76	2,000	65	—	70	3,000	61	—	69	4,000	58	—	68	6,000	55	—	66	10,000	50	—	65
Frequency MHz	Attenuation Minimum dB																																																							
	Series I	Series II	Series III and IV																																																					
100	90	65	90																																																					
200	88	60	88																																																					
300	88	55	88																																																					
400	87	55	87																																																					
800	85	45	85																																																					
1,000	85	45	85																																																					
1,500	69	—	76																																																					
2,000	65	—	70																																																					
3,000	61	—	69																																																					
4,000	58	—	68																																																					
6,000	55	—	66																																																					
10,000	50	—	65																																																					
Thermal Shock	<p>(meets MIL-C-38999, paragraph 3.7) After cycling the connector between -65° C and +175° C, it will meet all applicable electrical and mechanical requirements.</p>																																																							



MIL-DTL-38999 Connector Performance Specifications

A

Test	Performance Specifications																										
Physical Shock	<i>(meets MIL-C-38999, paragraph 3.27)</i> No loosening of parts, cracking or other deleterious results hindering further part operation after 300 G's in each of 3 mutually perpendicular planes.																										
Fluid Compatibility	<i>(meets MIL-DTL-38999, paragraph 3.33)</i> Designed to function in all fluids encountered in any modern military or aerospace environment																										
Fluid Immersion	<i>(meets MIL-DTL-38999, paragraph 3.31)</i>																										
	<table border="1"> <thead> <tr> <th>Frequency (MHz)</th> <th>50 Leakage Attenuation Minimum (dB)</th> </tr> </thead> <tbody> <tr><td>100</td><td>90</td></tr> <tr><td>200</td><td>88</td></tr> <tr><td>300</td><td>87</td></tr> <tr><td>400</td><td>85</td></tr> <tr><td>800</td><td>85</td></tr> <tr><td>1,000</td><td>85</td></tr> <tr><td>1,500</td><td>69</td></tr> <tr><td>2,000</td><td>65</td></tr> <tr><td>3,000</td><td>61</td></tr> <tr><td>4,000</td><td>58</td></tr> <tr><td>6,000</td><td>55</td></tr> <tr><td>10,000</td><td>50</td></tr> </tbody> </table>	Frequency (MHz)	50 Leakage Attenuation Minimum (dB)	100	90	200	88	300	87	400	85	800	85	1,000	85	1,500	69	2,000	65	3,000	61	4,000	58	6,000	55	10,000	50
	Frequency (MHz)	50 Leakage Attenuation Minimum (dB)																									
	100	90																									
	200	88																									
	300	87																									
	400	85																									
	800	85																									
	1,000	85																									
	1,500	69																									
	2,000	65																									
	3,000	61																									
	4,000	58																									
6,000	55																										
10,000	50																										
High Impact Shock	<i>(meets MIL-C-38999, paragraph 3.27)</i> Mated connectors, wired with MIL-C-915/60 or /63 cable and equipped with straight environmentally sealed backshells, withstand high impact shock per MIL-S-901.																										
Vibration	<i>(meets MIL-C-38999, paragraph 3.26)</i> There shall be no electrical discontinuity and there shall be no disengagement of the mated connectors, backing off of the coupling mechanism, evidence of cracking, breaking, or loosening of parts.																										
Fungus	<i>(meets MIL-C-38999, paragraph 4.2.2)</i> Materials used in the construction of these connectors shall be fungus inert per certification of method 508.4 of MIL-STD-810																										
Corrosion	<i>(meets MIL-C-38999, paragraph 3.16)</i> When tested in accordance with EIA-364-26, meets appropriate electrical and mechanical requirements and shows no exposure of base metal after 500 hours of salt spray																										
Mating / Unmating Forces	<i>(meets MIL-C-38999, paragraph 3.10)</i> The coupling torque for mating and unmating of the counterpart connectors and protective covers shall meet the requirements of the table shown below.																										

MIL-DTL-38999 Connector Performance Specifications



Test	Performance Specifications																																																																																																		
Durability	(meets MIL-C-38999, paragraph 3.11) No electrical or mechanical defects after 500 cycles of engagement and disengagement																																																																																																		
Insert Retention	(meets MIL-C-38999, paragraph 3.15) Unmated connectors shall retain their inserts in their proper location in the shell and there shall be no evidence of cracking, breaking, separation from the shell, or loosening of parts.																																																																																																		
Contact Retention	(meets MIL-C-38999, paragraph 3.23) The axial displacement of the contact shall not exceed .012 inch (0.30 mm). No damage to contacts or inserts shall result.																																																																																																		
Coupling Pin Strength	(meets MIL-C-38999, paragraph 3.20) Applicable to series I and II only Bayonet coupling pins shall withstand a load of 50 +5, -0 pounds without displacement or perceptible loosening of coupling pins.																																																																																																		
Contact Engagement and Disengagement Forces	(meets MIL-C-38999, paragraph 3.16) Applicable to hermetic connectors with sockets only Contact engagement and separating forces shall be within the limits specified in SAE-AS39029 .																																																																																																		
Resistance to Probe Damage	(meets MIL-C-38999, paragraph 3.42) Applicable to hermetic connectors with sockets only Contacts shall withstand the bending moment and depth of test probe insertion without evidence of damage that would interfere with the mechanical or electrical performance.																																																																																																		
EMI Ground Spring Forces	(meets MIL-C-38999, paragraph 3.30) The forces necessary to engage and separate EMI plugs with receptacle shells shall be within the values specified in the table shown below: <table border="1" data-bbox="440 1318 1487 1703"> <thead> <tr> <th rowspan="2">Shell size</th> <th colspan="4">Axial force for Series I, II, and III</th> <th colspan="4">Axial force for Series IV</th> </tr> <tr> <th>Maximum Pounds</th> <th>Minimum Newtons</th> <th>Maximum Pounds</th> <th>Minimum Newton</th> <th>Pounds</th> <th>Newtons</th> <th>Pounds</th> <th>Newtons</th> </tr> </thead> <tbody> <tr> <td>8/9</td> <td>25</td> <td>111</td> <td>0.5</td> <td>2</td> <td>-</td> <td>-</td> <td>-</td> <td>-</td> </tr> <tr> <td>10/11</td> <td>25</td> <td>111</td> <td>0.5</td> <td>2</td> <td>5</td> <td>22.3</td> <td>0.3</td> <td>1.3</td> </tr> <tr> <td>12/13</td> <td>30</td> <td>133</td> <td>0.5</td> <td>2</td> <td>5</td> <td>22.3</td> <td>0.3</td> <td>1.3</td> </tr> <tr> <td>14/15</td> <td>30</td> <td>133</td> <td>0.5</td> <td>2</td> <td>6</td> <td>26.7</td> <td>0.4</td> <td>1.8</td> </tr> <tr> <td>16/17</td> <td>35</td> <td>156</td> <td>0.5</td> <td>2</td> <td>7</td> <td>31.1</td> <td>0.4</td> <td>1.8</td> </tr> <tr> <td>18/19</td> <td>35</td> <td>156</td> <td>0.5</td> <td>2</td> <td>8</td> <td>35.6</td> <td>0.5</td> <td>2.2</td> </tr> <tr> <td>20/21</td> <td>35</td> <td>156</td> <td>0.5</td> <td>2</td> <td>9</td> <td>40</td> <td>0.5</td> <td>2.2</td> </tr> <tr> <td>22/23</td> <td>35</td> <td>156</td> <td>0.5</td> <td>2</td> <td>10</td> <td>44.5</td> <td>0.5</td> <td>2.2</td> </tr> <tr> <td>24/25</td> <td>35</td> <td>156</td> <td>0.5</td> <td>2</td> <td>10</td> <td>44.5</td> <td>0.5</td> <td>2.2</td> </tr> </tbody> </table>	Shell size	Axial force for Series I, II, and III				Axial force for Series IV				Maximum Pounds	Minimum Newtons	Maximum Pounds	Minimum Newton	Pounds	Newtons	Pounds	Newtons	8/9	25	111	0.5	2	-	-	-	-	10/11	25	111	0.5	2	5	22.3	0.3	1.3	12/13	30	133	0.5	2	5	22.3	0.3	1.3	14/15	30	133	0.5	2	6	26.7	0.4	1.8	16/17	35	156	0.5	2	7	31.1	0.4	1.8	18/19	35	156	0.5	2	8	35.6	0.5	2.2	20/21	35	156	0.5	2	9	40	0.5	2.2	22/23	35	156	0.5	2	10	44.5	0.5	2.2	24/25	35	156	0.5	2	10	44.5	0.5	2.2
Shell size	Axial force for Series I, II, and III				Axial force for Series IV																																																																																														
	Maximum Pounds	Minimum Newtons	Maximum Pounds	Minimum Newton	Pounds	Newtons	Pounds	Newtons																																																																																											
8/9	25	111	0.5	2	-	-	-	-																																																																																											
10/11	25	111	0.5	2	5	22.3	0.3	1.3																																																																																											
12/13	30	133	0.5	2	5	22.3	0.3	1.3																																																																																											
14/15	30	133	0.5	2	6	26.7	0.4	1.8																																																																																											
16/17	35	156	0.5	2	7	31.1	0.4	1.8																																																																																											
18/19	35	156	0.5	2	8	35.6	0.5	2.2																																																																																											
20/21	35	156	0.5	2	9	40	0.5	2.2																																																																																											
22/23	35	156	0.5	2	10	44.5	0.5	2.2																																																																																											
24/25	35	156	0.5	2	10	44.5	0.5	2.2																																																																																											



MIL-DTL-38999 Contact Performance Specifications

A

Test	Performance Specifications					
Current Rating	<i>(meets MIL-C-39029, paragraph 1.3.1)</i>					
	Contact Size	Maximum Amps				
		<i>Crimp</i>	<i>Hermetic</i>			
	22D	5	3			
	20	7.5	5			
	16	13	10			
Contact Millivolt Drop	<i>(meets MIL-C-38999, paragraph 3.17)</i>					
	Contacts in the mated condition shall meet the contact resistance requirements of the table shown below. Appropriate compensation may be made for resistance in the measured value which is due to an additional length of wire included in the measurement.					
	Contact Size	Maximum Millivolt Drop				
		<i>Crimp</i>	<i>Hermetic</i>			
	22D	73	85			
	20	55	60			
Contact Resistance at 25° C	<i>(meets MIL-C-38999, paragraph 3.17)</i>					
	Contacts in the mated condition shall meet the contact resistance requirements of the table shown below. Appropriate compensation may be made for resistance in the measured value which is due to an additional length of wire included in the measurement.					
	Class	Contact Size	Wire Size	Test Amperes	Millivolt Drop Maximum	
					Initial	After Conditioning
	H, N and Y	12	12	17	85	100
		16	16	10	85	100
20		20	5	60	75	
22D		22	3	85	95	

MIL-DTL-38999 CONTACT MATERIALS AND SPECIFICATIONS

Component	Material	Notes
Pin Contact	Beryllium copper alloy per ASTM B197, 50 microinches gold plated per ASTM B488 Type 3 Code C Class 1,27 over nickel plate per QQ-N-290 Class 2, 50-100 microinches	Approved for Space Flight
Pin Contact, Hermetic	Nickel-iron alloy per ASTM F30 (Alloy 52), 50 microinches gold plated per ASTM B488 Type 3 Code C Class 1,27 over nickel plate per QQ-N-290 Class 2, 50-100 microinches	Ferromagnetic material.
Socket Contact	Beryllium copper alloy per ASTM B197, 50 microinches gold plated per ASTM B488 Type 3 Code C Class 1,27 over nickel plate per QQ-N-290 Class 2, 50-100 microinches.	Approved for Space Flight
Socket Contact Hood	Stainless steel, passivated per AMS-QQ-P-35	Approved for Space Flight

RoHS Compliant Plating Options for MIL-DTL-38999 Connectors and Accessories



The 30 May 2008 MIL-DTL-38999 Rev L specification provides guidance on the use of alternative parts with less hazardous or nonhazardous materials. In this regard, the specification provides for a number of alternative plating materials. Users are directed to select the least hazardous plating material that meets the form, fit and function requirements of their application.

Glenair would like to draw our customer's attention to two finish materials that conform to this guidance:

T – Environment resisting Nickel fluorocarbon polymer. Conductive Nickel with fluorocarbon polymer additives over a suitable underplate to withstand 500 hours of dynamic salt spray testing.

Z – Environment resisting Zinc nickel (conductive) in accordance with ASTM B841 over a suitable underplate to withstand 500 hours of dynamic salt spray testing.

These two plating solutions are both cadmium and hexavalent chromium free, which allows them to be defined as RoHS compliant parts. Here are some additional details on these two surface finishes:

Temperature Resistance: Class T - Nickel fluorocarbon polymer (Glenair's MT Ni-PTFE **1,000 Hour Grey™** finish) is rated from -65°C to +175°C. The Class Z - Zinc Nickel (Glenair's ZN finish) is rated from -65°C to +175°C.

Plating adhesion: When tested as specified in 4.5.5, there shall be no blistering, peeling, flaking or separation of plating or other damage detrimental to the operation of the connector.

Dissimilar metals and compatible couples: Both finishes satisfy prohibitions against dissimilar metal coupling as specified in MIL-STD-889.

Shell-to-shell conductivity (millivolts): Both finishes are rated at 2.5 millivolt drop potential.



Glenair Nickel-PTFE 1,000 Hour Grey™ RoHS Compliant Plating is Now Available for All Environmental Class D38999 Connector Products.

Sulfur Dioxide Resistance: Both finishes pass the requisite 336 hours resistance to Sulfur Dioxide.

Glenair is pleased to make these environmentally-friendly plating finishes available to our MIL-DTL-38999 customers. Both surface finishes provide outstanding mechanical, electrical and environmental performance and many be applied to both aluminum alloy, stainless steel as well as composite thermoplastic versions of our products, including connectors and accessories. Glenair is a leader in the advancement of alternative plating solutions and offers as broad a selection as any manufacturer in our industry.

MIL-DTL-38999 Series I, II, III and IV Qualified Hermetic Connectors

SECTION B TABLE OF CONTENTS

GLENAIR MIL-DTL-38999 SERIES I, II, III AND IV QUALIFIED HERMETIC CONNECTORS:

MIL-DTL-38999 QPL'd Hermetic Connector Product Features.....	B-1
MIL-DTL-38999 Series I, II, III and IV Hermetic Class Insert Arrangements.....	B-2
MIL-DTL-38999 Series I, II, III and IV Hermetic Class Layouts and Pin Counts.....	B-4
MIL-DTL-38999 Hermetic Class Material Specifications and Finishes.....	B-5
MS27469 Wall Mount Hermetic Receptacle, Series I	B-6
MS27470 Jam Nut Mount Hermetic Receptacle, Series I	B-8
MS27471 Solder Mount Hermetic Receptacle, Series I	B-10
MS27475 Wall Mount Hermetic Receptacle, Series II	B-12
MS27476 Box Mount Hermetic Receptacle, Series II	B-14
MS27477 Jam-Nut Mount Hermetic Receptacle, Series II	B-16
MS27478 Solder Mount Hermetic Receptacle, Series II	B-18
D38999/21 Box Mount Hermetic Receptacle, Series III	B-20
D38999/23 Jam Nut Mount Hermetic Receptacle, Series III	B-22
D38999/25 Solder Mount Hermetic Receptacle, Series III	B-24
D38999/27 Weld Mount Hermetic Receptacle, Series III	B-26
D38999/41 Box Mount Hermetic Receptacle, Series IV	B-28
D38999/43 Jam Nut Mount Hermetic Receptacle, Series IV	B-30
D38999/45 Solder Mount Hermetic Receptacle, Series IV	B-32
D38999/48 Weld Mount Hermetic Receptacle, Series IV	B-34
257-333 Jam Nut Hermetic Receptacle with Crimp Removable Socket Contacts, Series III.....	B-36

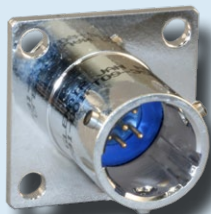

Series I

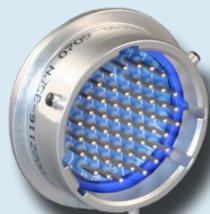

Series II

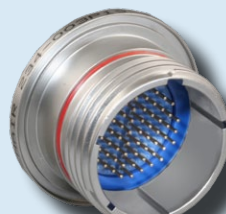

Series III



Series IV



The Full Range of MIL-DTL-38999 Series I, II, III and IV Hermetic Receptacles—*Plus Glenair Commercial Equivalents*

Product Applications

The MIL-DTL-38999 Series I, II, III and IV family of hermetic connectors are ideal for high-pressure/low-leakage applications in air, sea and space environments. Glenair is on the Qualified Product List (QPL) for all configurations of MIL-DTL-38999 Series I through IV pin and socket hermetic connectors. We also offer our D38999 type commercial part numbers for applications that do not require MS qualified products.

Materials

Glenair MIL-DTL-38999 Series I, II, III and IV Hermetic Connectors are made of stainless (CRES) or carbon steel (CRS), with glass

Nickel-iron alloy 52 gold-plated contacts, available in sizes 8, 10, 12, 16, 20 and 22D, depending on the layout chosen, offer a wide selection of insert arrangement options. Solder cup, feed through (PCB Flexprint) and eyelet contact styles are also available.

Same-Day Inventory

Because Glenair makes all its hermetic connectors in-house, including the machining of shells, molding of interfacial seals and firing of hermetic components, we can offer you outstanding availability on stock products and fast turnaround on special orders.

Same-Day Delivery on Most Common Shell Styles and Layouts

Full Range of D38999 Series I thru IV Pin and Socket Insert Arrangements

DSCC Approved QPL Hermetics

1 x 10⁻⁶ cc/Helium per Second Leakage Rate

CRES and CRS Shells with Vitreous Glass Sealing with All Standard Material Options

Jam Nut, Solder Mount, Wall Mount and Box Mount Options



insulators fused to the connector shell, and contacts meeting a leak rate of 1 X 10⁻⁶ cc/Helium per second. Maximum design flexibility is built into the Series I, II, III and IV Military Standard Hermetic Connectors – with a minimum of 2 to a maximum of 128 circuits per connector in a wide variety of contact arrangements IAW MIL-STD-1560. Fluorosilicone rubber interfacial and peripheral seals ensure positive sealing with plug connectors.

Catalog contents—including part numbers, materials and dimensions—are accurate to the best of our ability when we go to print. Even so, customers are advised to consult the factory for the latest specifications, particularly to confirm critical dimensions such as connector lengths, threads, and so on. When errors or mistakes are brought to our attention, corrected content is posted immediately to www.glenair.com.



MIL-DTL-38999 Series I, II, III, and IV Hermetic Class Connectors Insert Arrangements (IAW MIL-STD-1560)

B

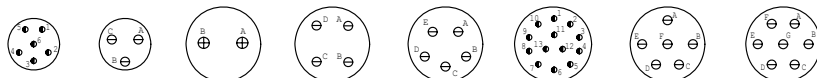

Series I	9-35	9-98	11-2	11-4	11-5	11-35	11-98	11-99
Series II	8-35	8-98	10-2	10-4	10-5	10-35	10-98	10-99
Series III	A35	A98	B2	B4	B5	B35	B98	B99
Series IV	---	---	---	---	B5	B35	B98	B99

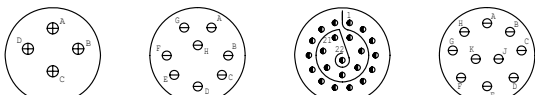

Series I	13-4	13-8	13-35	13-98
Series II	12-4	12-8	12-35	12-98
Series III	C4	C8	C35	C98
Series IV	C4	---	C35	C98

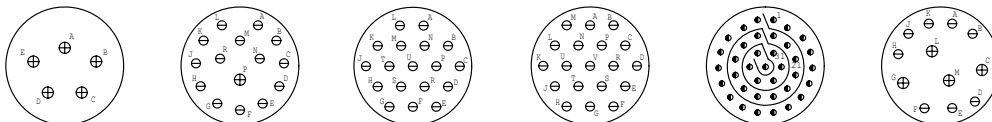

Series I	15-5	15-15	15-18	15-19	15-35	15-97
Series II	14-5	14-15	14-18	14-19	14-35	14-97
Series III	D5	D15	D18	D19	D35	D97
Series IV	D5	---	D18	D19	D35	D97

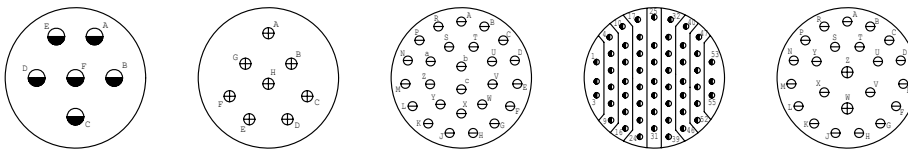

Series I	17-6	17-8	17-26	17-35	17-99
Series II	16-6	16-8	16-26	16-35	16-99
Series III	E6	E8	E26	E35	E99
Series IV	E6	E8	E26	E35	---

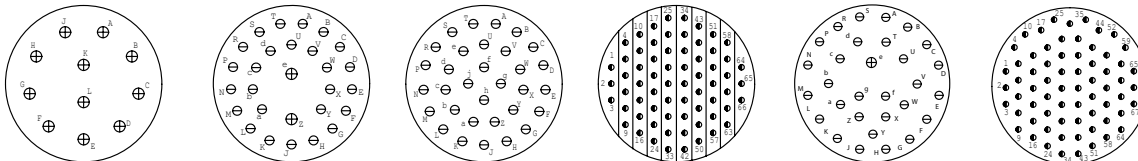

Series I	19-11	19-28	19-32	19-35	19-30	19-45
Series II	18-11	18-28	18-32	18-35	18-30	18-45
Series III	F11	F28	F32	F35	F30	F45
Series IV	F11	---	F32	F35	---	---



MIL-DTL-38999 Series I, II, III, and IV Hermetic Class Connectors Insert Arrangements (IAW MIL-STD-1560)



D38999 QPL
Hermetics

B

Series I 21-11	21-16	21-35	21-41	
Series II 20-11	20-16	20-35	20-41	
Series III, IV G11, G11	G16, G16	G35, G35	G41, G41	
Series I 21-24	21-25	21-27	21-39	
Series II 20-24	20-25	20-27	20-39	
Series III, IV G24, G24	G25, ---	G27, ---	G39, ---	
Series I 23-21	23-35	23-53	23-55	23-32
Series II 22-21	22-35	22-53	22-55	22-32
Series III, IV H21, H21	H35, H35	H53, ---	H55, H55	H32, ---
Series I 23-34	23-36	23-97	23-99	
Series II 22-34	22-36	22-97	22-99	
Series III, IV H34, ---	H36, ---	H97, ---	H99, ---	
Series I 25-29	25-35	25-61	25-4	
Series II 24-29	24-35	24-61	24-4	
Series III, IV J29, J29	J35, J35	J61, J61	J4, J4	
Series I 25-43	25-19	25-24	J-11 (Series IV Only)	
Series II 24-43	24-19	24-24		
Series III, IV J43, J43	J19, J19	J24, J24		

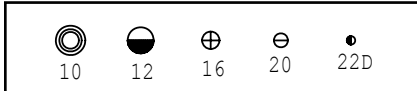



MIL-DTL-38999 Series I, II, III, and IV Hermetic Class Connectors Layouts and Pin Counts

B

Shell Size and Insert Arrangements			Number of Pins			
MS Series I	MS Series II	D38999 Series III	22D	20	16	12
9-35	8-35	A35	6			
9-98	8-98	A98		3		
11-2	10-2	B2			2	
11-4	10-4	B4		4		
11-5	10-5	B5		5		
11-35	10-35	B35	13			
11-98	10-98	B98		6		
11-99	10-99	B99		7		
13-4	12-4	C4			4	
13-8	12-8	C8		8		
13-35	12-35	C35	22			
13-98	12-98	C98		10		
15-5	14-5	D5			5	
15-15	14-15	D15		14	1	
15-18	14-18	D18		18		
15-19	14-19	D19		19		
15-35	14-35	D35	37			
15-97	14-97	D97		8	4	
17-6	16-6	E6				6
17-8	16-8	E8			8	
17-26	16-26	E26		26		
17-35	16-35	E35	55			
17-99	16-99	E99		21	2	
19-11	18-11	F11			11	
19-28	18-28	F28		26	2	
19-30	18-30	F30		29	1	
19-32	18-32	F32		32		
19-35	18-35	F35	66			
19-45	18-45	F45	67			
21-11	20-11	G11				11
21-16	20-16	G16			16	
21-24	20-24	G24		24		
21-25	20-25	G25		25		
21-27	20-27	G27		27		
21-35	20-35	G35	79			
21-39	20-39	G39		37	2	
21-41	20-41	G41		41		
23-21	22-21	H21			21	
23-32	22-32	H32		32		
23-34	22-34	H34		34		
23-35	22-35	H35	100			
23-36	22-36	H36		36		
23-53	22-53	H53		53		
23-55	22-55	H55		55		
23-97	22-97	H97			16	
23-99	22-99	H99			11	
25-4	24-4	J4		48	8	
25-19	24-19	J19				19
25-24	24-24	J24			12	12
25-29	24-29	J29			29	
25-35	24-35	J35	128			
25-37	N/A	J37	37		37	16
25-43	24-43	J43		23	20	
25-61	24-61	J61		61		

Shell Size / Insert Arrangements		Number of Pins				
D38999 Series IV	22D	20	16	12	10	
B5		5				
B35	13					
B98		6				
B99		7				
C4			4			
C35	22					
C98		10				
D5			5			
D18		18				
D19	37	19				
D35						
D97		8	4			
E6				6		
E8			8			
E26		26				
E35	55					
F11			11			
F32		32				
F35	66					
G11				11		
G16			16			
G35	79					
G41		41				
H21			21			
H35	100					
H55		55				
J4		48	8			
J11		2			9	
J19				19		
J24			12	12		
J29			29			
J35	128					
J43		23	20			
J61		61				
J37			37			

MIL-DTL-38999 Series I, II, III and IV Hermetic Class Connectors Material Specifications



D38999 QPL
Hermetics

B

TABLE I: HERMETIC CLASS MATERIALS

Shell, Barrel Coupling and Jam Nut (Hermetic)	Stainless steel per AMS-QQ-S-763
Shell, Barrel, Coupling Nut and Jam Nut (Hermetic)	Carbon Steel per ASTM-B545 or ASTM-B339
Front and Rear Insulators	Glass-filled liquid crystal polymer (LCP) in accordance with MIL-M-24519, Type GLP-30F
Grommet, Peripheral Seal and Interfacial Seal	Blended elastomer, 30% silicone per ZZ-R-765, 70% fluorosilicone per MIL-R-25988
Hermetic Insert	Vitreous glass
Pin Contact (Hermetic)	Nickel-iron alloy per ASTM F30 (Alloy 52), 50 microinches gold plated per ASTM B488 Type 3 Code C Class 1, 27 over nickel plate per QQ-N-290 Class 2, 50-100 microinches
Socket Contact (Hermetic)	Copper Alloy, Gold Plated IAW ASTM B488, Type 3, Code C
Adhesives	Silicone and epoxy
Potting Compound, PCB and Solder Cup Versions	Environmental and Hermetic Connectors: High-strength epoxy, Hysol EE4215. Filter Connectors: Stycast 2850FT/Catalyst 11 thermally conductive epoxy encapsulant.

TABLE II: HERMETIC CLASS FINISHES

Plating Code	Material	Finish	Specification
Glenair Commercial Equivalent Plating Codes			
Z1	Stainless Steel	Passivate	AMS-QQ-P-35
FT	Carbon Steel	Fused Tin Plate	ASTM-B545 or ASTM-B339
ZL	Stainless Steel	Electrodeposited Nickel	SAE-AMS-QQ-N-290, Class 2
MIL-DTL-38999 Plating Codes			
D	Carbon Steel	Fused Tin Plate	ASTM-B545 or ASTM-B339
E	Stainless Steel	Passivate	AMS-QQ-P-35
N	Stainless Steel	Electrodeposited Nickel	SAE-AMS-QQ-N-290, Class 2

How To Order: MS

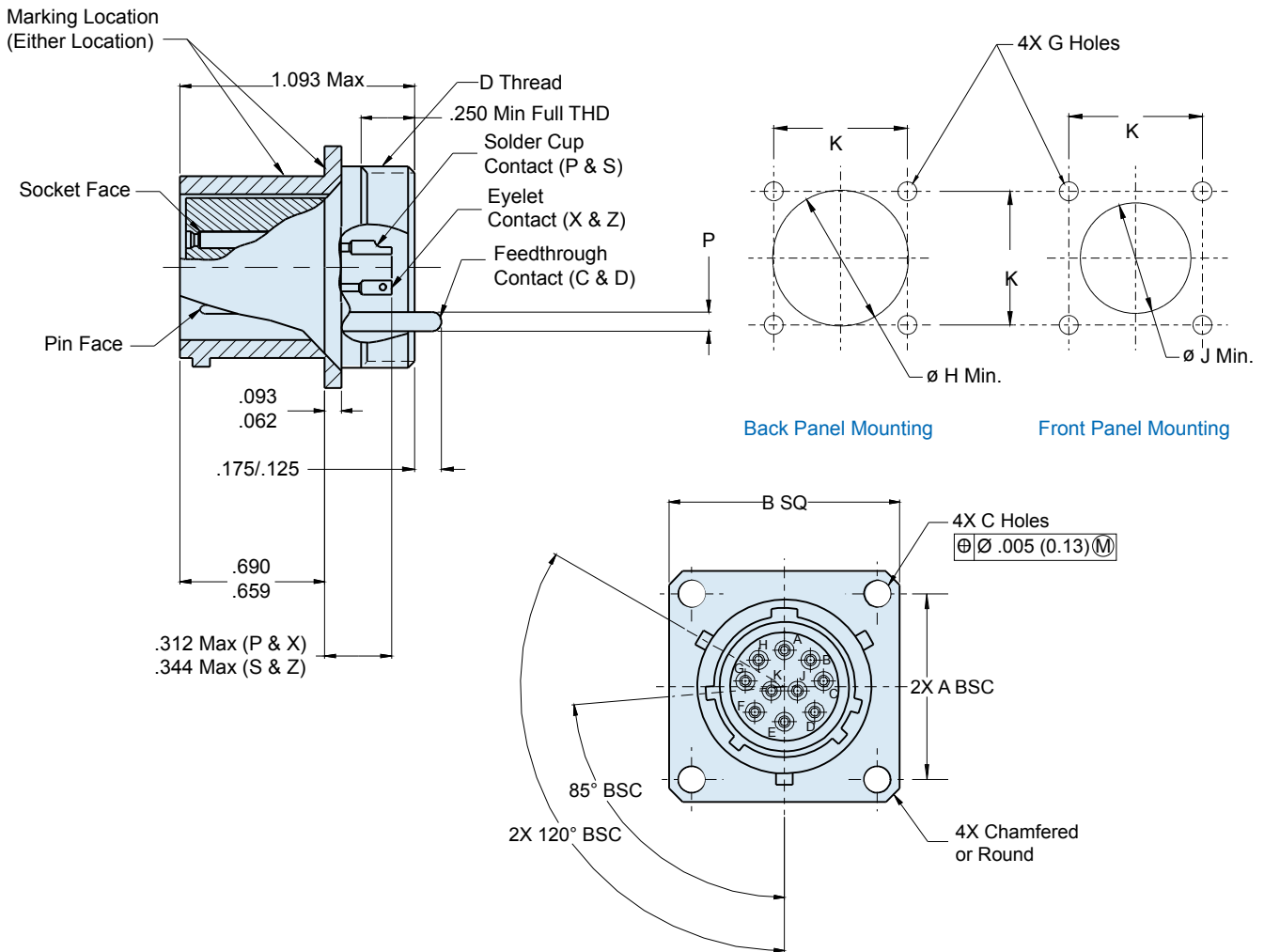
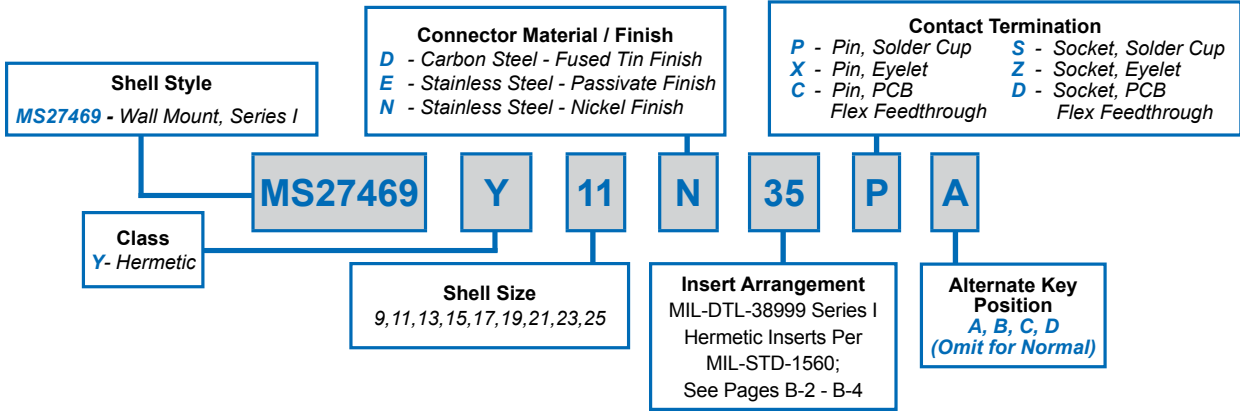

MS27469 Wall Mount Hermetic Receptacle MIL-DTL-38999 Series I



D38999 QPL
Hermetics

How To Order: Commercial

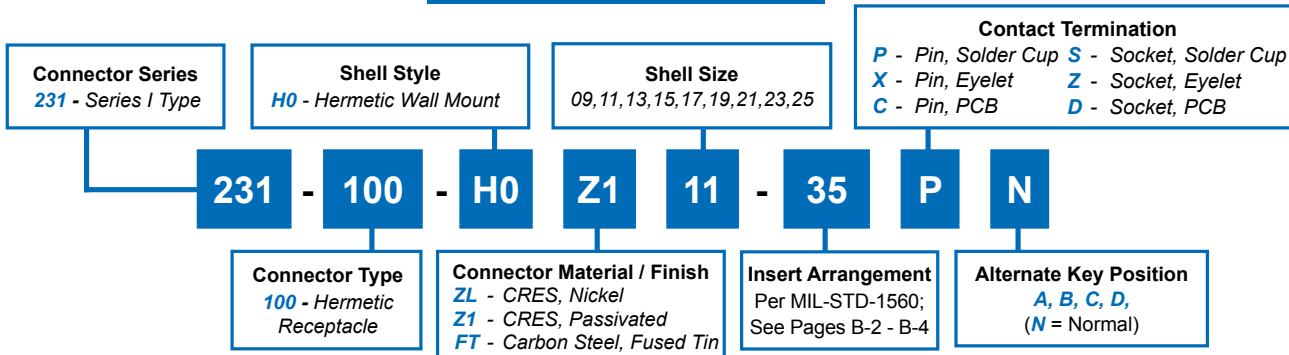

B

TABLE I: CONNECTOR DIMENSIONS

SHELL SIZE	A BSC	B SQ ±.016(0.4)	ø C HOLES	D THREADS
9/09	.719(18.3)	.938(23.8)	.133(3.4) .123(3.1)	.6875-24 UNEF-2A
11	.812(20.6)	1.031(26.2)	.133(3.4) .123(3.1)	.8125-20 UNEF-2A
13	.906(23.0)	1.125(28.6)	.133(3.4) .123(3.1)	.9375-20 UNEF-2A
15	.969(24.6)	1.219(31.0)	.133(3.4) .123(3.1)	1.0625-18 UNEF-2A
17	1.062(27.0)	1.312(33.3)	.133(3.4) .123(3.1)	1.1875-18 UNEF-2A
19	1.156(29.4)	1.438(36.5)	.133(3.4) .123(3.1)	1.3125-18 UNEF-2A
21	1.250(31.8)	1.562(39.7)	.133(3.4) .123(3.1)	1.4375-10 UNEF-2A
23	1.375(34.9)	1.688(42.9)	.157(4.0) .142(3.6)	1.5625-18 UNEF-2A
25	1.500(38.1)	1.812(46.0)	.157(4.0) .142(3.6)	1.6875-18 UNEF-2A

TABLE I (CONTINUED):
CONNECTOR DIMENSIONS

SHELL SIZE	ø G HOLES ±.005(0.1)	ø H MIN	ø J MIN	K ±.005(0.1)
9/09	.128(3.3)	.656(16.7)	.516(13.1)	.719(18.3)
11	.128(3.3)	.781(19.8)	.625(15.9)	.812(20.6)
13	.128(3.3)	.921(23.4)	.750(19.1)	.906(23.0)
15	.128(3.3)	1.047(26.6)	.906(23.0)	.968(24.6)
17	.128(3.3)	1.218(30.9)	1.016(25.8)	1.062(27.0)
19	.128(3.3)	1.296(32.9)	1.142(29.0)	1.156(29.4)
21	.128(3.3)	1.421(36.1)	1.266(32.2)	1.250(31.8)
23	.154(3.9)	1.546(39.3)	1.375(34.9)	1.375(34.9)
25	.154(3.9)	1.672(42.5)	1.484(37.7)	1.500(38.1)

TABLE II: CONTACT SIZE

PRINTED CIRCUIT TAIL CONFIGURATIONS
CONTACT STYLE C AND D

SIZE 12 AND SIZE 16

SIZE 22D AND SIZE 20

Contact Size	ø P
22D	.011 (0.28) .015 (0.38)
20	.024 (0.61) .028 (0.71)
16	.0635 (1.61) .0615 (1.56)
12	.095 (2.41) .093 (2.36)



MS27470 Jam Nut Mount Hermetic Receptacle MIL-DTL-38999 Series I

How To Order: MS

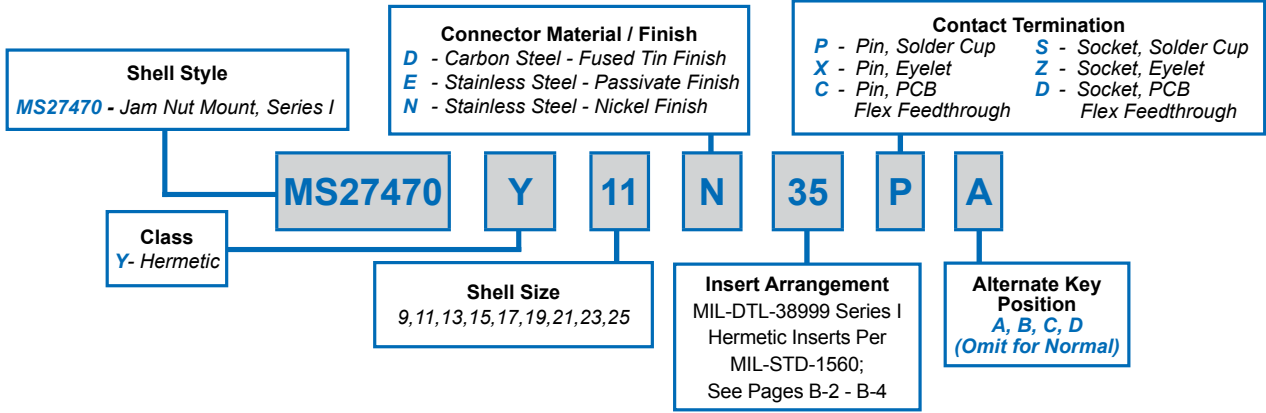

B

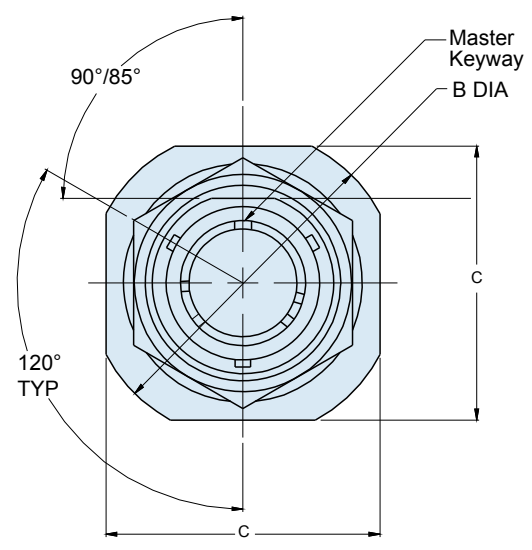
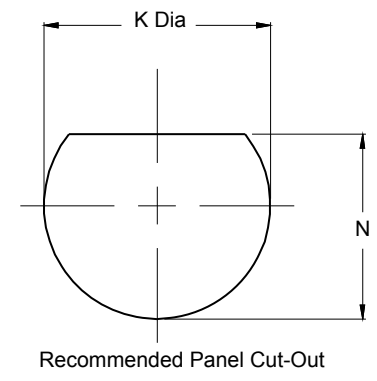
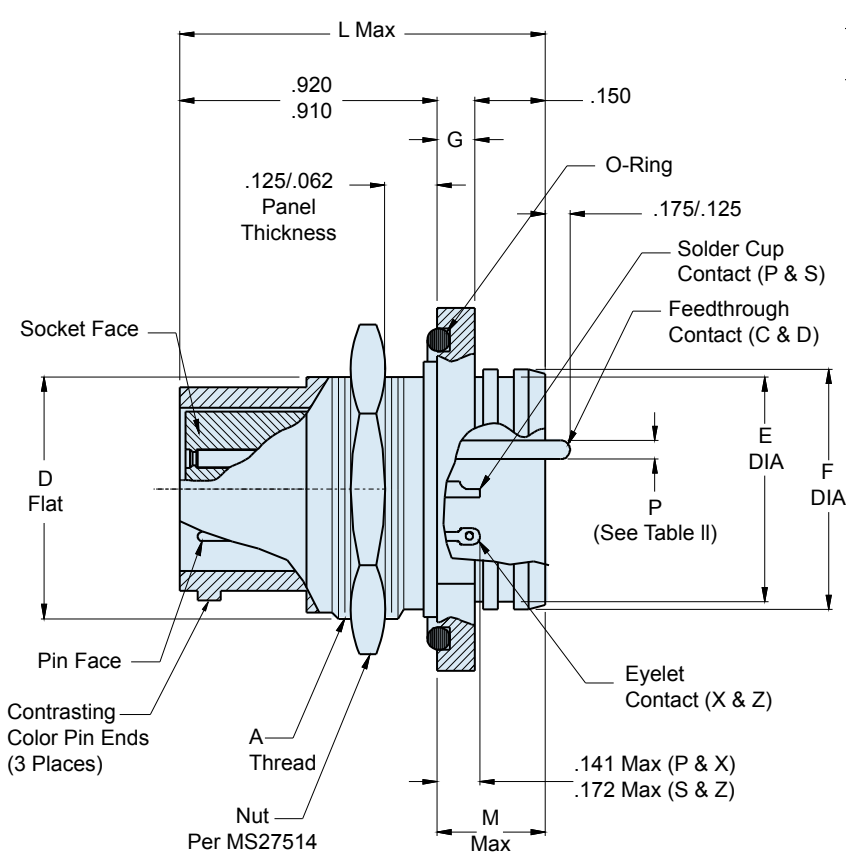

MS27470 Jam Nut Mount Hermetic Receptacle MIL-DTL-38999 Series I



D38999 QPL
Hermetics

How To Order: Commercial

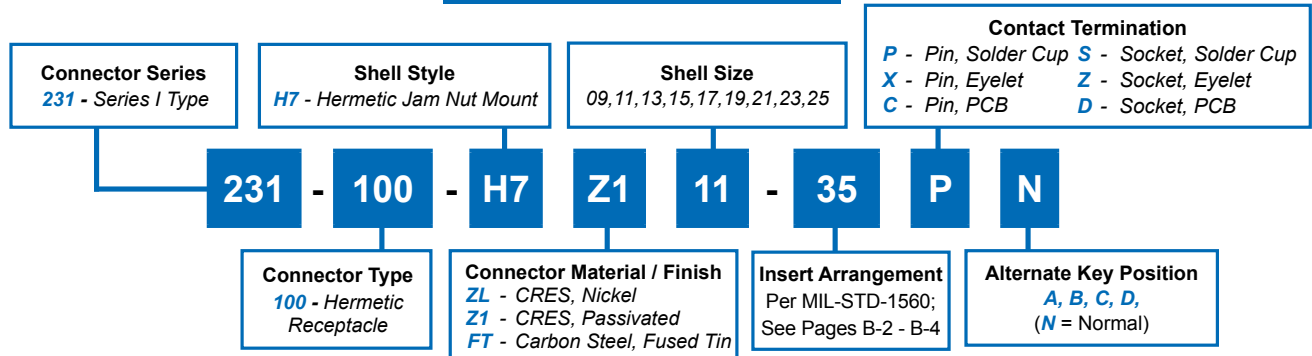

B

TABLE I: CONNECTOR DIMENSIONS

SHELL SIZE	A THREAD CLASS 2A	B DIA ±.016(0.4)	C ±.016(0.4)	D FLAT ±.005(0.1)	E DIA ±.011(0.3)	F DIA ±.005(0.1)
9/09	.6875-24 UNEF	1.188(30.2)	1.062(27.0)	.65(16.5)	.602(15.3)	.648(16.5)
11	.8125-20 UNEF	1.375(34.9)	1.25(31.8)	.75(19.1)	.726(18.4)	.772(19.6)
13	1.000-20 UNEF	1.5(38.1)	1.375(34.9)	.937(23.8)	.852(21.6)	.898(22.8)
15	1.125-18 UNEF	1.625(41.3)	1.5(38.1)	1.061(26.9)	.978(24.8)	1.024(26.0)
17	1.250-18 UNEF	1.75(44.5)	1.625(41.3)	1.186(30.1)	1.102(28.0)	1.148(29.2)
19	1.375-18 UNEF	1.938(49.2)	1.812(46.0)	1.311(33.3)	1.228(31.2)	1.274(32.4)
21	1.500-18 UNEF	2.062(52.4)	1.938(49.2)	1.436(36.5)	1.352(34.3)	1.398(35.5)
23	1.625-18 UNEF	2.188(55.6)	2.062(52.4)	1.561(39.6)	1.478(37.5)	1.524(38.7)
25	1.750-18 UNS	2.312(58.7)	2.188(55.6)	1.686(42.8)	1.602(40.7)	1.648(41.9)

TABLE I (CONTINUED): CONNECTOR DIMENSIONS

SHELL SIZE	G ±.016 (0.4)	K DIA ±.005 (0.1)	L MAX	M MAX	N +.000 -.002 (.05)
9/09	.109 (2.8)	.698 (17.7)	1.200 (30.5)	.280 (7.1)	.698 (17.7)
11	.109 (2.8)	.830 (21.1)	1.200 (30.5)	.280 (7.1)	.830 (21.1)
13	.109 (2.8)	1.015 (25.8)	1.200 (30.5)	.280 (7.1)	1.015 (25.8)
15	.109 (2.8)	1.140 (29.0)	1.200 (30.5)	.280 (7.1)	1.140 (29.0)
17	.109 (2.8)	1.265 (32.1)	1.200 (30.5)	.280 (7.1)	1.265 (32.1)
19	.140 (3.6)	1.390 (35.3)	1.231 (31.3)	.311 (7.9)	1.390 (35.3)
21	.140 (3.6)	1.515 (38.5)	1.231 (31.3)	.311 (7.9)	1.515 (38.5)
23	.140 (3.6)	1.640 (41.7)	1.231 (31.3)	.311 (7.9)	1.640 (41.7)
25	.140 (3.6)	1.765 (44.8)	1.231 (31.3)	.311 (7.9)	1.765 (44.8)

TABLE II: CONTACT SIZE

PRINTED CIRCUIT TAIL CONFIGURATIONS
CONTACT STYLE C AND D



SIZE 12 AND SIZE 16

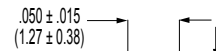

SIZE 22D AND SIZE 20

Contact Size	ø P
22D	.011 (0.28) .015 (0.38)
20	.024 (0.61) .028 (0.71)
16	.0635 (1.61) .0615 (1.56)
12	.095 (2.41) .093 (2.36)

MS27471 Solder Mount Hermetic Receptacle MIL-DTL-38999 Series I

How To Order: MS

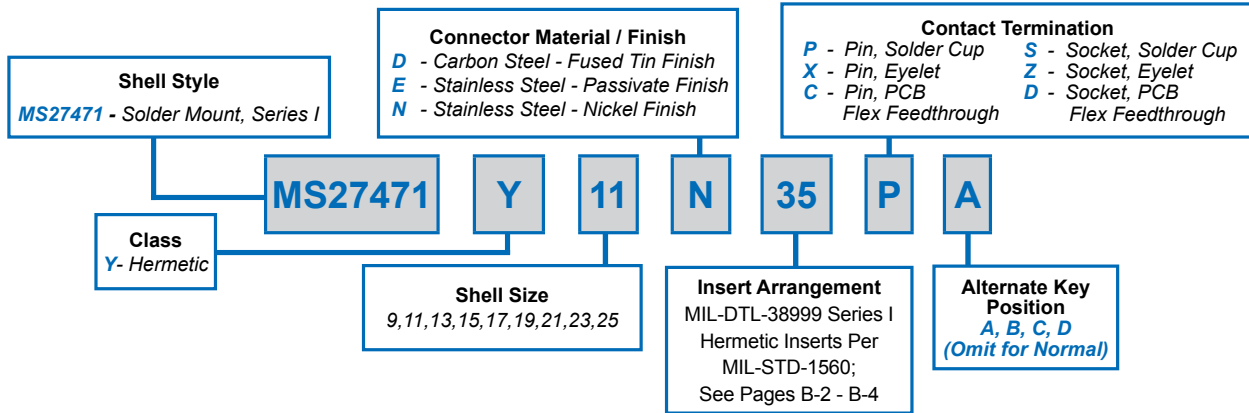

B

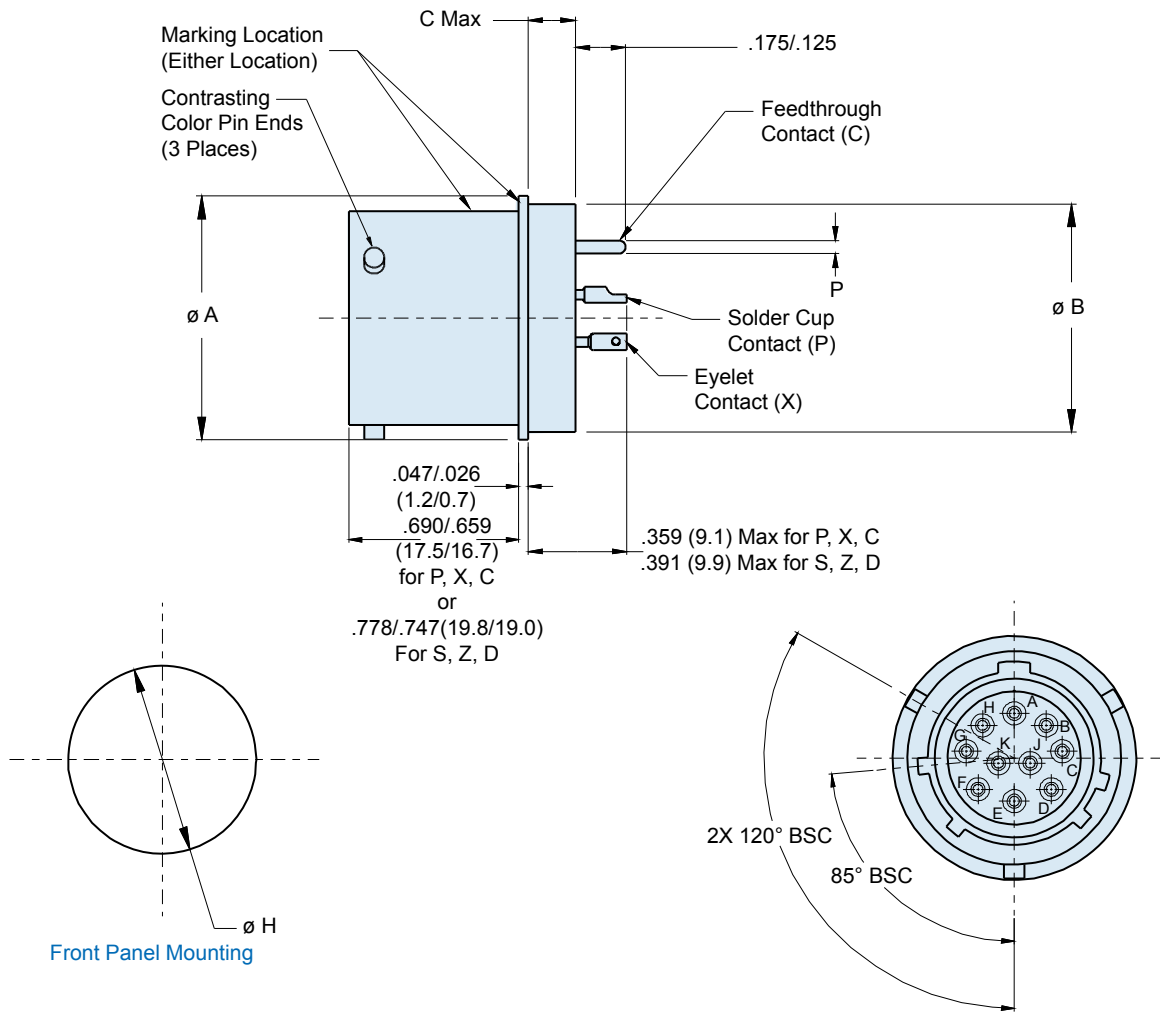

MS27471
Solder Mount Hermetic Receptacle
MIL-DTL-38999 Series I



D38999 QPL
 Hermetics

How To Order: Commercial

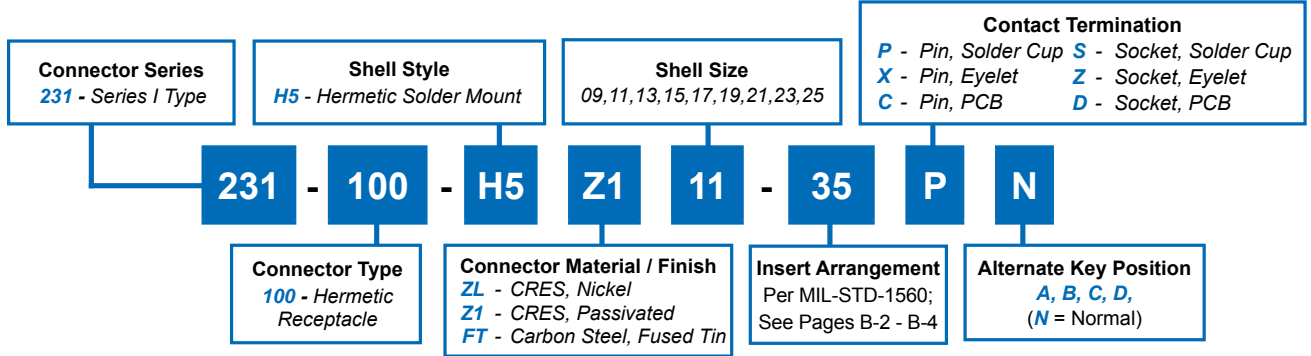

B

TABLE I: CONNECTOR DIMENSIONS

SHELL SIZE	ø A ±.016(0.4)	ø B	C MAX	ø H ±.005(0.1)
9/09	.750(19.1)	.673(17.1) .667(16.9)	.187(4.7)	.680(17.3)
11	.844(21.4)	.782(19.9) .776(19.7)		.789(20.0)
13	.969(24.6)	.907(23.0) .901(22.9)		.914(23.2)
15	1.094(27.8)	1.032(26.2) 1.027(26.1)		1.038(26.4)
17	1.218(30.9)	1.157(29.4) 1.151(29.2)		1.164(29.6)
19	1.312(33.3)	1.251(31.8) 1.245(31.6)		1.258(32.0)
21	1.438(36.5)	1.376(35.0) 1.370(34.8)		1.383(35.1)
23	1.563(39.7)	1.501(38.1) 1.495(38.0)	.218(5.5)	1.508(38.3)
25	1.688(42.9)	1.626(41.3) 1.620(41.1)		1.643(41.7)

TABLE II: CONTACT SIZE

PRINTED CIRCUIT TAIL CONFIGURATIONS
 CONTACT STYLE C AND D

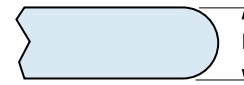

SIZE 12 AND SIZE 16

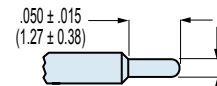

SIZE 22D AND SIZE 20

Contact Size	ø P
22D	.011 (0.28) .015 (0.38)
20	.024 (0.61) .028 (0.71)
16	.0635 (1.61) .0615 (1.56)
12	.095 (2.41) .093 (2.36)

How To Order: MS

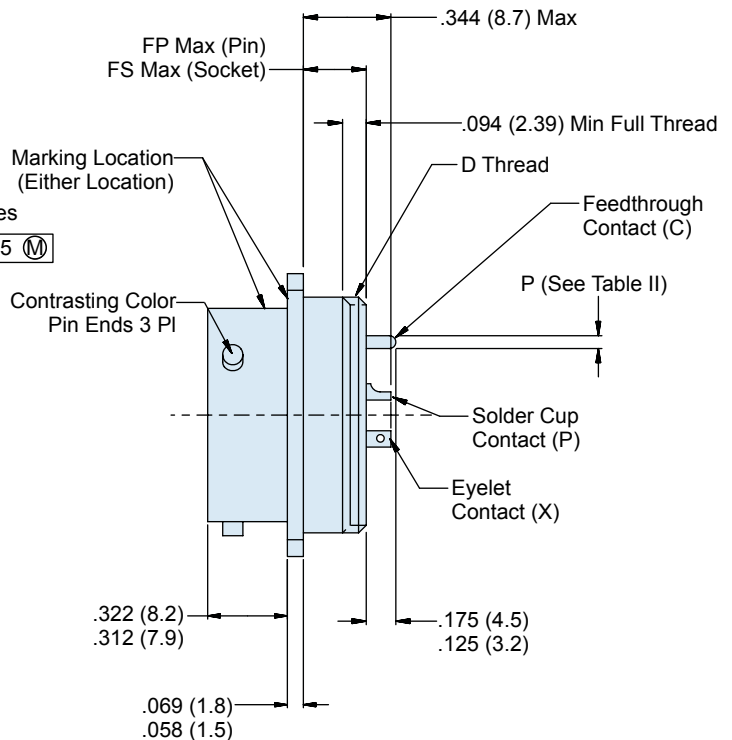
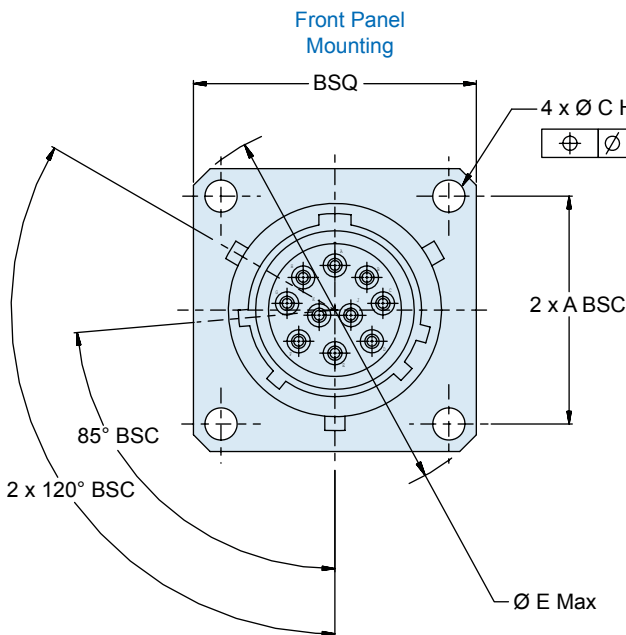
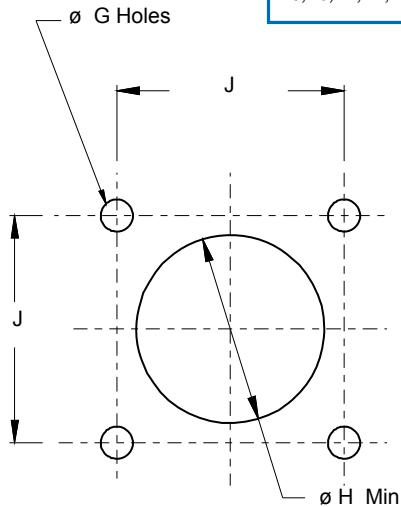
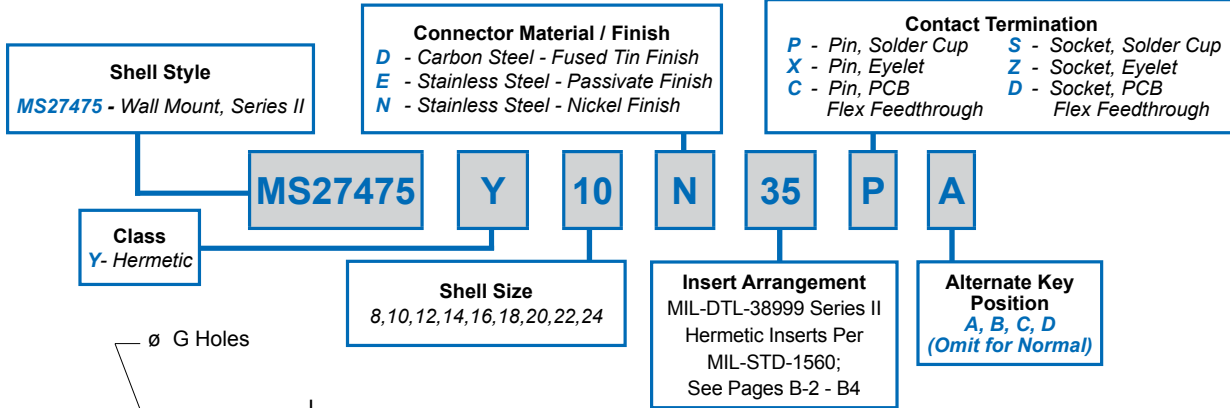

MS27475 Wall Mount Hermetic Receptacle MIL-DTL-38999 Series II



D38999 QPL
Hermetics

How To Order: Commercial

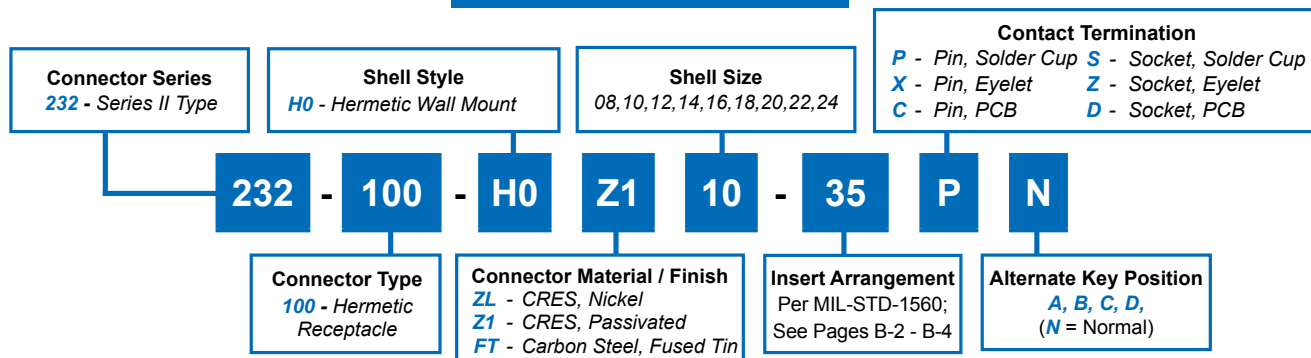

B

TABLE I: CONNECTOR DIMENSIONS

SHELL SIZE	A BSC	B SQ MAX	Ø C HOLES	D Threads (UNEF-2A)	Ø E MAX	FP MAX	FS MAX
8/08	.594(15.1)	.828(21.0)	.130(3.3) .115(2.9)	.5625-24	1.078(27.4)	.250 (6.35)	.375 (9.5)
10	.719(18.3)	.954(24.2)		.6875-24	1.256(31.9)		
12	.812(20.6)	1.047(26.6)		.8125-20	1.391(35.3)		
14	.906(23.0)	1.141(29.0)		.9375-20	1.516(38.5)		
16	.969(24.6)	1.234(31.3)		1.0625-18	1.641(41.7)		
18	1.062(27.0)	1.328(33.7)		1.1875-18	1.766(44.9)		
20	1.156(29.4)	1.453(36.9)		1.3125-18	1.891(48.0)		
22	1.250(31.8)	1.578(40.1)		1.4375-10	2.016(51.2)		
24	1.375(34.9)	1.703(43.3)	.157(4.0) .142(3.6)	1.5625-18	2.204(56.0)	.375 (9.53)	.406 (10.3)

TABLE II: CONTACT SIZE

PRINTED CIRCUIT TAIL CONFIGURATIONS
CONTACT STYLE C AND D

Contact Size	Ø P
22D	.011 (0.28) .015 (0.38)
20	.024 (0.61) .028 (0.71)
16	.0635 (1.61) .0615 (1.56)
12	.095 (2.41) .093 (2.36)

**TABLE I (CONTINUED):
CONNECTOR DIMENSIONS**

SHELL SIZE	Ø G HOLES	Ø H MIN	Ø J BSC
8	.133(3.4) .123(3.1)	.570(14.5)	.594(15.1)
10		.690(17.5)	.719(18.3)
12		.820(20.8)	.812(20.6)
14		.940(23.9)	.906(23.0)
16		1.070(27.2)	.969(24.6)
18		1.190(30.2)	1.062(27.0)
20		1.320(33.5)	1.156(29.4)
22		.159(4.0)	1.440(36.6)
24	.149(3.8)	1.570(39.9)	1.375(34.9)

How To Order: MS

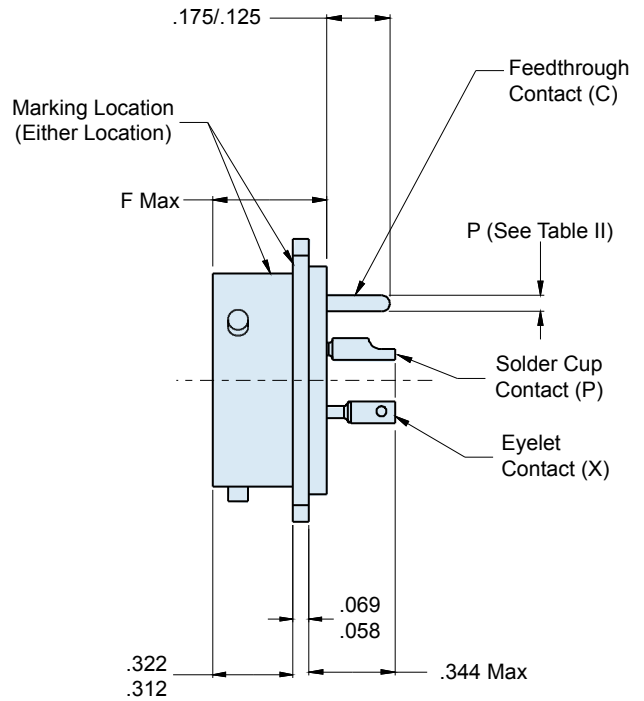
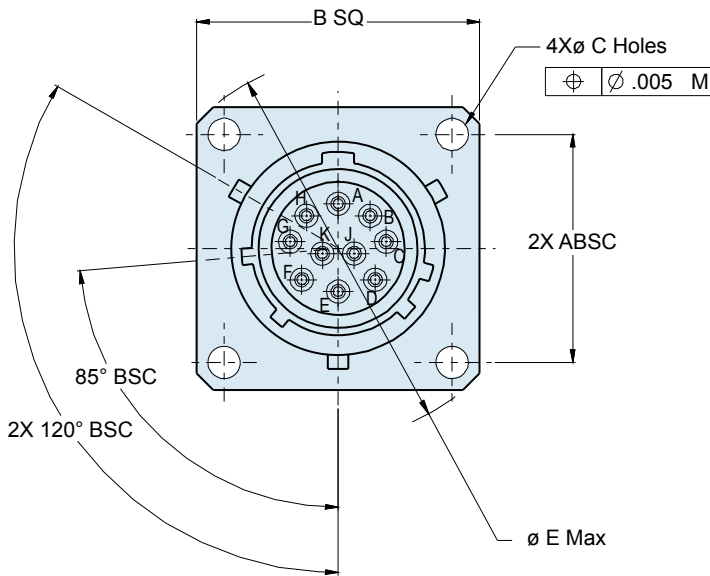
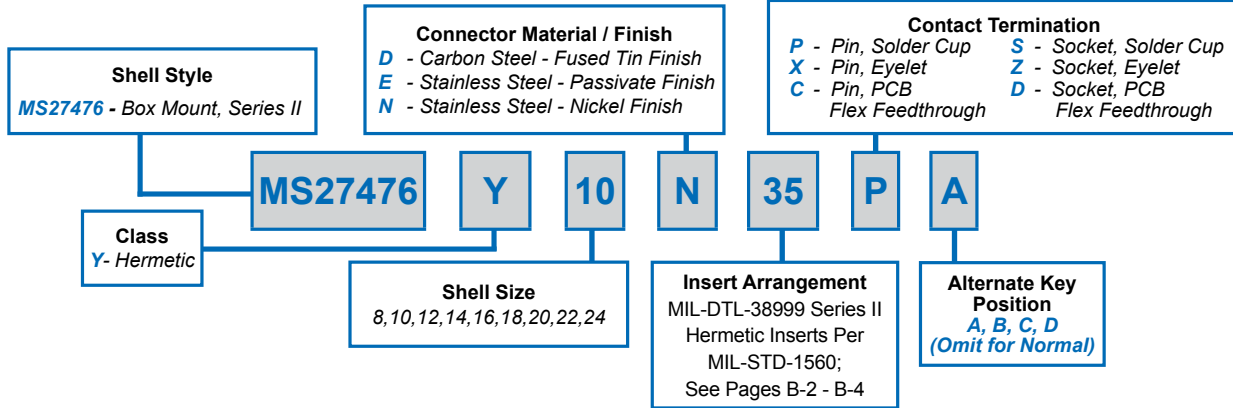

MS27476
Box Mount Hermetic Receptacle
MIL-DTL-38999 Series II



D38999 QPL
 Hermetics

How To Order: Commercial

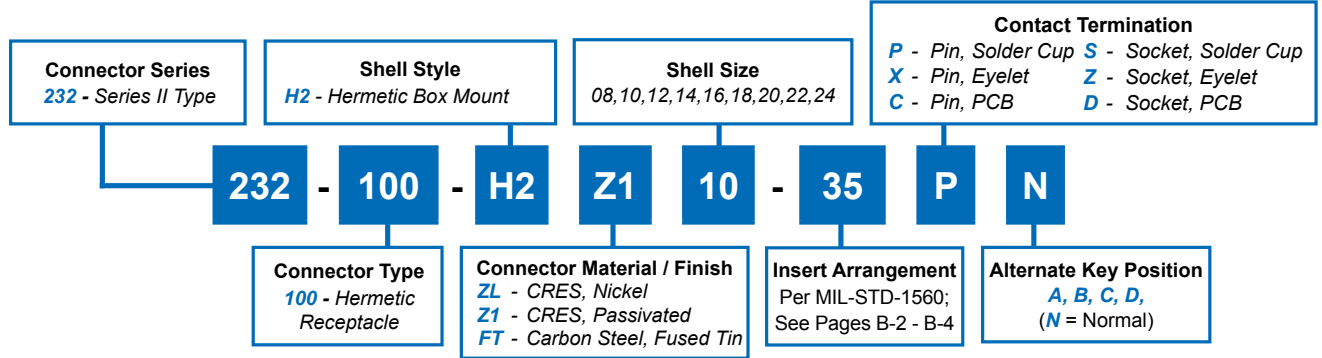

B

TABLE I: CONNECTOR DIMENSIONS

SHELL SIZE	A BSC	B SQ MAX	Ø C HOLES	Ø E MAX	F MAX
8/08	.594(15.1)	.828(21.0)	.130(3.3) .115(2.9)	1.078(27.4)	.453(11.5)
10	.719(18.3)	.954(24.2)		1.266(32.2)	
12	.812(20.6)	1.047(26.6)		1.391(35.3)	
14	.906(23.0)	1.141(29.0)		1.516(38.5)	
16	.969(24.6)	1.234(31.3)		1.641(41.7)	
18	1.062(27.0)	1.328(33.7)		1.766(44.9)	
20	1.156(29.4)	1.453(36.9)		1.891(48.0)	
22	1.250(31.8)	1.578(40.1)		2.016(51.2)	
24	1.375(34.9)	1.703(43.3)	.157(4.0) .142(3.6)	2.204(56.0)	.484(12.3)

TABLE II: CONTACT SIZE

PRINTED CIRCUIT TAIL CONFIGURATIONS
CONTACT STYLE C AND D

Contact Size	Ø P
22D	.011 (0.28) .015 (0.38)
20	.024 (0.61) .028 (0.71)
16	.0635 (1.61) .0615 (1.56)
12	.095 (2.41) .093 (2.36)

TABLE I (CONTINUED): CONNECTOR DIMENSIONS

SHELL SIZE	Ø G HOLES	Ø H MIN	Ø J BSC
8/08	.133(3.4) .123(3.1)	.570(14.5)	.594(15.1)
10		.690(17.5)	.719(18.3)
12		.820(20.8)	.812(20.6)
14		.940(23.9)	.906(23.0)
16		1.070(27.2)	.969(24.6)
18		1.190(30.2)	1.062(27.0)
20		1.320(33.5)	1.156(29.4)
22		.159(4.0) .149(3.8)	1.440(36.6)
24		1.570(39.9)	1.375(34.9)

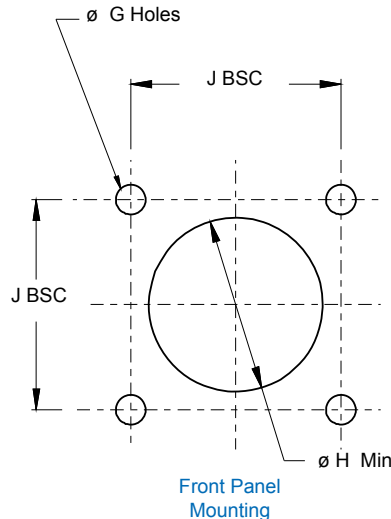



MS27477 Jam Nut Mount Hermetic Receptacle MIL-DTL-38999 Series II

How To Order: MS

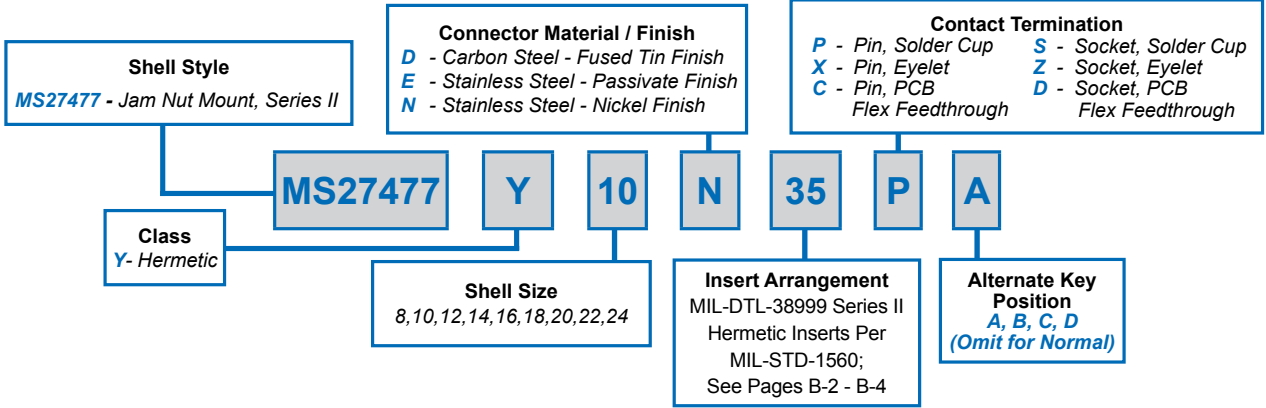

B

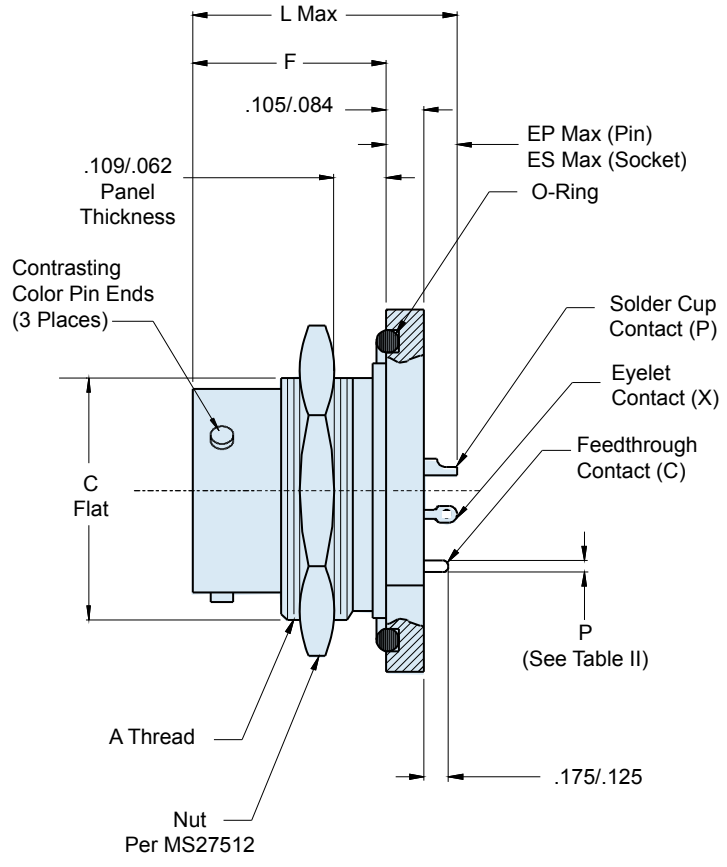
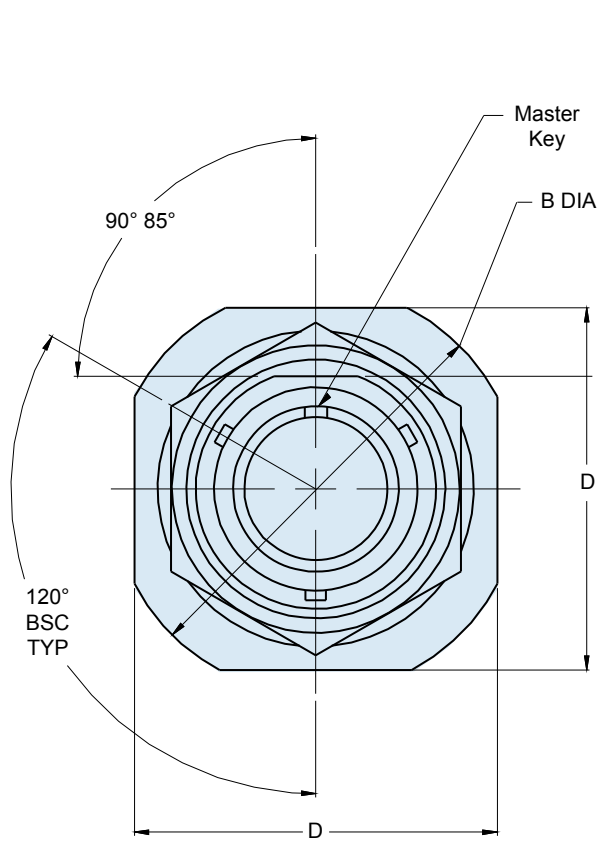

MS27477 Jam Nut Mount Hermetic Receptacle MIL-DTL-38999 Series II



D38999 QPL
Hermetics

How To Order: *Commercial*

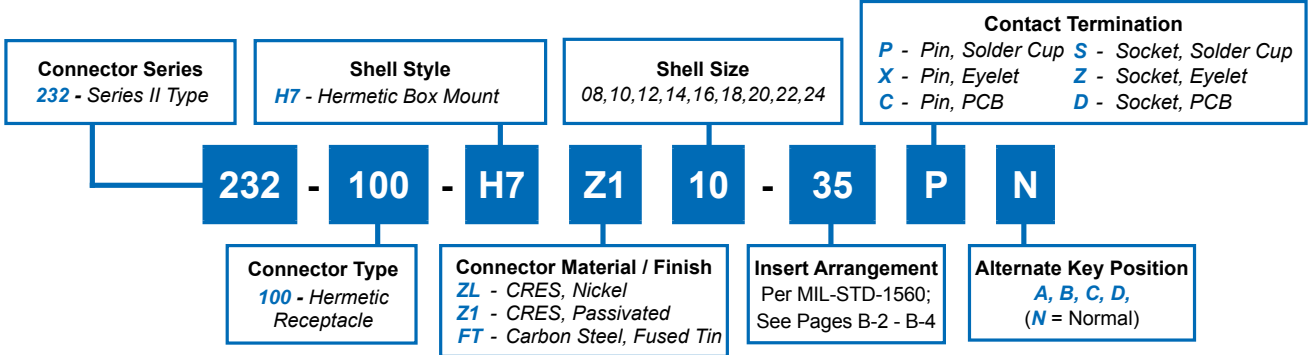

B

TABLE I: CONNECTOR DIMENSIONS				
SHELL SIZE	A THREAD CLASS 2A	B DIA ±.016(0.4)	C FLAT ±.004(0.1)	D A/F ±.016(0.4)
8/08	.875-20 UNEF	1.375(34.9)	.815(20.7)	1.25(31.8)
10	1.000-20 UNEF	1.5(38.1)	.939(23.9)	1.375(34.9)
12	1.125-18 UNEF	1.625(41.3)	1.063(27.0)	1.5(38.1)
14	1.250-18 UNEF	1.75(44.5)	1.188(30.2)	1.625(41.3)
16	1.375-18 UNEF	1.938(49.2)	1.318(33.5)	1.781(45.2)
18	1.500-18 UNEF	2.016(51.2)	1.438(36.5)	1.890(48.0)
20	1.625-18 UNEF	2.141(54.4)	1.563(39.7)	2.016(51.2)
22	1.750-18 UNS	2.265(57.5)	1.688(42.9)	2.140(54.4)
24	1.875-16 UN	2.39(60.7)	1.813(46.1)	2.265(57.5)

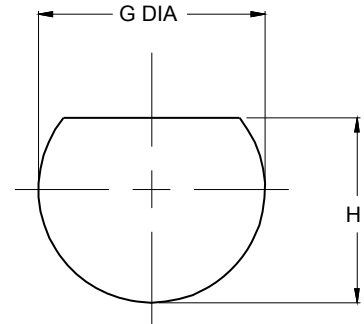

Recommended Panel Cut-Out

TABLE I (CONTINUED): CONNECTOR DIMENSIONS						
SHELL SIZE	EP MAX	ES MAX	F ±.005(0.1)	G DIA ±.005(0.1)	H ±.005(0.1)	L MAX
8/08	.281 (7.1)	.359 (9.1)	.438(11.1)	.889(22.6)	.828(21.0)	.724(18.4)
10	.281 (7.1)	.359 (9.1)	.438(11.1)	1.015(25.8)	.952(24.2)	.724(18.4)
12	.281 (7.1)	.359 (9.1)	.438(11.1)	1.139(28.9)	1.076(27.3)	.724(18.4)
14	.281 (7.1)	.359 (9.1)	.438(11.1)	1.264(32.1)	1.201(30.5)	.724(18.4)
16	.281 (7.1)	.359 (9.1)	.438(11.1)	1.389(35.3)	1.331(33.8)	.724(18.4)
18	.281 (7.1)	.359 (9.1)	.438(11.1)	1.515(38.5)	1.451(36.9)	.724(18.4)
20	.250 (6.4)	.344 (8.7)	.464(11.8)	1.640(41.7)	1.576(40.0)	.719(18.3)
22	.250 (6.4)	.344 (8.7)	.464(11.8)	1.745(44.3)	1.701(43.2)	.719(18.3)
24	.250 (6.4)	.344 (8.7)	.464(11.8)	1.890(48.0)	1.826(46.4)	.719(18.3)

TABLE II: CONTACT SIZE	
PRINTED CIRCUIT TAIL CONFIGURATIONS CONTACT STYLE C AND D	
SIZE 12 AND SIZE 16	$.050 \pm .015$ (1.27 ± 0.38)
SIZE 22D AND SIZE 20	$.050 \pm .015$ (1.27 ± 0.38)
Contact Size	ø P
22D	.011 (0.28) .015 (0.38)
20	.024 (0.61) .028 (0.71)
16	.0635 (1.61) .0615 (1.56)
12	.095 (2.41) .093 (2.36)



MS27478 Solder Mount Hermetic Receptacle MIL-DTL-38999 Series II

How To Order: MS

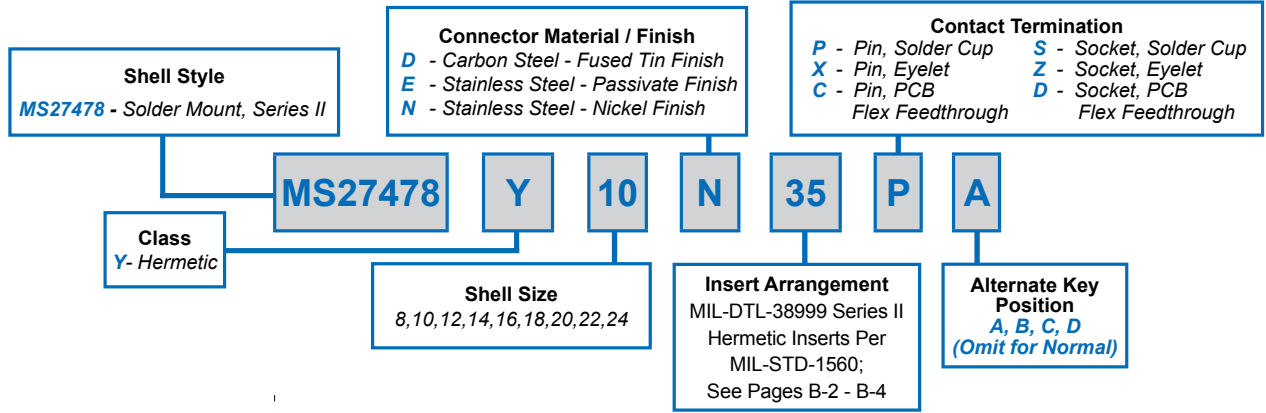

B

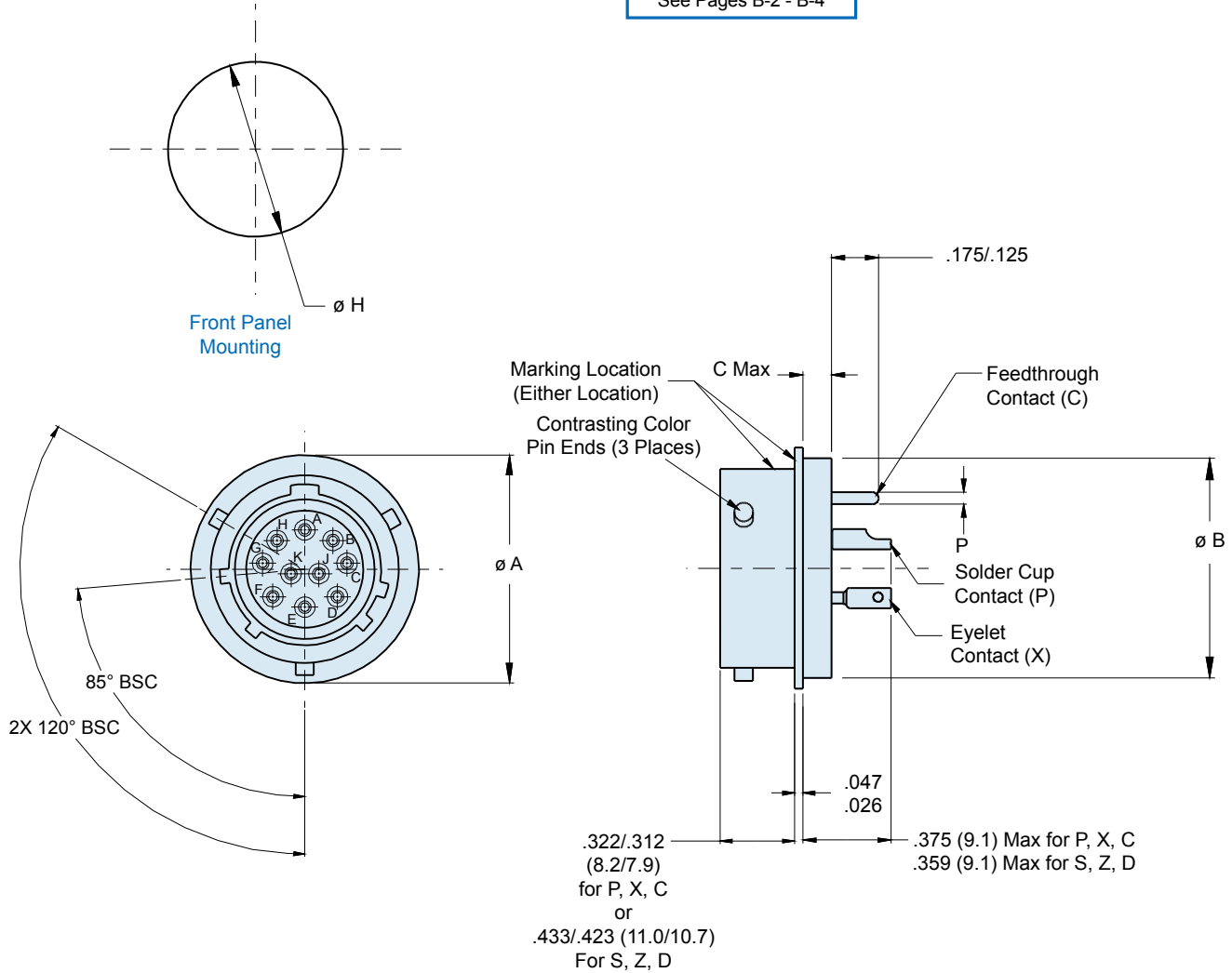

MS27478
Solder Mount Hermetic Receptacle
MIL-DTL-38999 Series II



D38999 QPL
 Hermetics

How To Order: Commercial

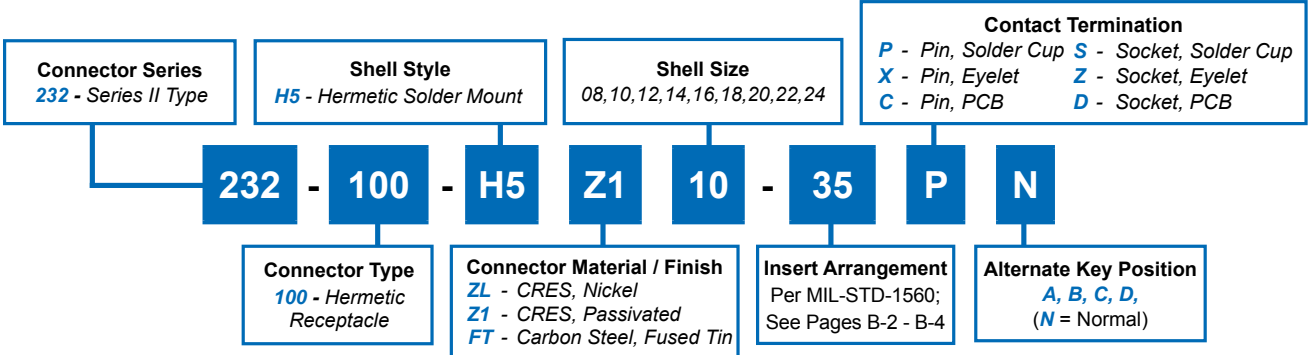

B

TABLE I: CONNECTOR DIMENSIONS

SHELL SIZE	ø A ±.011(0.3)	ø B	C MAX	ø H ±.005(0.1)
8/08	.688(17.5)	.557(14.) .557(14.1)	.125(3.2)	.570(14.5)
10	.798(20.3)	.673(17.1) .667(16.9)		.680(17.3)
12	.907(23.0)	.782(19.9) .776(19.7)		.789(20.0)
14	1.032(26.2)	.907(23.0) .901(22.9)		.914(23.2)
16	1.157(29.4)	1.032(26.2) 1.027(26.1)		1.039(26.4)
18	1.282(32.6)	1.157(29.4) 1.151(29.2)		1.164(29.6)
20	1.376(35.0)	1.251(31.8) 1.245(31.6)		1.258(32.0)
22	1.501(38.1)	1.376(35.0) 1.370(34.8)	.156(4.0)	1.383(35.1)
24	1.626(41.3)	1.501(38.1) 1.495(38.0)		1.508(38.3)

TABLE II: CONTACT SIZE

**PRINTED CIRCUIT TAIL CONFIGURATIONS
CONTACT STYLE C AND D**

Contact Size	ø P
22D	.011 (0.28) .015 (0.38)
20	.024 (0.61) .028 (0.71)
16	.0635 (1.61) .0615 (1.56)
12	.095 (2.41) .093 (2.36)

How To Order: MS

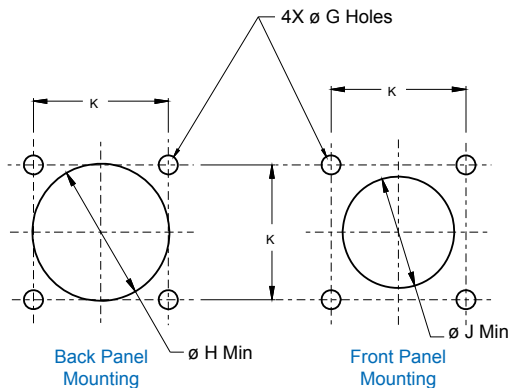
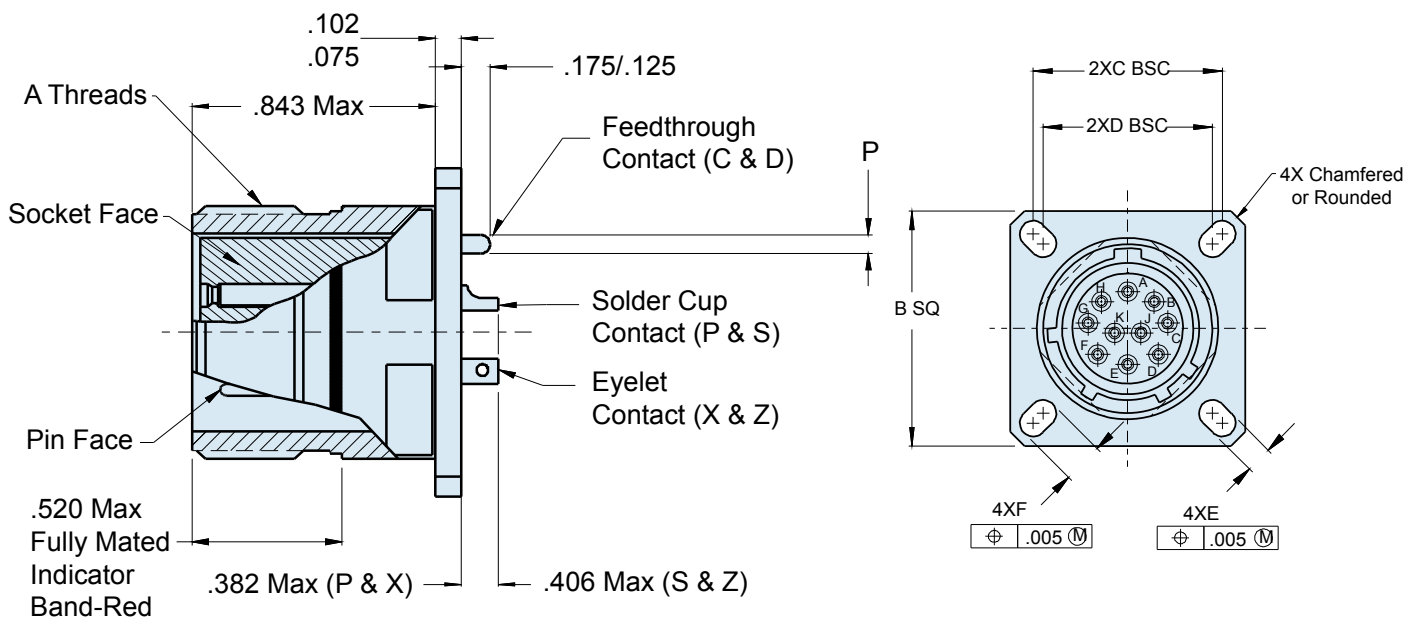
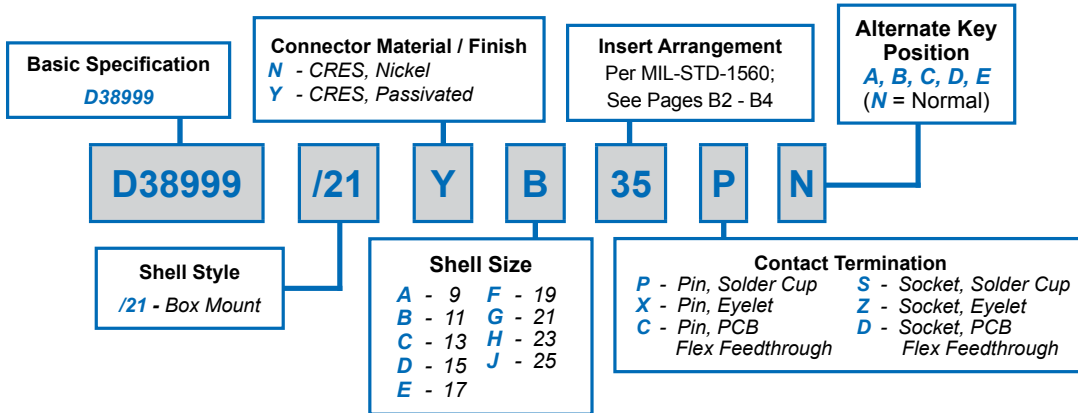

D38999/21 Box Mount Hermetic Receptacle MIL-DTL-38999 Series III



D38999 QPL
Hermetics

How To Order: Commercial

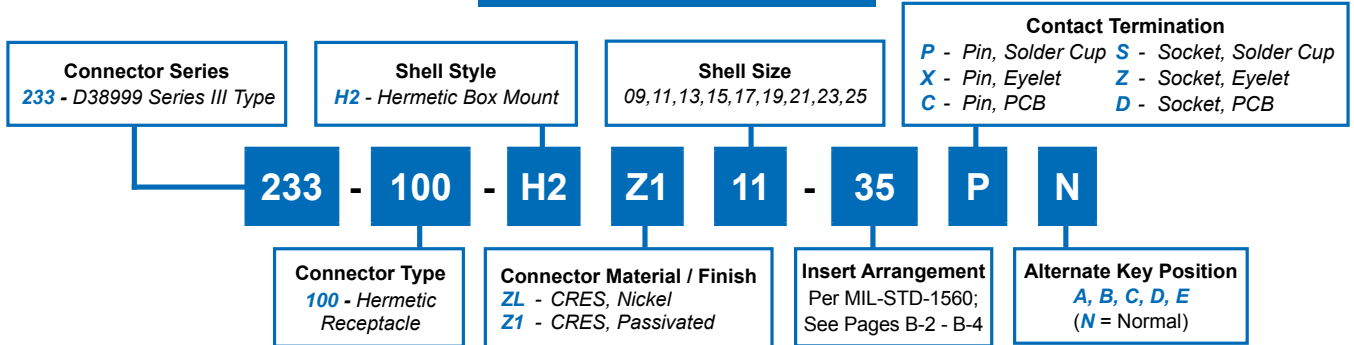

B

TABLE I: CONNECTOR DIMENSIONS

SHELL SIZE CODE	SHELL SIZE	A THREAD	B SQ ±.012(0.3)	C BSC	D BSC	E ±.008(0.2)	F ±.008(0.2)
A	9/09	.6250-.1P-.3L-TS-2A	.937(23.8)	.719(18.3)	.594(15.1)	.128(3.3)	.216(5.5)
B	11	.7500-.1P-.3L-TS-2A	1.031(26.2)	.812(20.6)	.719(18.3)	.128(3.3)	.194(4.9)
C	13	.8750-.1P-.3L-TS-2A	1.126(28.6)	.906(23.0)	.812(20.6)	.128(3.3)	.194(4.9)
D	15	1.0000-.1P-.3L-TS-2A	1.220(31.0)	.969(24.6)	.906(23.0)	.128(3.3)	.194(4.9)
E	17	1.1875-.1P-.3L-TS-2A	1.311(33.3)	1.062(27.0)	.969(24.6)	.128(3.3)	.194(4.9)
F	19	1.2500-.1P-.3L-TS-2A	1.437(36.5)	1.156(29.4)	1.062(27.0)	.128(3.3)	.194(4.9)
G	21	1.3750-.1P-.3L-TS-2A	1.563(39.7)	1.250(31.8)	1.156(29.4)	.128(3.3)	.194(4.9)
H	23	1.5000-.1P-.3L-TS-2A	1.689(42.9)	1.375(34.9)	1.250(31.8)	.154(3.9)	.242(6.1)
J	25	1.6250-.1P-.3L-TS-2A	1.811(46.0)	1.500(38.1)	1.375(34.9)	.154(3.9)	.242(6.1)

TABLE I (CONTINUED): CONNECTOR DIMENSIONS

SHELL SIZE CODE	SHELL SIZE	Ø G HOLES ±.005(0.1)	Ø H MIN	Ø J MIN	K ±.005(0.1)
A	9/09	.128(3.3)	.656(16.7)	.516(13.1)	.719(18.3)
B	11	.128(3.3)	.781(19.8)	.625(15.9)	.812(20.6)
C	13	.128(3.3)	.921(23.4)	.750(19.1)	.906(23.0)
D	15	.128(3.3)	1.047(26.6)	.906(23.0)	.968(24.6)
E	17	.128(3.3)	1.218(30.9)	1.016(25.8)	1.062(27.0)
F	19	.128(3.3)	1.296(32.9)	1.142(35.9)	1.156(29.4)
G	21	.128(3.3)	1.421(36.1)	1.266(32.2)	1.250(31.8)
H	23	.154(3.9)	1.546(39.3)	1.375(34.9)	1.375(34.9)
J	25	.154(3.9)	1.672(42.5)	1.484(37.7)	1.500(38.1)

TABLE II: CONTACT SIZE

PRINTED CIRCUIT TAIL CONFIGURATIONS
CONTACT STYLE C AND D



SIZE 12 AND SIZE 16

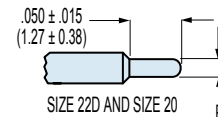

SIZE 22D AND SIZE 20

Contact Size	Ø P
22D	.011 (0.28) .015 (0.38)
20	.024 (0.61) .028 (0.71)
16	.0635 (1.61) .0615 (1.56)
12	.095 (2.41) .093 (2.36)

D38999/23 Jam Nut Mount Hermetic Receptacle MIL-DTL-38999 Series III

How To Order: **MS**

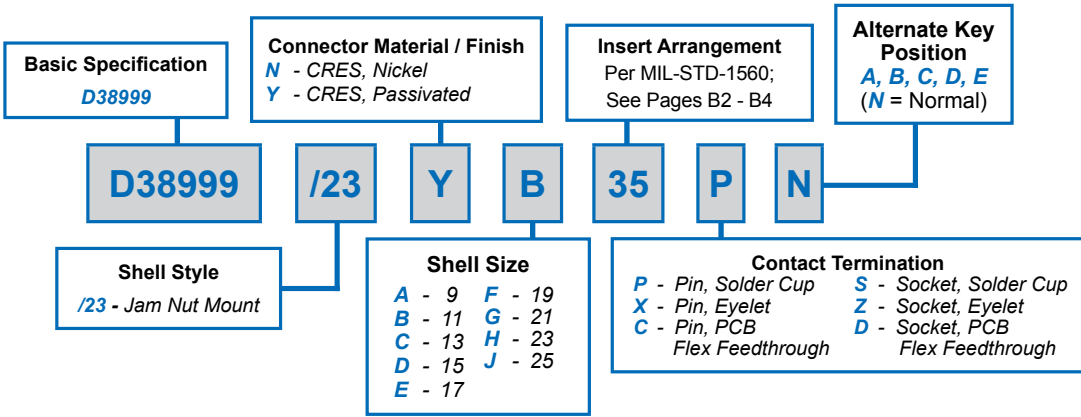

B

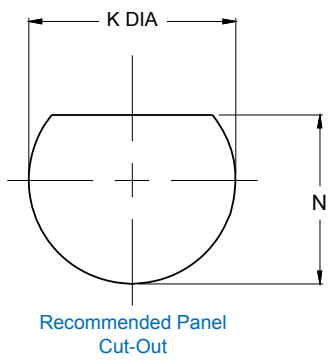
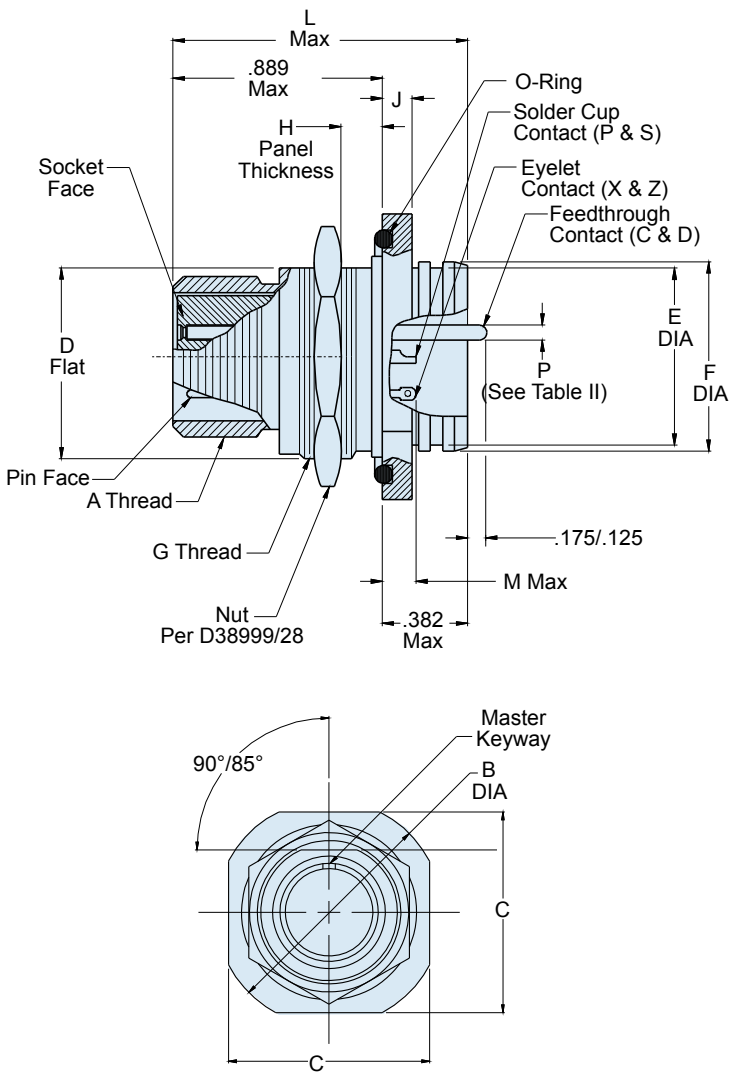

TABLE II: CONTACT SIZE

PRINTED CIRCUIT TAIL CONFIGURATIONS
CONTACT STYLE C AND D

Contact Size	ø P
22D	.011 (0.28)
	.015 (0.38)
20	.024 (0.61)
	.028 (0.71)
16	.0635 (1.61)
	.0615 (1.56)
12	.095 (2.41)
	.093 (2.36)

D38999/23
Jam Nut Mount Hermetic Receptacle
MIL-DTL-38999 Series III



D38999 QPL
 Hermetics

How To Order: Commercial

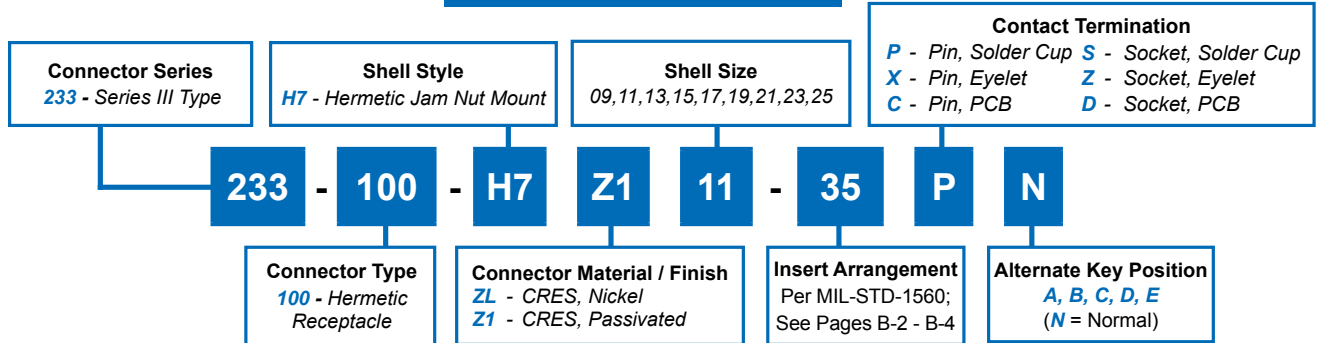

B

TABLE I: CONNECTOR DIMENSIONS

SHELL SIZE CODE	SHELL SIZE	A THREAD -0.1P-0.03L- TS	B DIA	C A/F ±.015(0.4)	D FLAT ±.005(0.1)	E DIA ±.012(0.3)	F DIA	G THREAD ISO METRIC	H ±.032(0.8)
A	9/09	0.625	1.200(30.5) 1.178(29.9)	1.063(27.0)	.650(16.5)	.603(15.3)	.653(16.6) .642(16.3)	M17 X 1.0-6g	.094(2.4)
B	11	0.750	1.385(35.2) 1.363(34.6)	1.252(31.8)	.750(19.1)	.725(18.4)	.775(19.7) .764(19.4)	M20 X 1.0-6g	.094(2.4)
C	13	0.875	1.511(38.4) 1.489(37.8)	1.374(34.9)	.937(23.8)	.851(21.6)	.905(23.0) .894(22.7)	M25 X 1.0-6g	.094(2.4)
D	15	1.000	1.637(41.6) 1.615(41.0)	1.500(38.1)	1.061(26.9)	.977(24.8)	1.031(26.2) 1.020(25.9)	M28 X 1.0-6g	.094(2.4)
E	17	1.187	1.763(44.8) 1.741(44.2)	1.626(41.3)	1.186(30.1)	1.103(28.0)	1.153(29.3) 1.142(29.0)	M32 X 1.0-6g	.094(2.4)
F	19	1.250	1.948(49.5) 1.926(48.9)	1.811(46.0)	1.311(33.3)	1.229(31.2)	1.278(32.5) 1.268(32.2)	M35 X 1.0-6g	.094(2.4)
G	21	1.375	2.074(52.7) 2.051(52.1)	1.937(49.2)	1.436(36.5)	1.351(34.3)	1.405(35.7) 1.394(35.4)	M38 X 1.0-6g	.094(2.4)
H	23	1.500	2.200(55.9) 2.177(55.3)	2.063(52.4)	1.561(39.6)	1.477(37.5)	1.531(38.9) 1.520(38.6)	M41 X 1.0-6g	.094(2.4)
J	25	1.625	2.322(59.0) 2.300(58.4)	2.189(55.6)	1.686(42.8)	1.603(40.7)	1.653(42.0) 1.642(41.7)	M44 X 1.0-6g	.094(2.4)

TABLE I: (Continued) CONNECTOR DIMENSIONS

J ±.008(0.2)	K DIA ±.005 (0.1)	L MAX	M MAX		N ±.005 (0.1)
			P&X	S&Z	
.106(2.7)	.703/.693 (17.86/17.60)	1.149(29.2)	.208(5.3)	.232(5.9)	.657/.655 (16.69/16.70)
.106(2.7)	.835/.825 (20.96/20.96)	1.149(29.2)	.208(5.3)	.232(5.9)	.771/.769 (19.58/19.53)
.106(2.7)	1.020/1.010 (25.65/25.65)	1.153(29.3)	.200(5.1)	.224(5.7)	.955/.953 (24.26/24.21)
.106(2.7)	1.145/1.135 (28.83/28.83)	1.153(29.3)	.200(5.1)	.224(5.7)	1.085/1.083 (27.56/27.51)
.106(2.7)	1.270/1.260 (32.01/32.00)	1.153(29.3)	.200(5.1)	.224(5.7)	1.210/1.208 (30.73/30.68)
.138(3.5)	1.395/1.385 (35.43/35.18)	1.185(30.1)	.200(5.1)	.224(5.7)	1.335/1.333 (33.91/33.86)
.138(3.5)	1.520/1.510 (38.60/38.35)	1.185(30.1)	.200(5.1)	.224(5.7)	1.460/1.458 (37.08/37.03)
.138(3.5)	1.645/1.635 (41.78/41.53)	1.185(30.1)	.200(5.1)	.224(5.7)	1.585/1.583 (40.26/40.21)
.138(3.5)	1.770/1.760 (44.96/44.70)	1.185(30.1)	.200(5.1)	.224(5.7)	1.710/1.708 (43.43/43.38)

D38999/25 Solder Mount Hermetic Receptacle MIL-DTL-38999 Series III

How To Order: *MS*

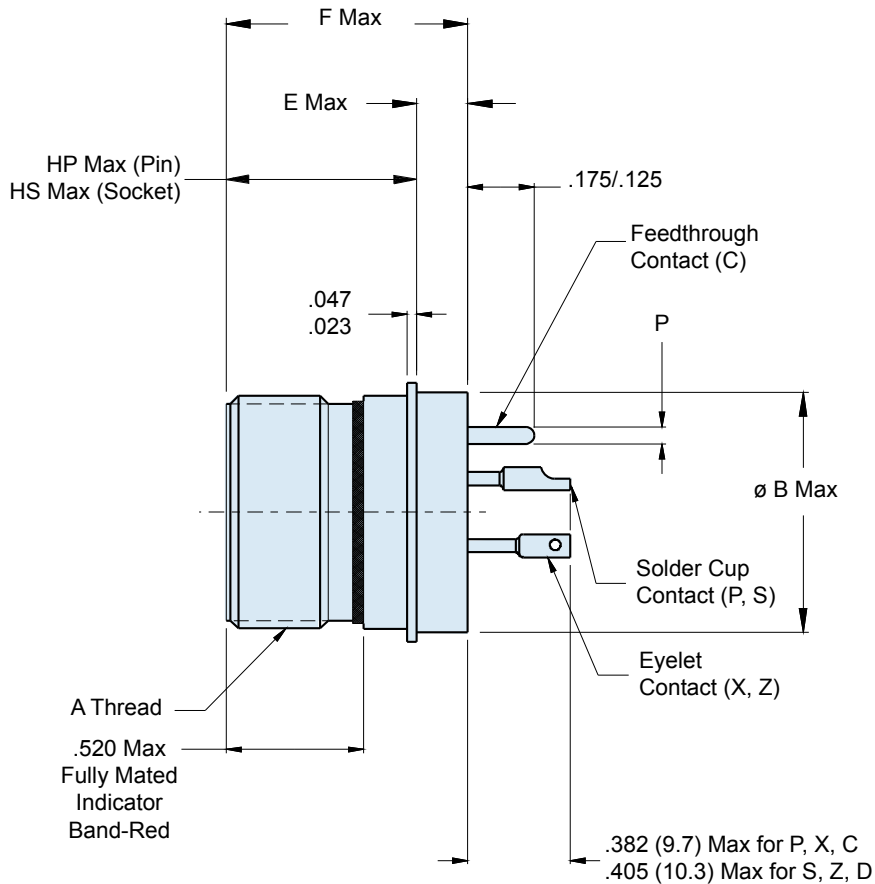
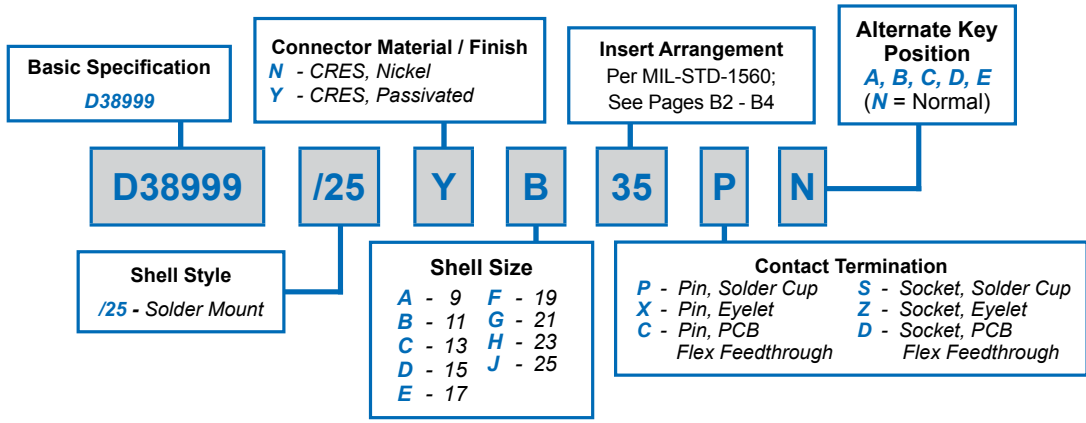

D38999/25 Solder Mount Hermetic Receptacle MIL-DTL-38999 Series III



D38999 QPL
Hermetics

How To Order: Commercial

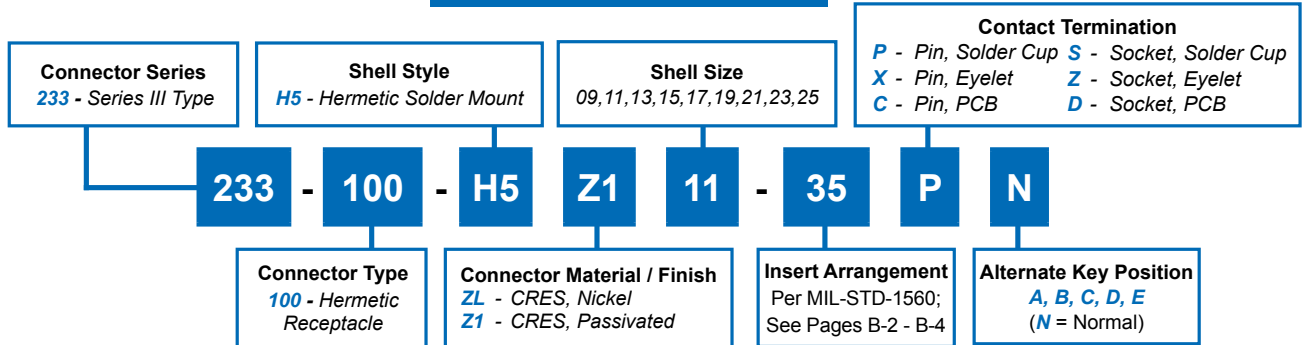

B

TABLE I: CONNECTOR DIMENSIONS

SHELL SIZE CODE	SHELL SIZE	A THREAD	ø B MAX	ø C MAX	ø D ±.005(0.1)	E MAX	F MAX	HP MAX	HS MAX
A	9/09	.6250-.1P-.3L-TS-2A	.673(17.1)	.764(19.4)	.680(17.3)	.201(5.1)	.937(23.8)	.677(17.2)	.764(19.4)
B	11	.7500-.1P-.3L-TS-2A	.783(19.9)	.858(21.8)	.789(20.0)	.201(5.1)	.937(23.8)	.677(17.2)	.764(19.4)
C	13	.8750-.1P-.3L-TS-2A	.909(23.1)	.980(24.9)	.914(23.2)	.201(5.1)	.937(23.8)	.677(17.2)	.764(19.4)
D	15	1.0000-.1P-.3L-TS-2A	1.031(26.2)	1.106(28.1)	1.038(26.4)	.201(5.1)	.937(23.8)	.677(17.2)	.764(19.4)
E	17	1.1875-.1P-.3L-TS-2A	1.157(29.4)	1.232(31.3)	1.164(29.6)	.201(5.1)	.937(23.8)	.677(17.2)	.764(19.4)
F	19	1.2500-.1P-.3L-TS-2A	1.252(31.8)	1.323(33.6)	1.258(32.0)	.201(5.1)	.937(23.8)	.677(17.2)	.764(19.4)
G	21	1.3750-.1P-.3L-TS-2A	1.378(35.0)	1.449(36.8)	1.383(35.1)	.201(5.1)	.937(23.8)	.677(17.2)	.764(19.4)
H	23	1.5000-.1P-.3L-TS-2A	1.504(38.2)	1.575(40.0)	1.508(38.3)	.232(5.9)	.969(24.6)	.677(17.2)	.764(19.4)
J	25	1.6250-.1P-.3L-TS-2A	1.626(41.3)	1.701(43.2)	1.643(41.7)	.232(5.9)	.969(24.6)	.677(17.2)	.764(19.4)

TABLE II: CONTACT SIZE

PRINTED CIRCUIT TAIL CONFIGURATIONS
CONTACT STYLE C AND D

Contact Size	ø P
22D	.011 (0.28) .015 (0.38)
20	.024 (0.61) .028 (0.71)
16	.0635 (1.61) .0615 (1.56)
12	.095 (2.41) .093 (2.36)

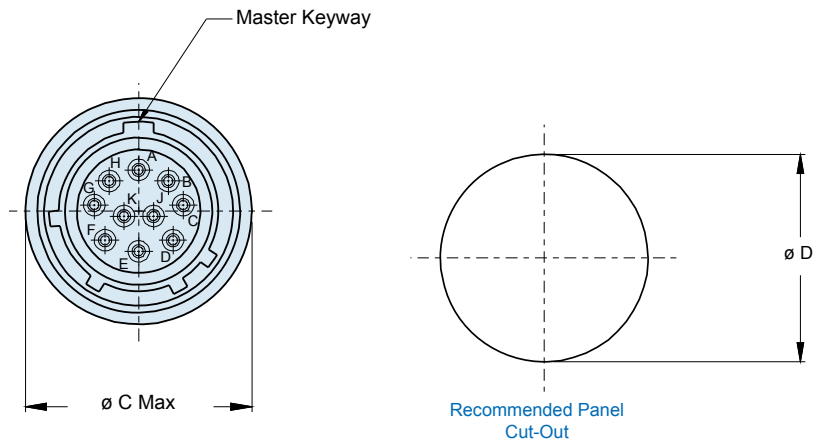

D38999/27 Weld Mount Hermetic Receptacle MIL-DTL-38999 Series III

How To Order: *MS*

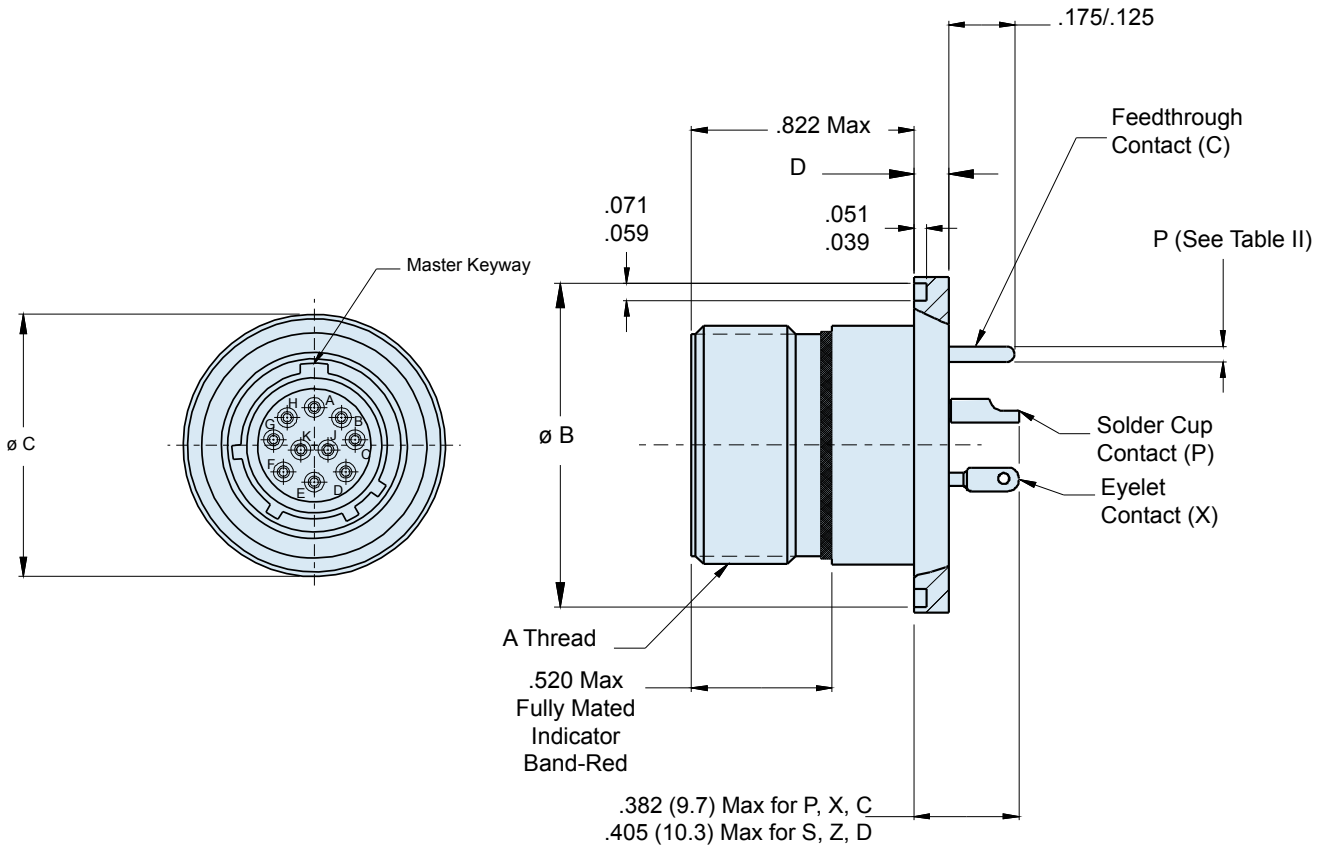
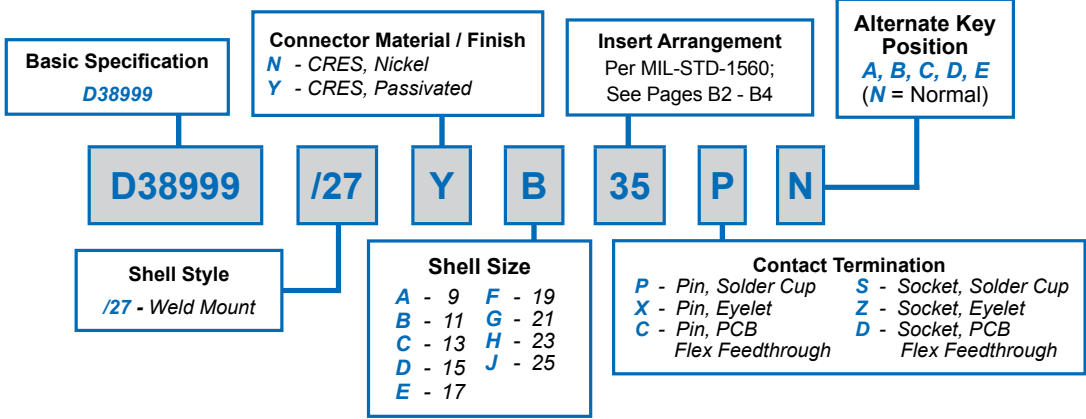

Consult Factory for Recommended Panel Cutout Dimensions

D38999/27 Weld Mount Hermetic Receptacle MIL-DTL-38999 Series III



D38999 QPL
Hermetics

How To Order: Commercial

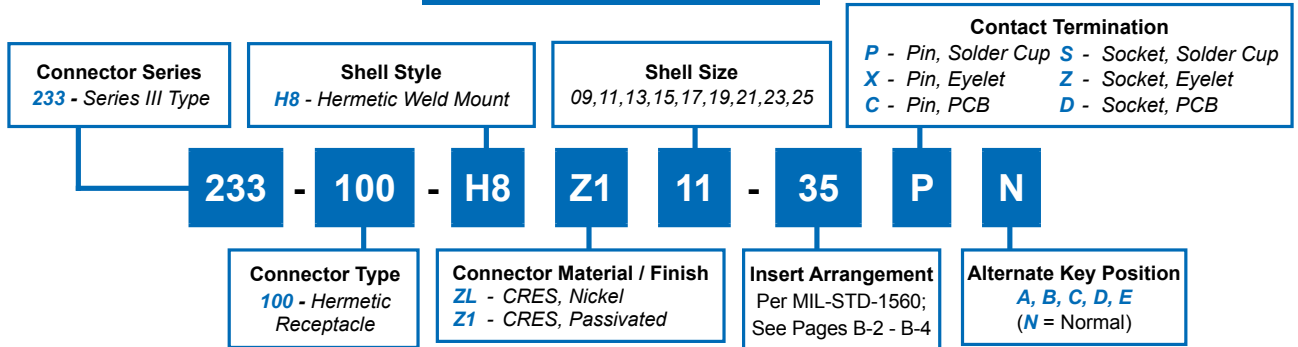

B

TABLE I: CONNECTOR DIMENSIONS

SHELL SIZE CODE	SHELL SIZE	A THREAD	Ø B	Ø C	Ø D
A	9/09	.6250-.1P-.3L-TS-2A	.941 (23.9) .929 (23.6)	.984 (25.0) .972 (24.7)	.134 (3.4) .118 (3.0)
B	11	.7500-.1P-.3L-TS-2A	1.063 (27.0) 1.051 (27.0)	1.106 (28.1) 1.094 (27.8)	.134 (3.4) .118 (3.0)
C	13	.8750-.1P-.3L-TS-2A	1.189 (30.2) 1.177 (28.9)	1.232 (31.3) 1.220 (31.0)	.134 (3.4) .118 (3.0)
D	15	1.0000-.1P-.3L-TS-2A	1.315 (33.4) 1.303 (33.1)	1.358 (34.5) 1.346 (34.2)	.134 (3.4) .118 (3.0)
E	17	1.1875-.1P-.3L-TS-2A	1.402 (35.6) 1.390 (35.3)	1.445 (36.7) 1.433 (36.4)	.134 (3.4) .118 (3.0)
F	19	1.2500-.1P-.3L-TS-2A	1.547 (39.3) 1.535 (39.0)	1.591 (40.4) 1.579 (40.1)	.134 (3.4) .118 (3.0)
G	21	1.3750-.1P-.3L-TS-2A	1.689 (42.9) 1.677 (42.6)	1.732 (44.0) 1.720 (43.7)	.134 (3.4) .118 (3.0)
H	23	1.5000-.1P-.3L-TS-2A	1.854 (47.1) 1.842 (46.8)	1.898 (48.2) 1.886 (47.4)	.165 (4.2) .149 (3.8)
J	25	1.6250-.1P-.3L-TS-2A	1.941 (49.3) 1.929 (49.0)	1.984 (50.4) 1.972 (50.1)	.165 (4.2) .149 (3.8)

TABLE II: CONTACT SIZE

PRINTED CIRCUIT TAIL CONFIGURATIONS
CONTACT STYLE C AND D

Contact Size	Ø P
22D	.011 (0.28) .015 (0.38)
20	.024 (0.61) .028 (0.71)
16	.0635 (1.61) .0615 (1.56)
12	.095 (2.41) .093 (2.36)

How To Order: MS

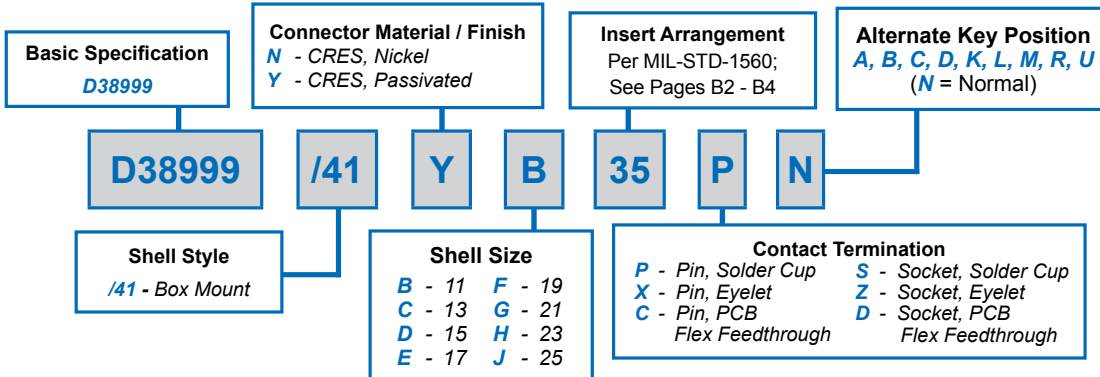
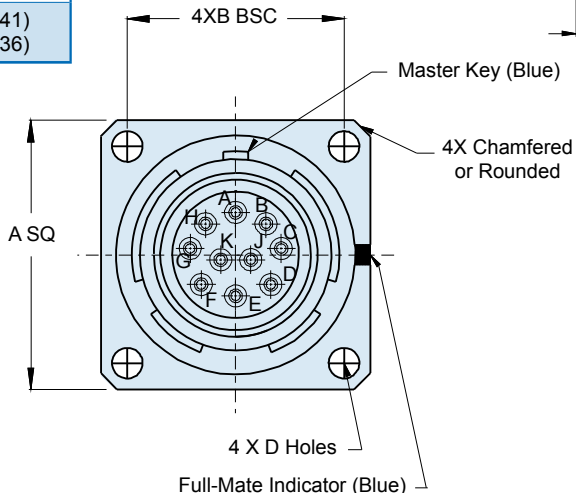
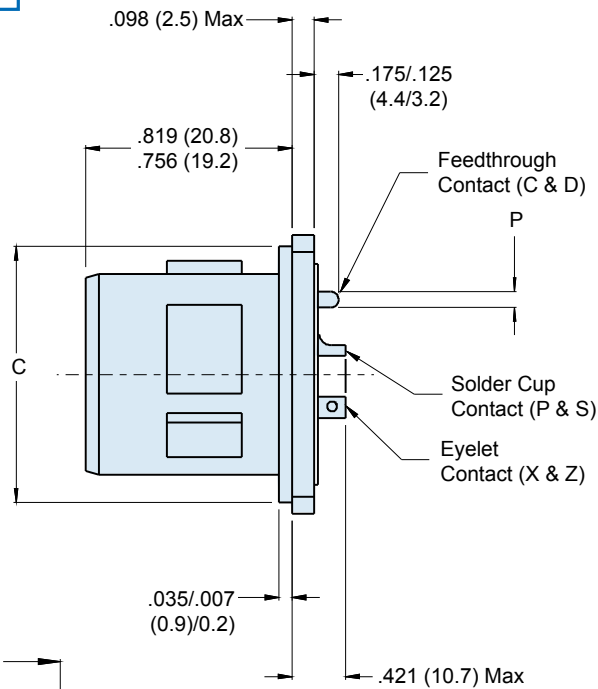

TABLE II: CONTACT SIZE

PRINTED CIRCUIT TAIL CONFIGURATIONS
CONTACT STYLE C AND D

Contact Size	ø P
22D	.011 (0.28) .015 (0.38)
20	.024 (0.61) .028 (0.71)
16	.0635 (1.61) .0615 (1.56)
12	.095 (2.41) .093 (2.36)



D38999/41 Box Mount Hermetic Receptacle MIL-DTL-38999 Series IV



D38999 QPL
Hermetics

How To Order: Commercial

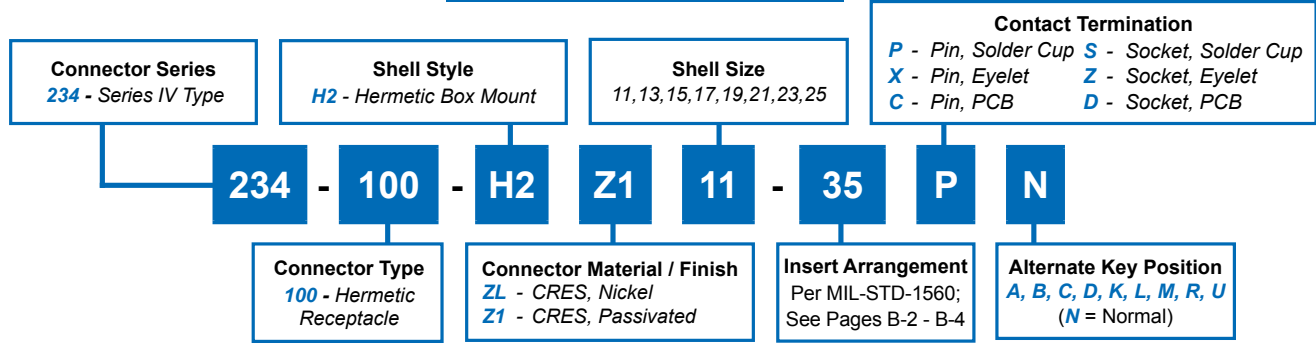

B

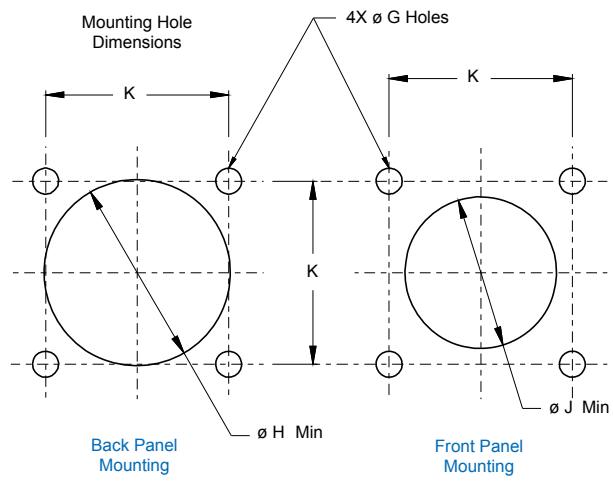
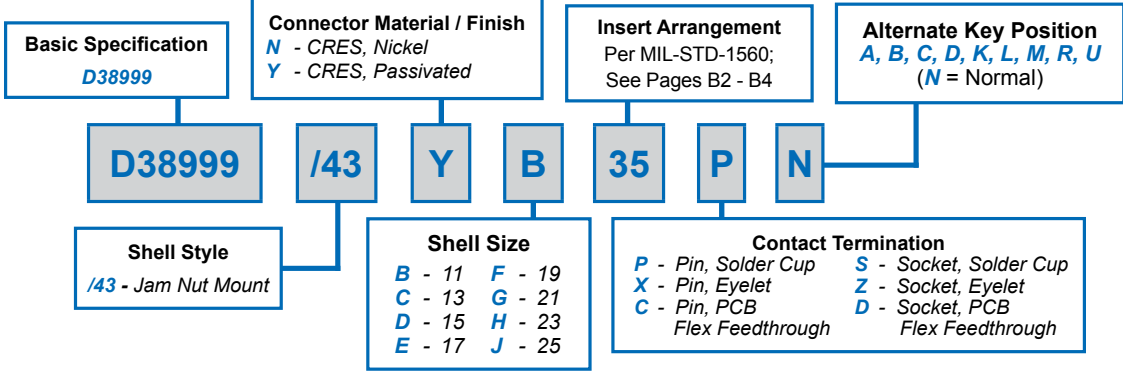

TABLE I: CONNECTOR DIMENSIONS

SHELL SIZE CODE	SHELL SIZE	A SQ	B BSC	C DIA	D DIA	øG HOLES ±.005(0.1)	ø H MIN	ø J MIN	K ±.005(0.1)
B	11	1.051(26.7) 1.008(25.6)	.812(20.6)	.793(20.1) .778(19.8)	.138(3.5) .122(3.1)	.128(3.3)	.781(19.8)	.625(15.9)	.812(20.6)
C	13	1.145(29.1) 1.102(28.0)	.906(23.0)	.919(23.3) .904(23.0)	.138(3.5) .122(3.1)	.128(3.3)	.921(23.4)	.750(19.1)	.906(23.0)
D	15	1.240(31.5) 1.197(30.4)	.969(24.6)	1.044(26.5) 1.029(26.1)	.138(3.5) .122(3.1)	.128(3.3)	1.047(26.6)	.906(23.0)	.968(24.6)
E	17	1.334(33.9) 1.291(32.8)	1.062(27.0)	1.170(29.7) 1.155(29.3)	.138(3.5) .122(3.1)	.128(3.3)	1.218(30.9)	1.016(25.8)	1.062(27.0)
F	19	1.460(37.1) 1.417(36.0)	1.156(29.4)	1.294(32.9) 1.279(32.5)	.138(3.5) .122(3.1)	.128(3.3)	1.296(32.9)	1.142(29.0)	1.156(29.4)
G	21	1.583(40.2) 1.539(39.1)	1.250(31.8)	1.419(36.0) 1.404(35.7)	.138(3.5) .122(3.1)	.128(3.3)	1.421(36.1)	1.266(32.2)	1.250(31.8)
H	23	1.709(43.4) 1.665(42.3)	1.375(34.9)	1.544(39.2) 1.529(38.8)	.157(4.0) .142(3.6)	.154(3.9)	1.546(39.3)	1.375(34.9)	1.375(34.9)
J	25	1.835(46.6) 1.791(45.5)	1.500(38.1)	1.670(42.4) 1.654(42.0)	.157(4.0) .142(3.6)	.154(3.9)	1.672(42.5)	1.484(37.7)	1.500(38.1)

D38999/43 Jam Nut Mount Hermetic Receptacle MIL-DTL-38999 Series IV

How To Order: *MS*



B

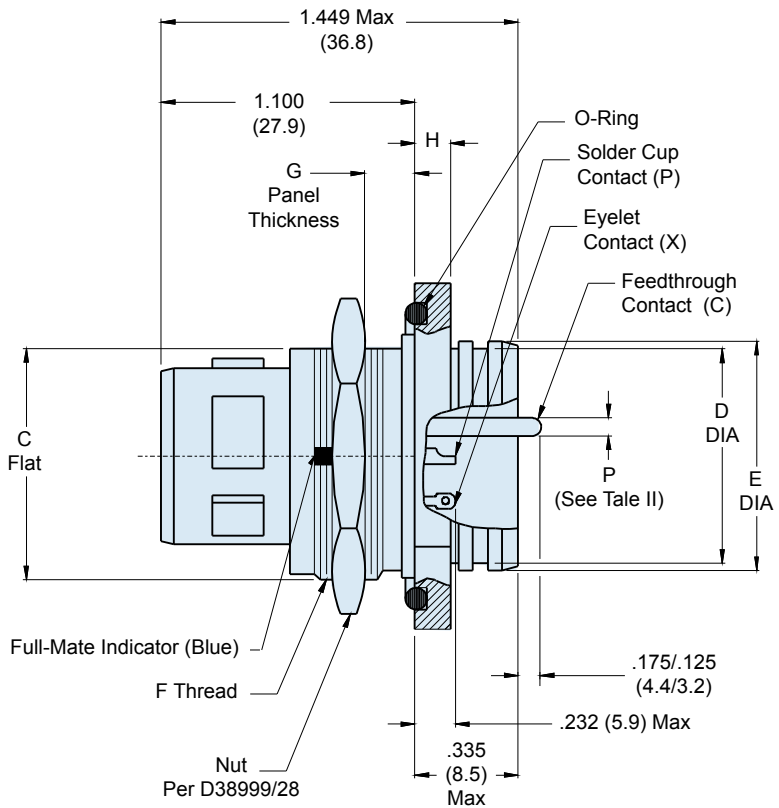
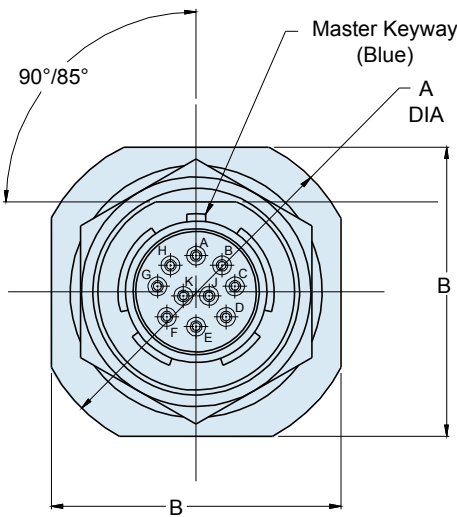

D38999/43 Jam Nut Mount Hermetic Receptacle MIL-DTL-38999 Series IV



D38999 QPL
Hermetics

How To Order: Commercial

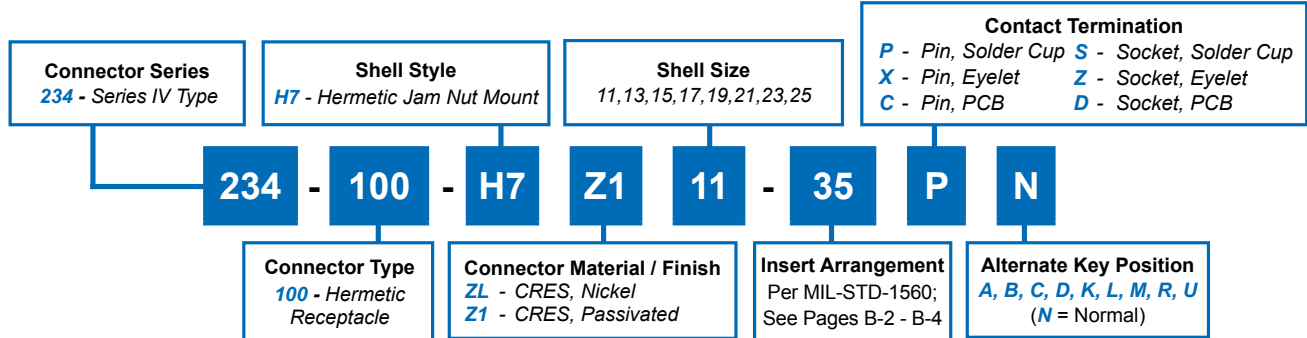

B

TABLE I: CONNECTOR DIMENSIONS

SHELL SIZE CODE	SHELL SIZE	A DIA	B FLATS ±.018(0.5)	C FLAT	D DIA	E DIA ±.010(0.3)	F THREAD ISO METRIC	G ±.033(0.8)	H ±.012(0.3)
B	11	1.385(35.2) 1.362(34.6)	1.250(31.8)	.754(19.2) .745(18.9)	.733(18.6) .716(18.2)	.769(19.5)	M20 X 1.0-6g	.092(2.3)	.106(2.7)
C	13	1.511(38.4) 1.488(37.8)	1.376(35.0)	.941(23.9) .932(23.7)	.858(21.8) .839(21.3)	.899(22.8)	M25 X 1.0-6g	.092(2.3)	.106(2.7)
D	15	1.637(41.6) 1.614(41.0)	1.502(38.2)	1.065(27.1) 1.056(26.8)	.984(25.0) .968(24.6)	1.025(26.0)	M28 X 1.0-6g	.092(2.3)	.106(2.7)
E	17	1.763(44.8) 1.740(44.2)	1.624(41.2)	1.190(30.2) 1.181(30.0)	1.110(28.2) 1.091(27.7)	1.147(29.1)	M32 X 1.0-6g	.092(2.3)	.106(2.7)
F	19	1.948(49.5) 1.925(48.9)	1.813(46.1)	1.316(33.4) 1.306(33.2)	1.236(31.4) 1.220(31.0)	1.273(32.3)	M35 X 1.0-6g	.092(2.3)	.137(3.5)
G	21	2.074(52.7) 2.051(52.1)	1.939(49.3)	1.441(36.6) 1.431(36.3)	1.358(34.5) 1.342(34.1)	1.399(35.5)	M38 X 1.0-6g	.092(2.3)	.137(3.5)
H	23	2.200(55.9) 2.177(55.3)	2.061(52.3)	1.565(39.8) 1.556(39.5)	1.484(37.7) 1.468(37.3)	1.525(38.7)	M41 X 1.0-6g	.092(2.3)	.137(3.5)
J	25	2.326(59.1) 2.299(58.4)	2.187(55.5)	1.692(43.0) 1.681(42.7)	1.610(40.9) 1.594(40.5)	1.647(41.8)	M44 X 1.0-6g	.092(2.3)	.137(3.5)

TABLE I (CONTINUED):
CUT-OUT DIMENSIONS

SHELL SIZE CODE	J DIA	K
B	.835 (21.21) .825 (20.96)	.771 (19.58) .761 (19.33)
C	1.020 (25.91) 1.010 (25.65)	.955 (24.26) .945 (24.00)
D	1.145 (29.08) 1.133 (28.78)	1.085 (27.56) 1.075 (27.31)
E	1.270 (32.26) 1.260 (32.00)	1.210 (30.73) 1.200 (30.48)
F	1.395 (35.43) 1.385 (35.18)	1.335 (33.91) 1.325 (33.66)
G	1.520 (38.61) 1.510 (38.35)	1.460 (37.08) 1.450 (36.83)
H	1.645 (41.78) 1.635 (41.53)	1.585 (40.26) 1.575 (40.01)
J	1.770 (44.96) 1.760 (44.70)	1.710 (43.43) 1.700 (43.18)

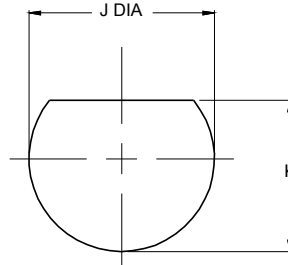

Recommended Panel
Cut-Out

TABLE II: CONTACT SIZE

PRINTED CIRCUIT TAIL CONFIGURATIONS
CONTACT STYLE C AND D

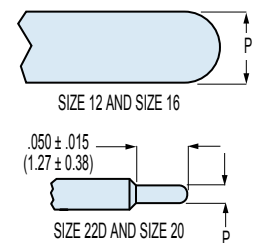

Contact Size	ø P
22D	.011 (0.28) .015 (0.38)
20	.024 (0.61) .028 (0.71)
16	.0635 (1.61) .0615 (1.56)
12	.095 (2.41) .093 (2.36)

How To Order: *MS*

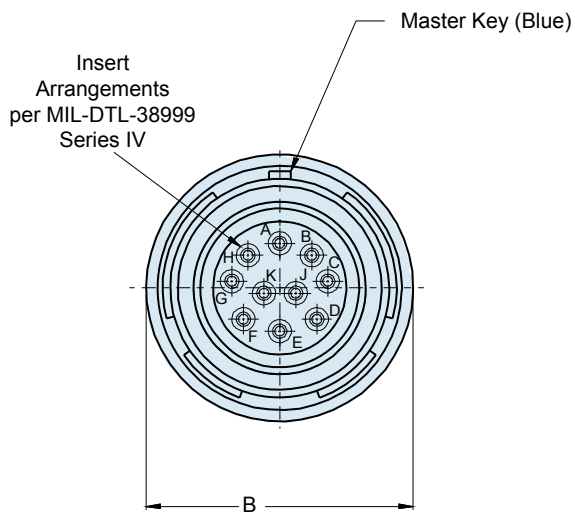
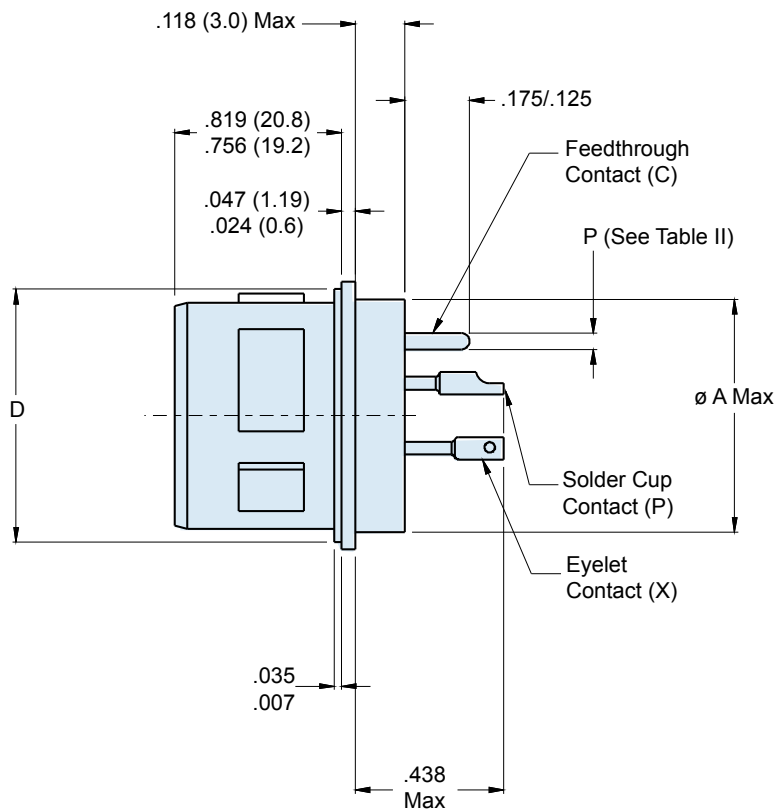
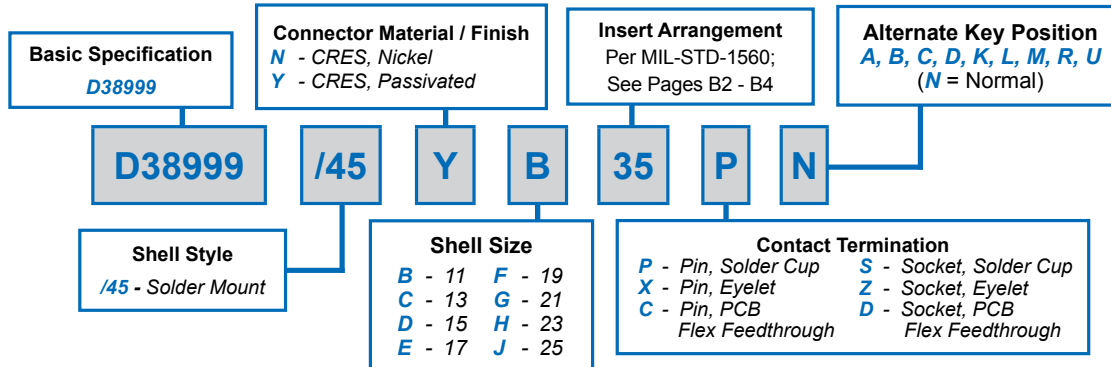

D38999/45 Solder Mount Hermetic Receptacle MIL-DTL-38999 Series IV



D38999 QPL
Hermetics

How To Order: Commercial

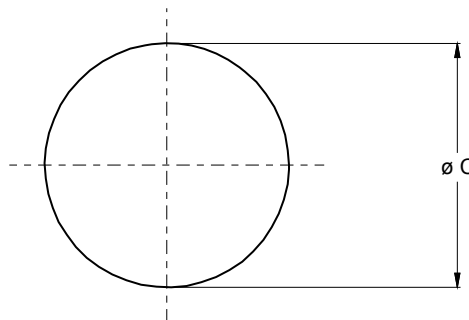
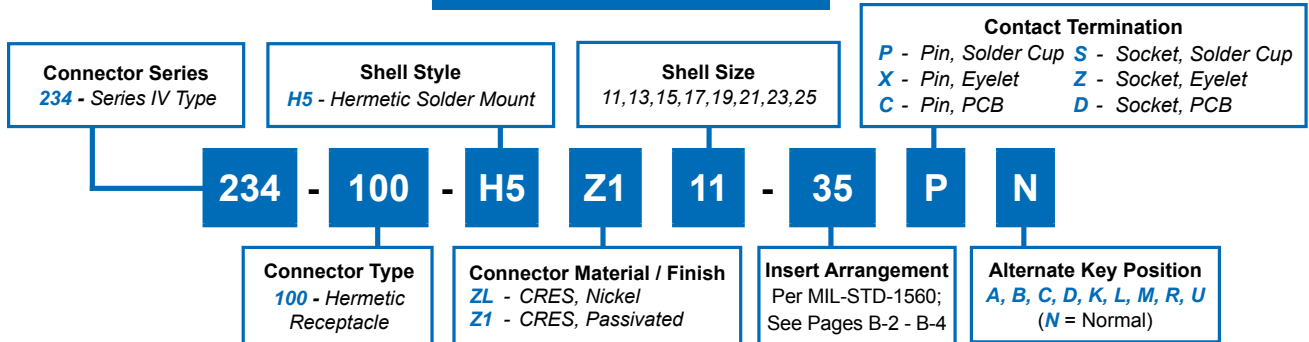

Recommended Panel
Cut-Out

TABLE I: CONNECTOR DIMENSIONS

SHELL SIZE CODE	SHELL SIZE	Ø A MAX	Ø B MAX	Ø C ±.005(0.1)	D
B	11	.783(19.9)	.862(21.9)	.789(20.0)	.793(20.1) .778(19.8)
C	13	.909(23.1)	.988(25.1)	.914(23.2)	.919(23.3) .904(23.0)
D	15	1.035(26.3)	1.110(28.2)	1.038(26.4)	1.044(26.5) 1.028(26.1)
E	17	1.157(29.4)	1.236(31.4)	1.164(29.6)	1.170(29.7) 1.155(29.3)
F	19	1.252(31.8)	1.331(33.8)	1.258(32.0)	1.294(32.9) 1.279(32.5)
G	21	1.378(35.0)	1.457(37.0)	1.383(35.1)	1.419(36.0) 1.404(35.7)
H	23	1.504(38.2)	1.583(40.2)	1.508(38.3)	1.544(39.2) 1.528(38.8)
J	25	1.630(41.4)	1.705(43.3)	1.643(41.7)	1.670(42.4) 1.654(42.0)

TABLE II: CONTACT SIZE

PRINTED CIRCUIT TAIL CONFIGURATIONS
CONTACT STYLE C AND D

Contact Size	Ø P
22D	.011 (0.28) .015 (0.38)
20	.024 (0.61) .028 (0.71)
16	.0635 (1.61) .0615 (1.56)
12	.095 (2.41) .093 (2.36)



D38999/48 Weld Mount Hermetic Receptacle MIL-DTL-38999 Series IV

How To Order: MS

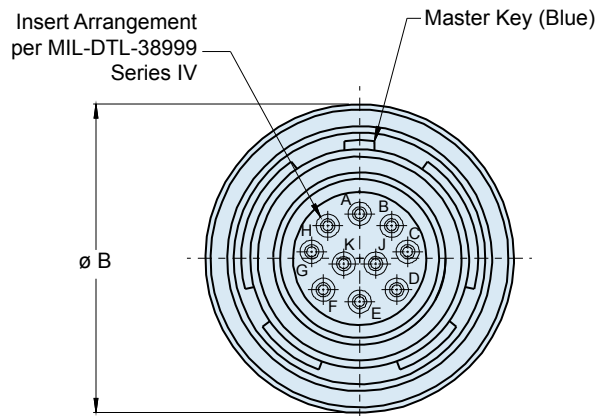
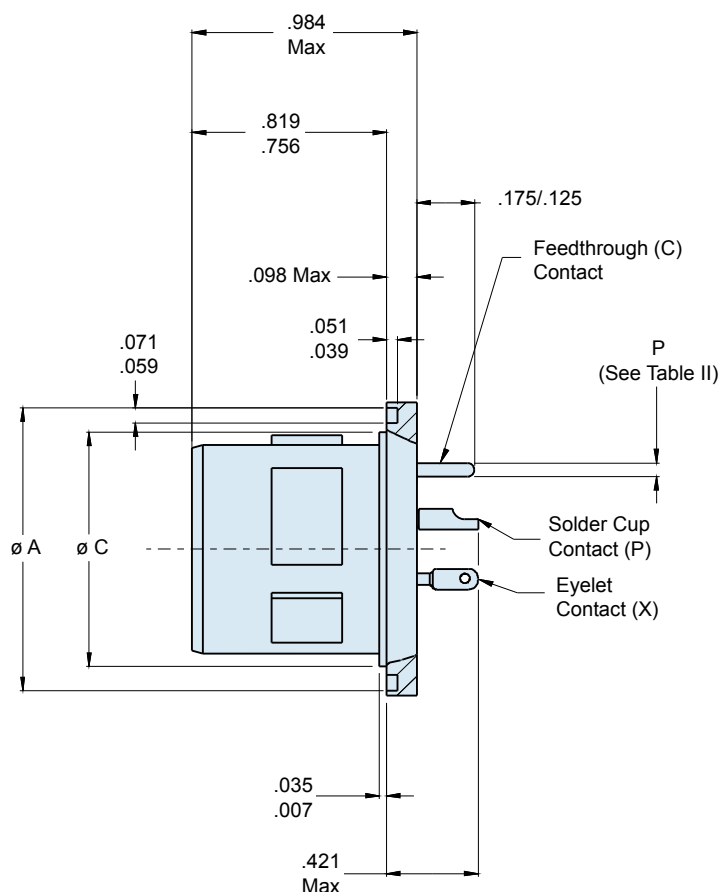
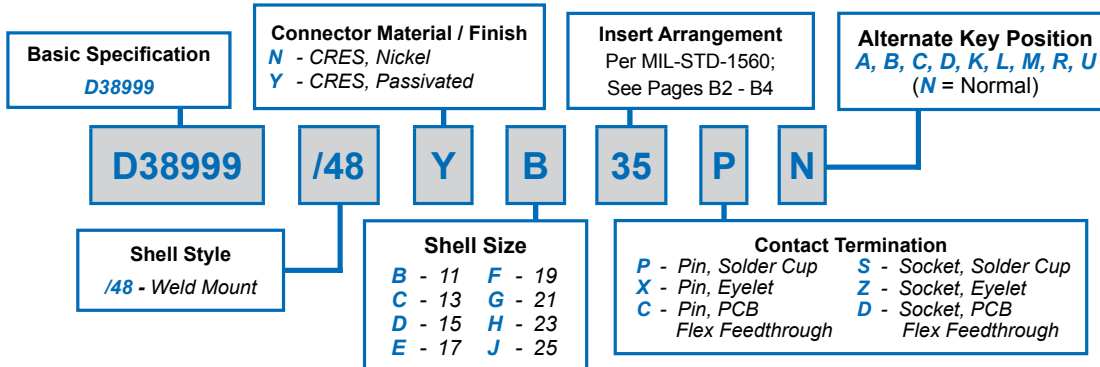

Consult Factory for Recommended Panel Cutout Dimensions

D38999/48 Weld Mount Hermetic Receptacle MIL-DTL-38999 Series IV



D38999 QPL
Hermetics

How To Order: Commercial

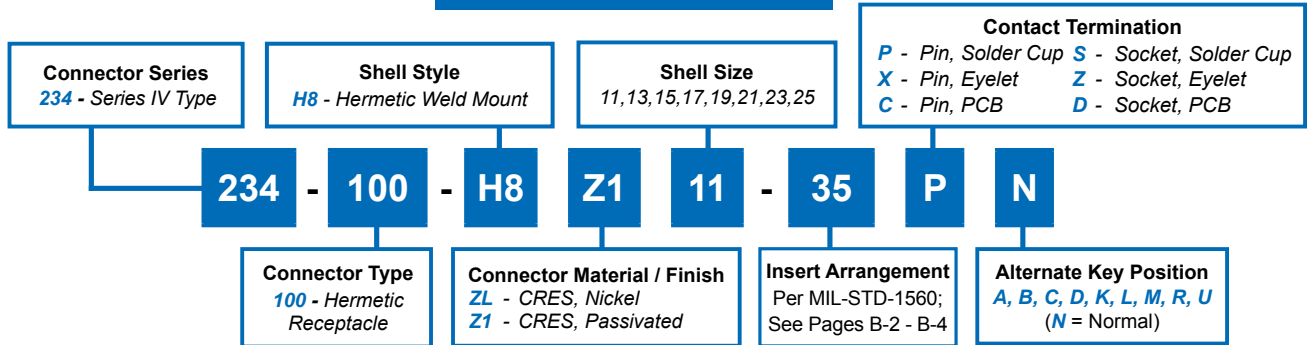

B

SHELL SIZE CODE	SHELL SIZE	ø A	ø B	ø C
B	11	1.035 (26.3) 1.024 (26.0)	1.106 (28.1) 1.094 (27.8)	.793 (20.1) .778 (19.8)
C	13	1.161 (29.5) 1.150 (29.2)	1.232 (31.3) 1.220 (31.0)	.919 (23.3) .904 (23.0)
D	15	1.287 (32.7) 1.276 (32.4)	1.358 (34.5) 1.346 (34.2)	1.044 (26.5) 1.029 (26.1)
E	17	1.374 (34.9) 1.362 (34.6)	1.445 (36.7) 1.433 (36.4)	1.170 (29.7) 1.155 (29.3)
F	19	1.520 (38.6) 1.508 (38.3)	1.591 (40.4) 1.579 (40.1)	1.294 (32.9) 1.279 (32.5)
G	21	1.661 (42.2) 1.650 (41.9)	1.732 (44.0) 1.720 (43.7)	1.419 (36.0) 1.404 (35.7)
H	23	1.827 (46.4) 1.815 (46.1)	1.898 (48.2) 1.886 (47.4)	1.544 (39.2) 1.529 (38.8)
J	25	1.913 (48.6) 1.902 (48.3)	1.984 (50.4) 1.972 (50.1)	1.669 (42.4) 1.654 (42.0)

Contact Size	ø P
22D	.011 (0.28) .015 (0.38)
20	.024 (0.61) .028 (0.71)
16	.0635 (1.61) .0615 (1.56)
12	.095 (2.41) .093 (2.36)

PRINTED CIRCUIT TAIL CONFIGURATIONS
CONTACT STYLE C AND D

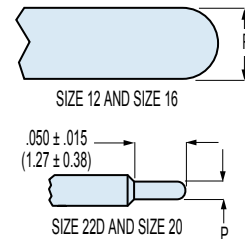



257-333
Hermetic Jam Nut Receptacle
with Crimp Removable Socket Contacts
MIL-DTL-38999 Series III Type

B

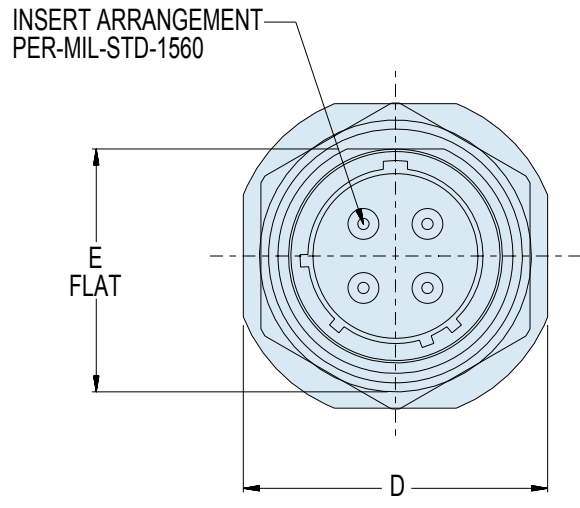
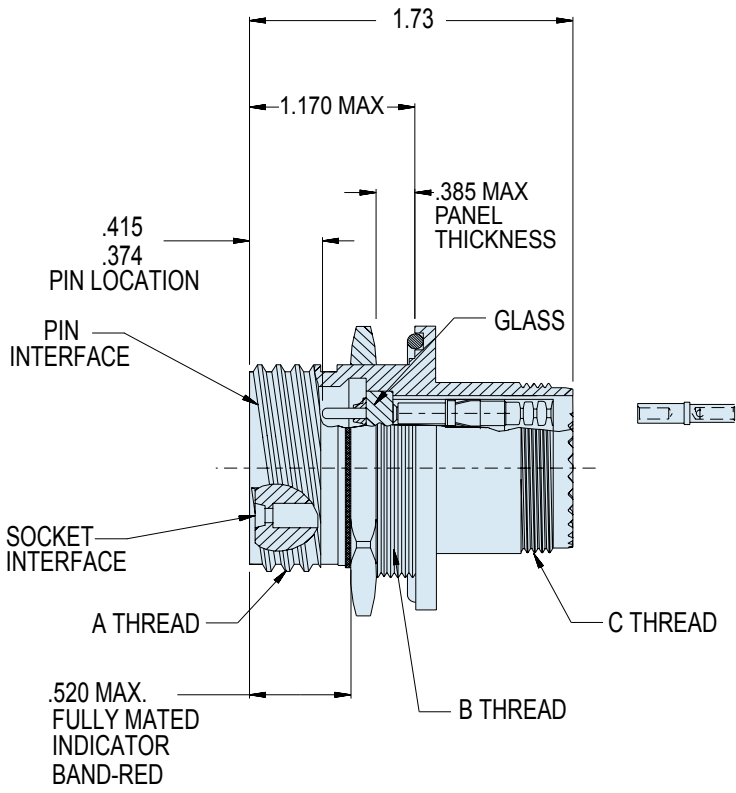
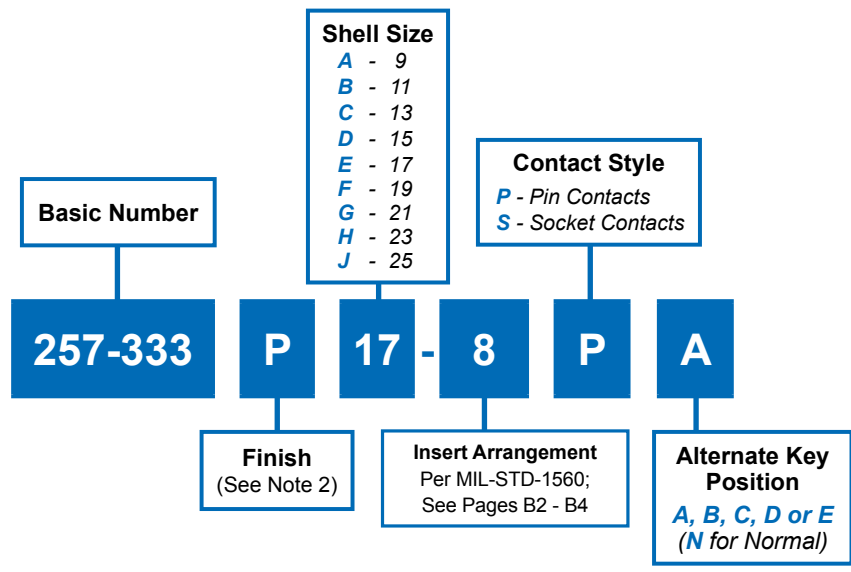

257-333
Hermetic Jam Nut Receptacle
with Crimp Removable Socket Contacts
MIL-DTL-38999 Series III Type



D38999 QPL
 Hermetics

TABLE I (CONTINUED):
CUT-OUT DIMENSIONS

SHELL SIZE	K DIA ± .005 (0.1)	N ± .005 (0.1)
A	.693 (17.60)	.657 (16.70)
B	.825 (20.96)	.771 (19.59)
C	1.010 (25.65)	.955 (24.26)
D	1.135 (28.83)	1.085 (27.56)
E	1.260 (32.01)	1.210 (30.73)
F	1.385 (35.18)	1.335 (33.91)
G	1.510 (38.35)	1.460 (37.08)
H	1.635 (41.53)	1.585 (40.26)
J	1.760 (44.70)	1.710 (43.43)

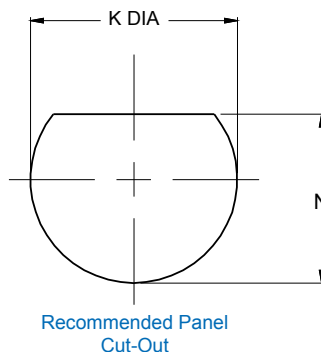

B

TABLE I: CONNECTOR DIMENSIONS

SHELL SIZE	SHELL SIZE CODE	A THREAD	B THREAD	C THREAD	D +/- .016 (MM)	E +/- .004-.006 (MM)
9	A	.6250-.1P.3L-TS-2A	M17x1-6g 0.100R	M12x1-6g 0.100R	1.062 (2.70)	0.651 (1.65)
11	B	.7500-.1P.3L-TS-2A	M20x1-6g 0.100R	M15x1-6g 0.100R	1.252 (3.18)	0.751 (1.91)
13	C	.8750-.1P.3L-TS-2A	M25x1-6g 0.100R	M18x1-6g 0.100R	1.374 (3.49)	0.938 (2.38)
15	D	1.000-.1P.3L-TS-2A	M28x1-6g 0.100R	M22x1-6g 0.100R	1.500 (3.81)	1.062 (2.70)
17	E	1.1875-.1P.3L-TS-2A	M32x1-6g 0.100R	M25x1-6g 0.100R	1.626 (4.13)	1.187 (3.01)
19	F	1.250-.1P.3L-TS-2A	M35x1-6g 0.100R	M28x1-6g 0.100R	1.811 (4.60)	1.312 (3.33)
21	G	1.375-.1P.3L-TS-2A	M38x1-6g 0.100R	M31x1-6g 0.100R	1.937 (4.92)	1.437 (3.65)
23	H	1.500-.1P.3L-TS-2A	M41x1-6g 0.100R	M34x1-6g 0.100R	2.063 (5.24)	1.562 (3.97)
25	J	1.625-.1P.3L-TS-2A	M44x1-6g 0.100R	M37x1-6g 0.100R	2.189 (5.56)	1.687 (4.28)

APPLICATION NOTES

- Assembly to be identified with Glenair's name and part number and date code, space permitting.
- Material/finishes:
 Shell Receptacle, Jam Nut – CRES Passivated (Z1), CRES/NI (P)
 Pin Contact – alloy 52 / gold plated
 Socket Contact – copper alloy / gold plated
 Insulator – fused vitreous glass / N.A.
 Insulators – high grade rigid dielectric
 Seals—fluorosilicone / N.A.
- Crimp removable socket contacts to conform to:
 MIL-C-39029/57-358 – size 16;
 MIL-C-39029/57-357 – size 20;
 and MIL-C-39029/57-354 – size 22D (supplied loose)
 Supply 1 extra contact for each size used.

Glenair MIL-DTL-38999 Type Filter Connectors

SECTION C TABLE OF CONTENTS

GLENAIR MIL-DTL-38999 TYPE FILTER CONNECTORS:

Glenair MIL-DTL-38999 Type Filter Connector Product Features.....	C-1
MIL-DTL-38999 Series I Type Master How-to-Order and Reference Information.....	C-2
240-381W Series I Type Wall Mount Filter Connector w/ Accessory Threads.....	C-4
240-381R Series I Type Wall Mount Filter Connector w/ Crimp Removable Contacts.....	C-6
240-381J Series I Type Jam Nut Mount Filter Connector.....	C-8
240-381A Series I Type Sav-Con® Filtered Connector Adapter.....	C-10
MIL-DTL-38999 Series II Type Master How-to-Order and Reference Information.....	C-12
240-382W Series II Type Wall Mount Filter Connector.....	C-14
240-382J Series II Type Jam Nut Filter Connector.....	C-16
240-382A Series II Type Sav-Con® Filtered Connector Adapter.....	C-18
MIL-DTL-38999 Series III Type Master How-to-Order and Reference Information.....	C-20
240-383P Series III Type Filter Connector Plug.....	C-22
240-383W Series III Type Wall Mount Filter Connector.....	C-24
240-383J Series III Type Jam Nut Filter Connector.....	C-26
240-383S Series III Type Jam Nut Filter Connector w/ Crimp Removable Contacts.....	C-28
240-383D Series III Type Dual Flange Wall Mount w/ PC Tails.....	C-30
240-383E Series III Type Dual Flange Jam Nut Filter Connector.....	C-32
240-383R Series III Type Wall Mount Filter Connector w/ Crimp Removable Contacts.....	C-34
240-383A Series III Type Sav-Con® Filtered Connector Adapter.....	C-36
MIL-DTL-38999 Series IV Type Master How-to-Order and Reference Information.....	C-38
240-384J Series IV Type Jam Nut Filter Connector.....	C-40
240-384W Series IV Type Wall Mount Filter Connector.....	C-42

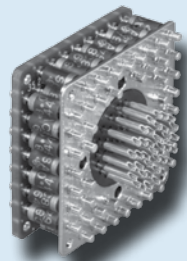
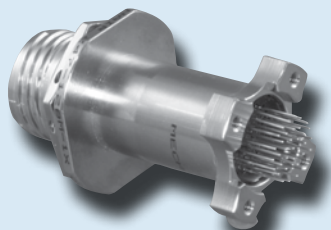



PRODUCT FEATURES

- All Filter Connector Styles Meet or Exceed Applicable Military Standards
- C and Pi Circuit Filters from 400 pF to 240,000 pF
- All Connector Series are Intermateable with Standard (Non-Filtered) Plugs and Connector Adapters
- Broadest Range of Insert Arrangements for MIL-DTL-38999 Series I, II, III and IV
- PC Tail, Solder Cup and Crimp-Contact Versions
- Space-Grade Bake-Out Processing Available
- Transient Voltage Suppression Diodes Available

The Industry's Best Short Lead-Time Source for Planar Array Type EMI/EMP Filter Connectors

C

Military Standard Type Series

Glenair's family of circular military standard type EMI/EMP filter connectors is designed to meet stringent military/aerospace performance requirements. Each connector series is offered with standard low-pass Pi or C filter arrays, or with customized filters to meet specific frequency and capacitance requirements. Thermally conductive epoxy protects the filter package from mechanical and heat stress and also provides a waterproof seal. All filtered receptacles are intermateable with standard plugs and connector savers, and each respective series of connectors is supplied with a range of shell styles in both environmental and hermetic configurations. Please see the "How to Order" page for available styles for each series:

MIL-DTL-38999 Series I.....	C-2	MIL-DTL-38999 Series III.....	C-20
MIL-DTL-38999 Series II.....	C-12	MIL-DTL-38999 Series IV.....	C-38

MATERIAL AND FINISHES

Contacts	Beryllium Copper Alloy, 50 μ Inch Gold Plated per ASTM B488 Type 3, Code C, Class 1,27 over Nickel Underplate per QQ-N-290 Class 2. Socket Contact Hood: Corrosion Resistant Steel, Passivated.
Insulator	Liquid crystal Polymer (LCP) per MIL-M-24519 GLP-30F, 30% Glass-Filled
Interfacial Seal, O-Ring, and Peripheral Seal	Flourosilicone Elastomer per A-A-59588, Color Blue
Shell, Jam Nut Material	Aluminum Alloy per ASTM B 211 or ASTM B 221 or Corrosion Resistant Steel per AMS-QQ-S-763
Shell and Jam Nut Finish	Code M: Electroless Nickel per AMS-C-26074 (96 Hour Salt Spray) Code NF: Olive Drab Cadmium per AMS-QQ-P-416 over Electroless Nickel (500 Hour Salt Spray) Code P: Stainless Steel with Electro-Deposited Nickel Code MT: Ni-PTFE 1000 Hour Grey™ (Nickel Flourocarbon Polymer) per MIL-DTL-38999 Rev. L
Potting Compound	Thermally Conductive Epoxy



**Glenair MIL-DTL-38999 Series I Type
Scoop-Proof Filter Connector with Bayonet Coupling
Master How to Order • Part Number Breakdown**

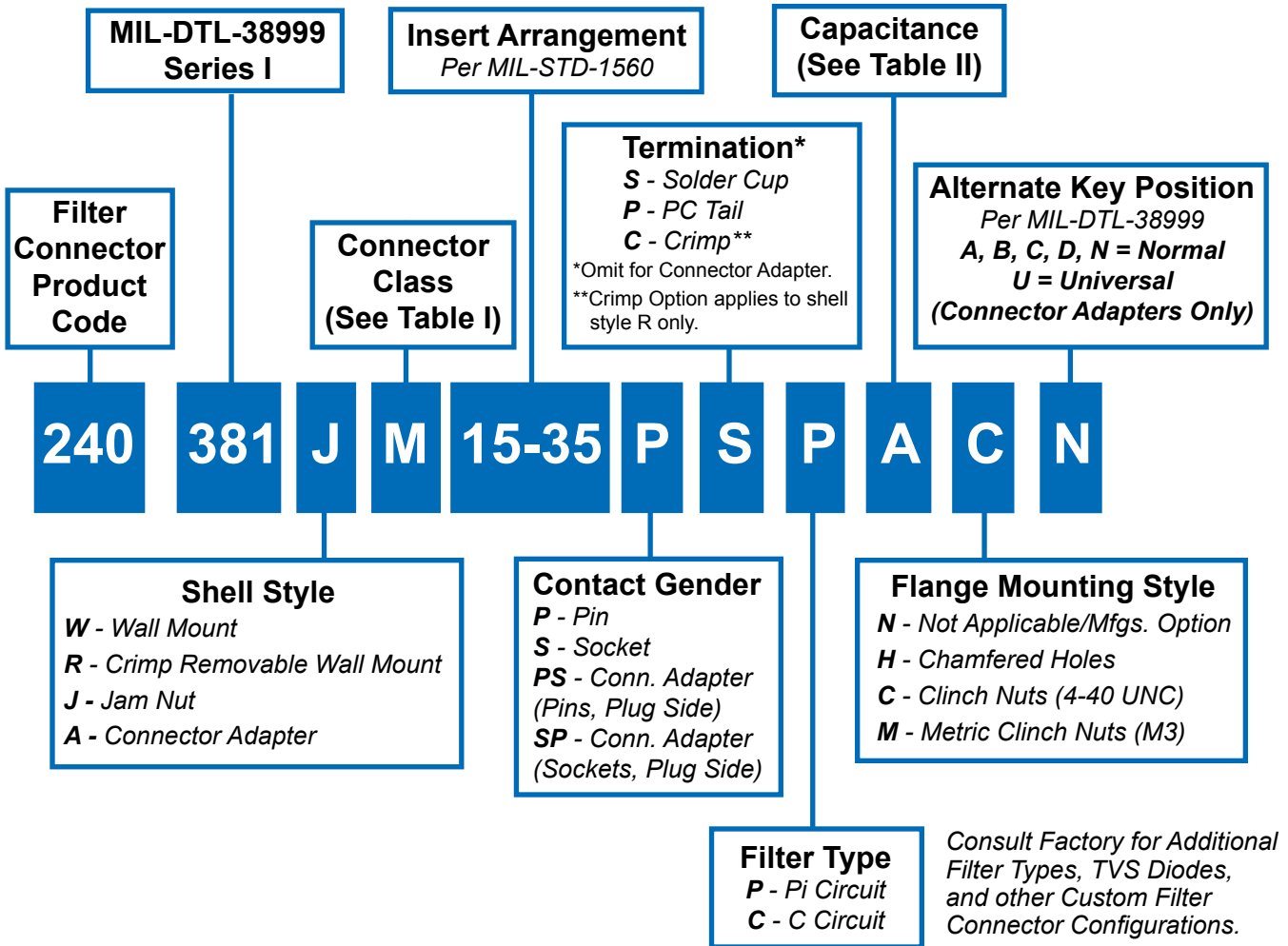

TABLE I: CONNECTOR CLASS

SYM	CLASS	MATERIAL	FINISH DESCRIPTION
M	Environmental	Aluminum	Electroless Nickel
MT	Environmental	Aluminum	Ni-PTFE 1000 Hour Grey™ Nickel Fluorocarbon Polymer
NF	Environmental	Aluminum	Cadmium O.D. Over Electroless Nickel
P	Environmental	Stainless Steel	Electro-Deposited Nickel
ZN	Environmental	Aluminum	Zinc-Nickel Over Electroless Nickel

TABLE II: CAPACITOR ARRAY CODE CAPACITANCE RANGE

CLASS	PI - CIRCUIT (pF)	C - CIRCUIT (pF)
X*	160,000 - 240,000	80,000 - 120,000
Y*	80,000 - 120,000	40,000 - 60,000
Z*	60,000 - 90,000	30,000 - 45,000
A	38,000 - 56,000	19,000 - 28,000
B	32,000 - 45,000	16,000 - 22,500
C	18,000 - 33,000	9,000 - 16,500
D	8,000 - 12,000	4,000 - 6,000
E	3,300 - 5,000	1,650 - 2,500
F	800 - 1,300	400 - 650
G	400 - 600	200 - 300

* Reduced DWV – Please consult factory.

Glenair MIL-DTL-38999 Series I Type Scoop-Proof Filter Connector with Bayonet Coupling Reference Information



EMI/EMP
Filters

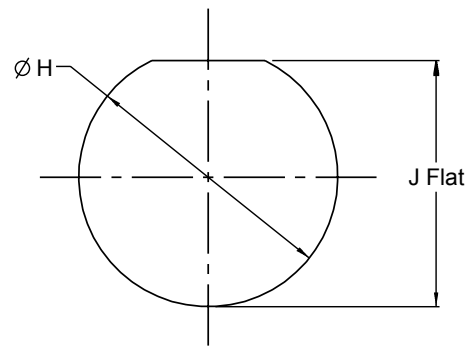
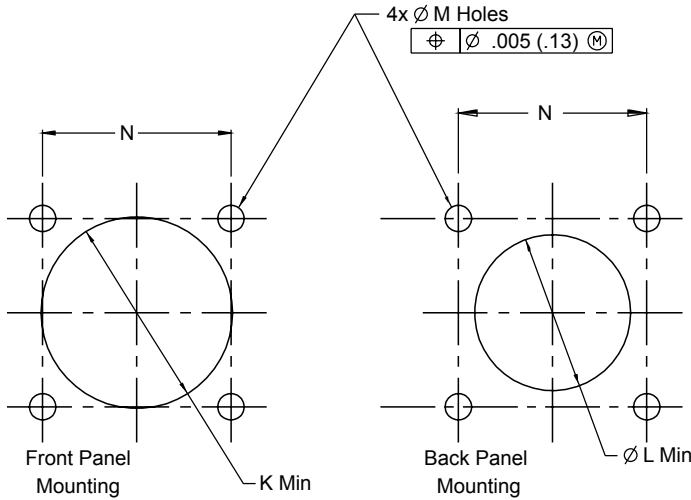

MIL-DTL-38999 Series I Square Flange Panel Cutouts					
Shell Size Code	Shell Size	Ø K Min	Ø L Min	M Holes	N BSC
A	09	.656 (16.7)	.516 (13.1)	.133 (3.4) .123 (3.1)	.719 (18.3)
B	11	.796 (20.2)	.625 (15.9)	.133 (3.4) .123 (3.1)	.812 (20.6)
C	13	.922 (23.4)	.750 (19.1)	.133 (3.4) .123 (3.1)	.906 (23.0)
D	15	1.047 (26.6)	.906 (23.0)	.133 (3.4) .123 (3.1)	.969 (24.6)
E	17	1.219 (31.0)	1.016 (25.8)	.133 (3.4) .123 (3.1)	1.062 (27.0)
F	19	1.297 (32.9)	1.141 (29.0)	.133 (3.4) .123 (3.1)	1.156 (29.4)
G	21	1.422 (36.1)	1.266 (32.2)	.133 (3.4) .123 (3.1)	1.250 (31.8)
H	23	1.547 (39.3)	1.375 (34.9)	.159 (4.0) .149 (3.8)	1.375 (34.9)
J	25	1.672 (42.5)	1.484 (37.7)	.155 (3.9) .145 (3.7)	1.500 (38.1)

MIL-DTL-38999 Series I Jam Nut Panel Cutout			
SHELL SIZE CODE	SHELL SIZE	Ø H	J
A	09	.710 (18.0) .700 (17.8)	.670 (17.0) .660 (16.8)
B	11	.835 (21.2) .825 (21.0)	.771 (19.6) .761 (19.3)
C	13	1.020 (25.9) 1.010 (25.7)	.955 (24.3) .945 (24.0)
D	15	1.145 (29.1) 1.135 (28.8)	1.085 (27.6) 1.075 (27.3)
E	17	1.270 (32.3) 1.260 (32.0)	1.210 (30.7) 1.200 (30.5)
F	19	1.395 (35.4) 1.385 (35.2)	1.335 (33.9) 1.325 (33.7)
G	21	1.520 (38.6) 1.510 (38.4)	1.460 (37.1) 1.450 (36.8)
H	23	1.645 (41.8) 1.635 (41.5)	1.585 (40.3) 1.575 (40.0)
J	25	1.770 (45.0) 1.760 (44.7)	1.710 (43.4) 1.700 (43.2)

APPLICATION NOTES

- Materials/Finishes: Shells, Barrel, Coupling Nut, Jam Nut - See Table I
Insulators - high grade rigid dielectric/N.A.
Seals - Fluorosilicone
PC Tail & Solder Cup contacts: 50µ" Gold over 50µ" Nickel
- Assembly to be identified with Glenair's name, part number, and date code - space permitting.
- Insert Arrangement in accordance with MIL-STD-1560.
(Arrangement shown for reference only)
- EMI Circular Filter Receptacle connector designed to meet requirements of MIL-STD-2120 and MIL-DTL-38999, Series I.
- All contacts to have identical filter value. Other filter arrangements available, contact factory.
- Electrical Ratings: DWV- 500 VDC Min.; Standard Operating Voltage 200 Volts DC; Current Rating 5 Amps (size 22);
- Insulation Resistance: 5000 MegOhms Min. at 200 VDC.
- Operating Temperature -55°C to +125°C (Env Class Connectors)
- Other filter styles (C-L, L-C, Unbalanced PI, Multi-Stage, Multi-Value) are available, please consult the factory.
- Metric Dimensions (mm) are indicated in parentheses.

C

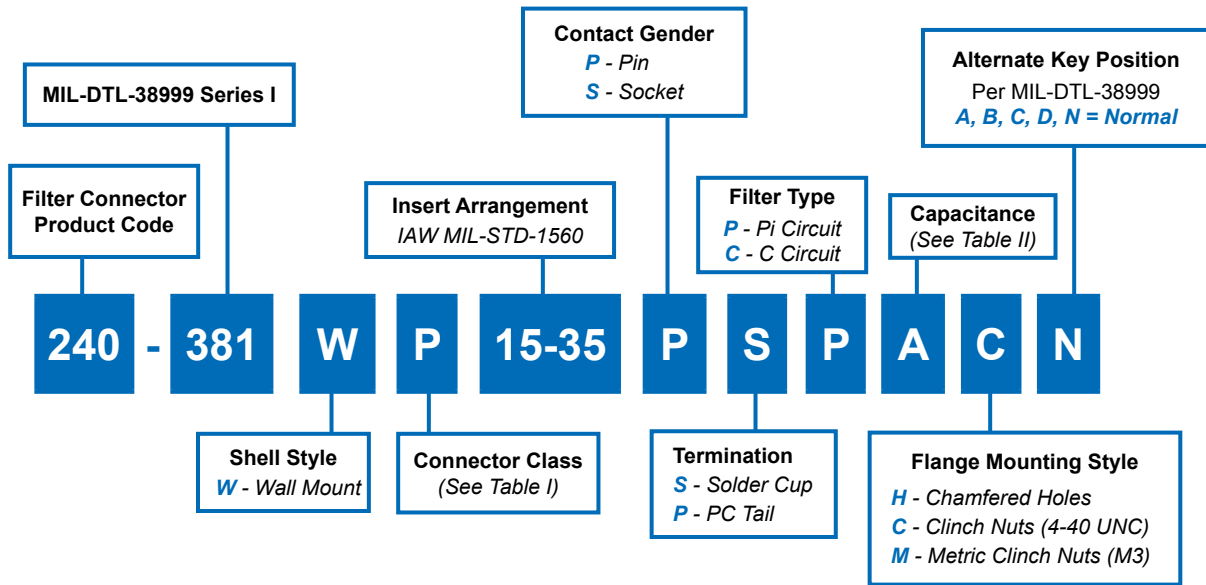

C

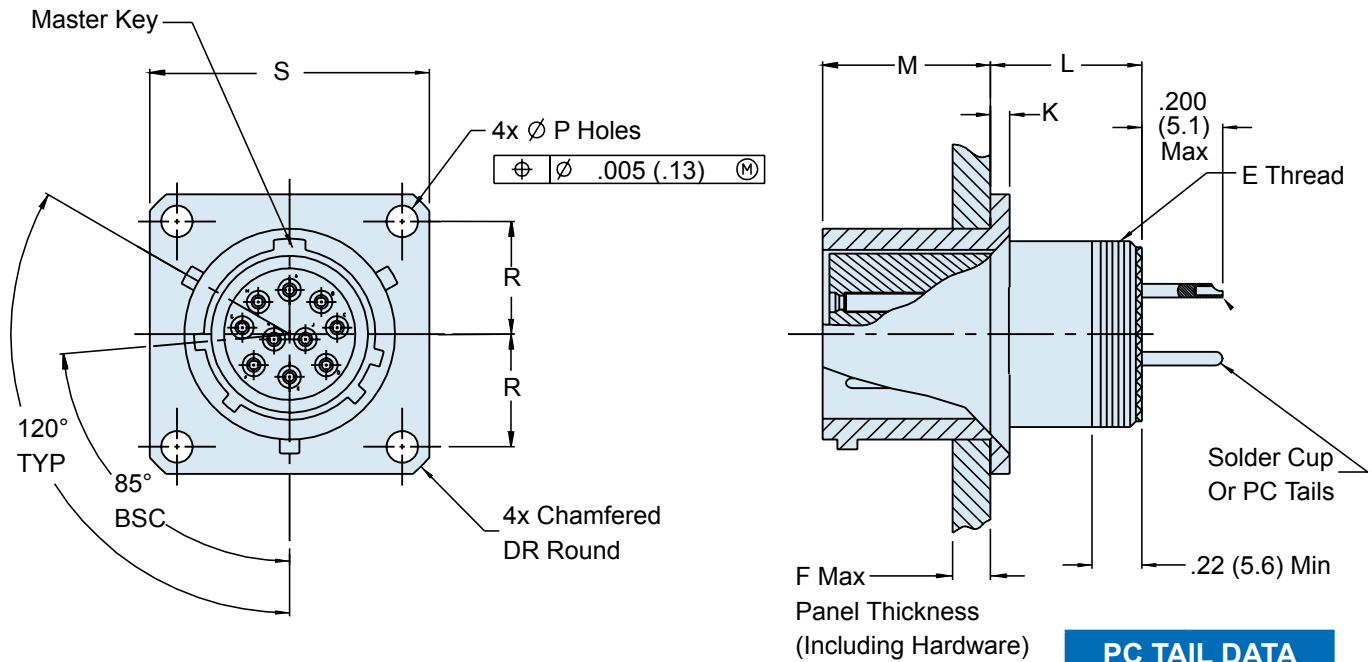

W - Wall Mount

PC TAIL DATA	
Contact Size	PC Tail Ø
22D	.020 .018
20	.024 .029
16	.038 .042

240-381W MIL-DTL-38999 Series I Type Filter Connector Wall Mount Receptacle



EMI/EMP
Filters

MIL-DTL-38999 Series I Square Flange Panel Cutouts					
Shell Size Code	Shell Size	∅ K Min	∅ L Min	M Holes	N BSC
A	09	.656 (16.7)	.516 (13.1)	.133 (3.4) .123 (3.1)	.719 (18.3)
B	11	.796 (20.2)	.625 (15.9)	.133 (3.4) .123 (3.1)	.812 (20.6)
C	13	.922 (23.4)	.750 (19.1)	.133 (3.4) .123 (3.1)	.906 (23.0)
D	15	1.047 (26.6)	.906 (23.0)	.133 (3.4) .123 (3.1)	.969 (24.6)
E	17	1.219 (31.0)	1.016 (25.8)	.133 (3.4) .123 (3.1)	1.062 (27.0)
F	19	1.297 (32.9)	1.141 (29.0)	.133 (3.4) .123 (3.1)	1.156 (29.4)
G	21	1.422 (36.1)	1.266 (32.2)	.133 (3.4) .123 (3.1)	1.250 (31.8)
H	23	1.547 (39.3)	1.375 (34.9)	.159 (4.0) .149 (3.8)	1.375 (34.9)
J	25	1.672 (42.5)	1.484 (37.7)	.155 (3.9) .145 (3.7)	1.500 (38.1)

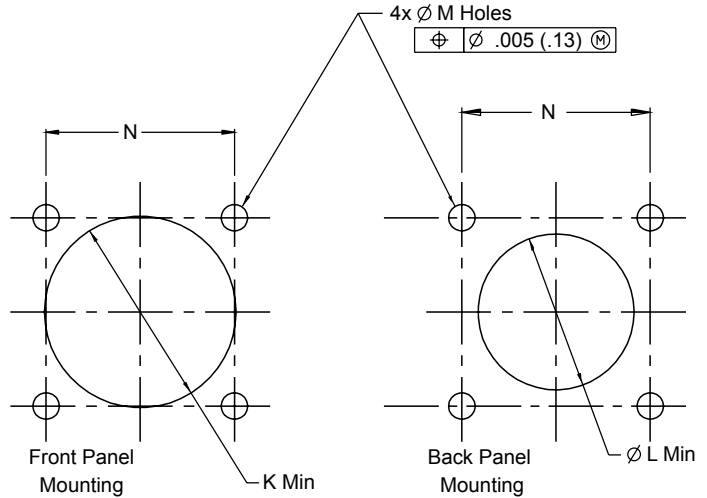

TABLE I: CONNECTOR CLASS			
SYM	CLASS	MATERIAL	FINISH DESCRIPTION
M	Environmental	Aluminum	Electroless Nickel
MT	Environmental	Aluminum	Ni-PTFE 1000 Hour Grey™ Nickel Fluorocarbon Polymer
NF	Environmental	Aluminum	Cadmium O.D. Over Electroless Nickel
P	Environmental	Stainless Steel	Electro-Deposited Nickel
ZN	Environmental	Aluminum	Zinc-Nickel Over Electroless Nickel

TABLE II: CAPACITOR ARRAY CODE CAPACITANCE RANGE		
CLASS	PI - CIRCUIT (pF)	C - CIRCUIT (pF)
X*	160,000 - 240,000	80,000 - 120,000
Y*	80,000 - 120,000	40,000 - 60,000
Z*	60,000 - 90,000	30,000 - 45,000
A	38,000 - 56,000	19,000 - 28,000
B	32,000 - 45,000	16,000 - 22,500
C	18,000 - 33,000	9,000 - 16,500
D	8,000 - 12,000	4,000 - 6,000
E	3,300 - 5,000	1,650 - 2,500
F	800 - 1,300	400 - 650
G	400 - 600	200 - 300

* Reduced DWV – Please consult factory.

DIMENSIONS								
SHELL SIZE	E THREADS	F MAX	K + .015 (.4) - .000 (0)	L MAX	M + .000 (0) - .005 (.13)	∅ P + .010 (.3) - .005 (.13)	R BSC	S +/- .020 (5.1)
9	.6875-24 UNEF-2A	.234 (5.9)	.085 (2.2)	.469 (11.9)	.820 (20.8)	.128 (3.3)	.3595 (9.1)	.938 (23.8)
11	.8125-20 UNEF-2A	.234 (5.9)	.085 (2.2)	.469 (11.9)	.820 (20.8)	.128 (3.3)	.406 (10.3)	1.031 (26.2)
13	.9375-20 UNEF-2A	.234 (5.9)	.085 (2.2)	.469 (11.9)	.820 (20.8)	.128 (3.3)	.453 (11.5)	1.125 (28.6)
15	1.0625-18 UNEF-2A	.234 (5.9)	.085 (2.2)	.469 (11.9)	.820 (20.8)	.128 (3.3)	.4845 (12.3)	1.219 (31.0)
17	1.1875-18 UNEF-2A	.234 (5.9)	.085 (2.2)	.469 (11.9)	.820 (20.8)	.128 (3.3)	.531 (13.5)	1.312 (33.3)
19	1.3125-18 UNEF-2A	.234 (5.9)	.085 (2.2)	.469 (11.9)	.820 (20.8)	.128 (3.3)	.578 (14.7)	1.438 (36.5)
21	1.4375-10 UNEF-2A	.204 (5.2)	.115 (2.9)	.500 (12.7)	.820 (20.8)	.128 (3.3)	.625 (15.9)	1.562 (39.7)
23	1.5625-18 UNEF-2A	.204 (5.2)	.115 (2.9)	.500 (12.7)	.790 (20.1)	.147 (3.7)	.6875 (17.5)	1.688 (42.9)
25	1.6875-18 UNEF-2A	.193 (4.9)	.115 (2.9)	.500 (12.7)	.790 (20.1)	.147 (3.7)	.750 (19.1)	1.688 (42.9)

240-381R MIL-DTL-38999 Series I Type Filter Connector Wall Mount Receptacle with Crimp Removable Socket Contacts

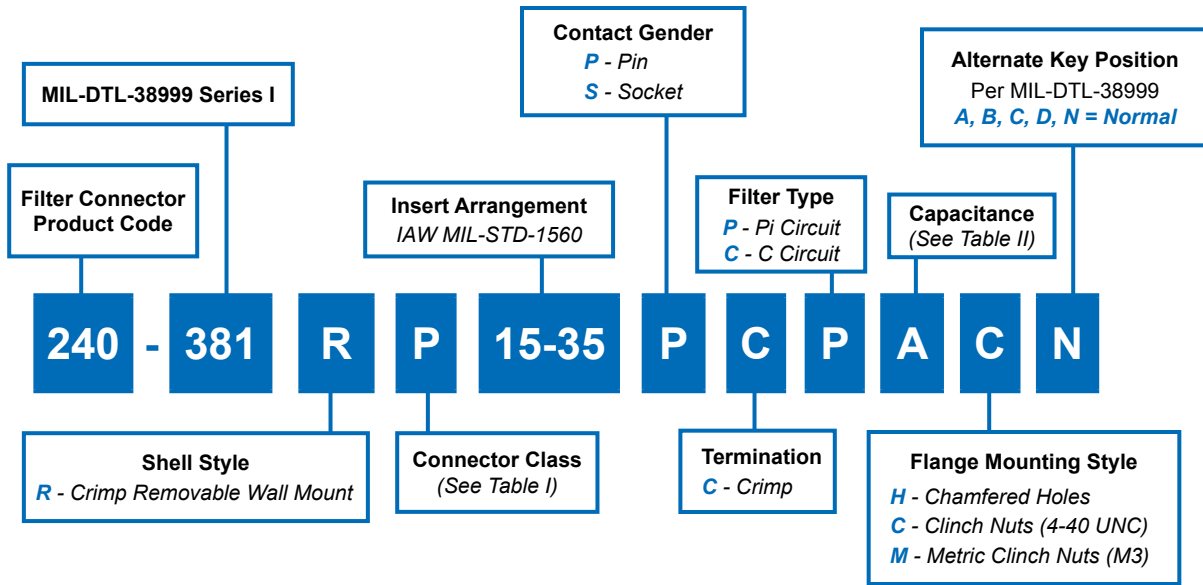

NOTE: Crimp removable socket contacts to conform to MIL-C-39029/57-358, Size 16, MIL-C-39029/57-357 Size 20, and MIL-C-39029/57-354 Size 22D (Supplied loose).

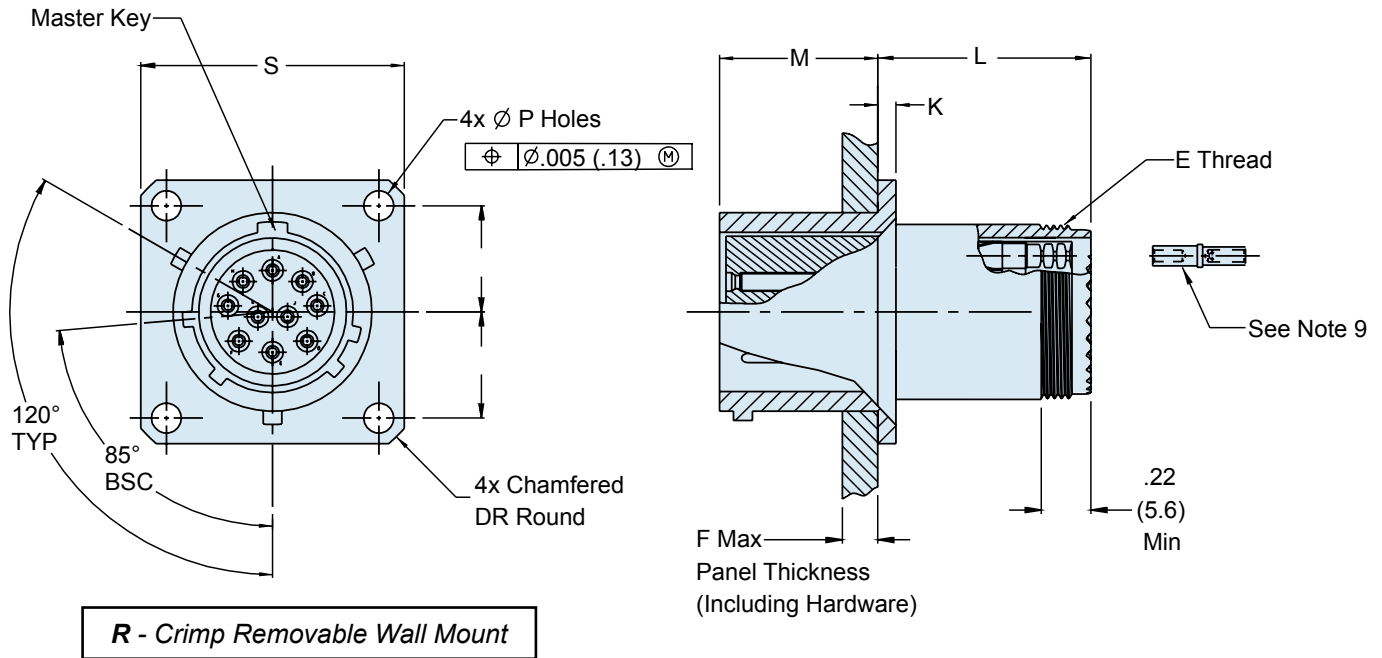

240-381R MIL-DTL-38999 Series I Type Filter Connector Wall Mount Receptacle with Crimp Removable Socket Contacts



MIL-DTL-38999 Series I Square Flange Panel Cutouts					
Shell Size Code	Shell Size	∅ K Min	∅ L Min	M Holes	N BSC
A	09	.656 (16.7)	.516 (13.1)	.133 (3.4) .123 (3.1)	.719 (18.3)
B	11	.796 (20.2)	.625 (15.9)	.133 (3.4) .123 (3.1)	.812 (20.6)
C	13	.922 (23.4)	.750 (19.1)	.133 (3.4) .123 (3.1)	.906 (23.0)
D	15	1.047 (26.6)	.906 (23.0)	.133 (3.4) .123 (3.1)	.969 (24.6)
E	17	1.219 (31.0)	1.016 (25.8)	.133 (3.4) .123 (3.1)	1.062 (27.0)
F	19	1.297 (32.9)	1.141 (29.0)	.133 (3.4) .123 (3.1)	1.156 (29.4)
G	21	1.422 (36.1)	1.266 (32.2)	.133 (3.4) .123 (3.1)	1.250 (31.8)
H	23	1.547 (39.3)	1.375 (34.9)	.159 (4.0) .149 (3.8)	1.375 (34.9)
J	25	1.672 (42.5)	1.484 (37.7)	.155 (3.9) .145 (3.7)	1.500 (38.1)

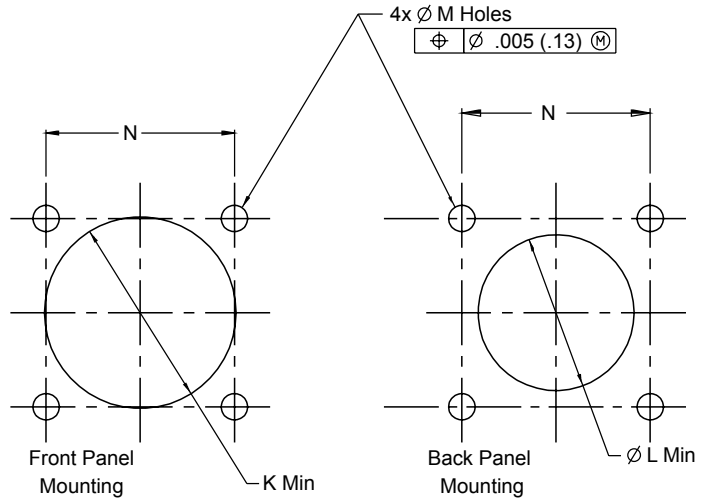

TABLE I: CONNECTOR CLASS			
SYM	CLASS	MATERIAL	FINISH DESCRIPTION
M	Environmental	Aluminum	Electroless Nickel
MT	Environmental	Aluminum	Ni-PTFE 1000 Hour Grey™ Nickel Fluorocarbon Polymer
NF	Environmental	Aluminum	Cadmium O.D. Over Electroless Nickel
P	Environmental	Stainless Steel	Electro-Deposited Nickel
ZN	Environmental	Aluminum	Zinc-Nickel Over Electroless Nickel

TABLE II: CAPACITOR ARRAY CODE CAPACITANCE RANGE		
CLASS	PI - CIRCUIT (pF)	C - CIRCUIT (pF)
X*	160,000 - 240,000	80,000 - 120,000
Y*	80,000 - 120,000	40,000 - 60,000
Z*	60,000 - 90,000	30,000 - 45,000
A	38,000 - 56,000	19,000 - 28,000
B	32,000 - 45,000	16,000 - 22,500
C	18,000 - 33,000	9,000 - 16,500
D	8,000 - 12,000	4,000 - 6,000
E	3,300 - 5,000	1,650 - 2,500
F	800 - 1,300	400 - 650
G	400 - 600	200 - 300

* Reduced DWV – Please consult factory.

DIMENSIONS								
SHELL SIZE	E THREADS	F MAX	K + .015 (.4) - .000 (0)	L MAX	M + .000 (0) - .005 (.13)	∅ P + .010 (.3) - .005 (.13)	R BSC	S +/- .020 (5.1)
9	.6875-24 UNEF-2A	.234 (5.9)	.085 (2.2)	1.170 (29.7)	.820 (20.8)	.128 (3.3)	.3595 (9.1)	.938 (23.8)
11	.8125-20 UNEF-2A	.234 (5.9)	.085 (2.2)	1.170 (29.7)	.820 (20.8)	.128 (3.3)	.406 (10.3)	1.031 (26.2)
13	.9375-20 UNEF-2A	.234 (5.9)	.085 (2.2)	1.170 (29.7)	.820 (20.8)	.128 (3.3)	.453 (11.5)	1.125 (28.6)
15	1.0625-18 UNEF-2A	.234 (5.9)	.085 (2.2)	1.170 (29.7)	.820 (20.8)	.128 (3.3)	.4845 (12.3)	1.219 (31.0)
17	1.1875-18 UNEF-2A	.234 (5.9)	.085 (2.2)	1.170 (29.7)	.820 (20.8)	.128 (3.3)	.531 (13.5)	1.312 (33.3)
19	1.3125-18 UNEF-2A	.234 (5.9)	.085 (2.2)	1.170 (29.7)	.820 (20.8)	.128 (3.3)	.578 (14.7)	1.438 (36.5)
21	1.4375-10 UNEF-2A	.204 (5.2)	.115 (2.9)	1.200 (30.48)	.820 (20.8)	.128 (3.3)	.625 (15.9)	1.562 (39.7)
23	1.5625-18 UNEF-2A	.204 (5.2)	.115 (2.9)	1.200 (30.48)	.790 (20.1)	.147 (3.7)	.6875 (17.5)	1.688 (42.9)
25	1.6875-18 UNEF-2A	.193 (4.9)	.115 (2.9)	1.200 (30.48)	.790 (20.1)	.147 (3.7)	.750 (19.1)	1.688 (42.9)

240-381J MIL-DTL-38999 Series I Type Filter Connector Jam Nut Receptacle

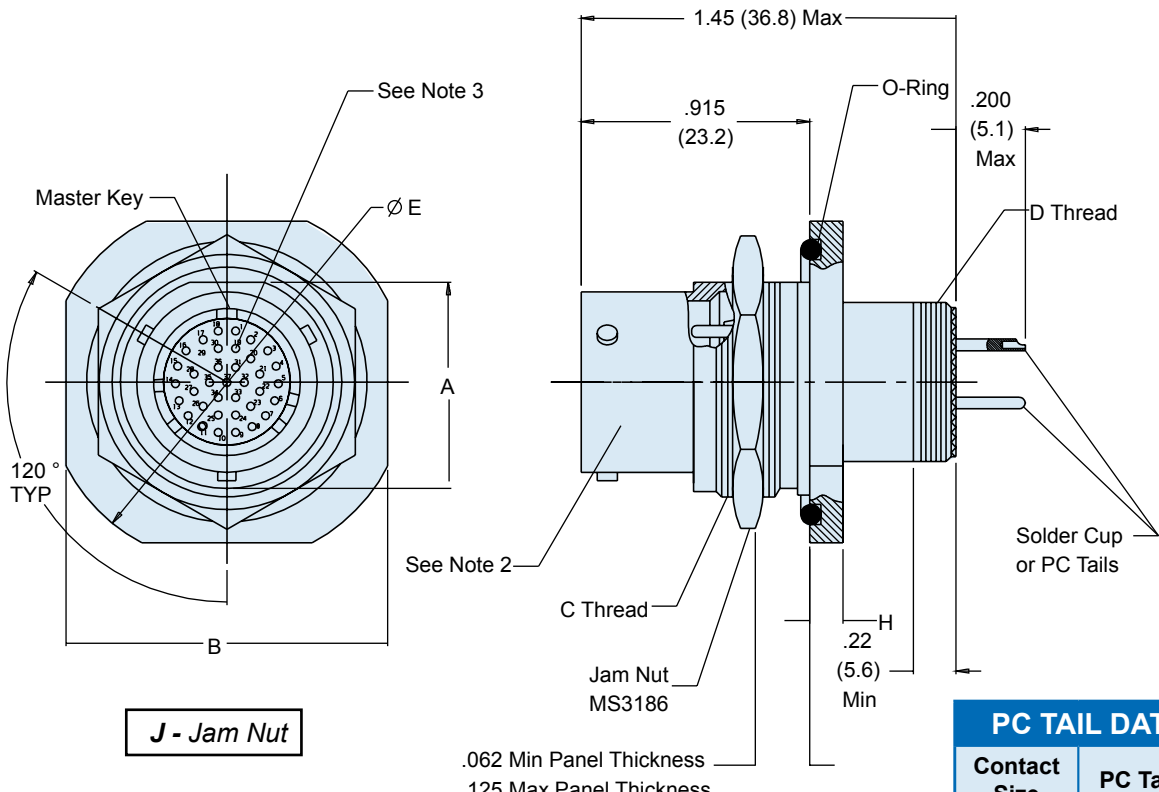
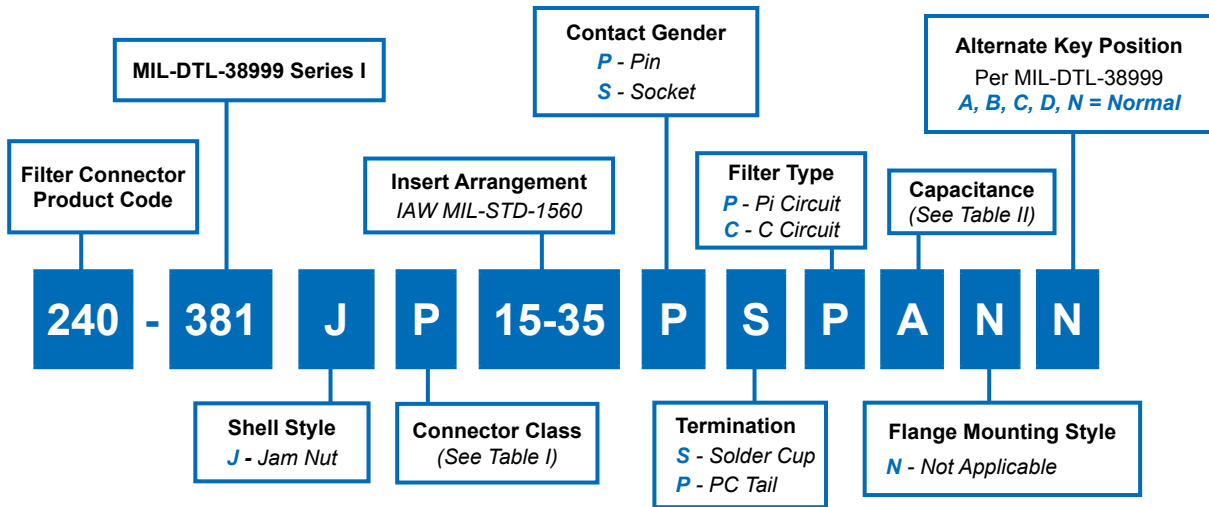

J - Jam Nut

PC TAIL DATA	
Contact Size	PC Tail Ø
22D	.020
	.018
20	.024
	.029
16	.038
	.042

240-381J MIL-DTL-38999 Series I Type Filter Connector Jam Nut Receptacle



**TABLE II: CAPACITOR ARRAY CODE
CAPACITANCE RANGE**

CLASS	PI - CIRCUIT (pF)	C - CIRCUIT (pF)
X*	160,000 - 240,000	80,000 - 120,000
Y*	80,000 - 120,000	40,000 - 60,000
Z*	60,000 - 90,000	30,000 - 45,000
A	38,000 - 56,000	19,000 - 28,000
B	32,000 - 45,000	16,000 - 22,500
C	18,000 - 33,000	9,000 - 16,500
D	8,000 - 12,000	4,000 - 6,000
E	3,300 - 5,000	1,650 - 2,500
F	800 - 1,300	400 - 650
G	400 - 600	200 - 300

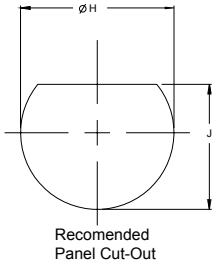

* Reduced DWV – Please consult factory.

**MIL-DTL-38999 Series I
Jam Nut Panel Cutout**

SHELL SIZE CODE	SHELL SIZE	Ø H	J
A	09	.710 (18.0)	.670 (17.0)
		.700 (17.8)	.660 (16.8)
B	11	.835 (21.2)	.771 (19.6)
		.825 (21.0)	.761 (19.3)
C	13	1.020 (25.9)	.955 (24.3)
		1.010 (25.7)	.945 (24.0)
D	15	1.145 (29.1)	1.085 (27.6)
		1.135 (28.8)	1.075 (27.3)
E	17	1.270 (32.3)	1.210 (30.7)
		1.260 (32.0)	1.200 (30.5)
F	19	1.395 (35.4)	1.335 (33.9)
		1.385 (35.2)	1.325 (33.7)
G	21	1.520 (38.6)	1.460 (37.1)
		1.510 (38.4)	1.450 (36.8)
H	23	1.645 (41.8)	1.585 (40.3)
		1.635 (41.5)	1.575 (40.0)
J	25	1.770 (45.0)	1.710 (43.4)
		1.760 (44.7)	1.700 (43.2)

TABLE I: CONNECTOR CLASS

SYM	CLASS	MATERIAL	FINISH DESCRIPTION
M	Environmental	Aluminum	Electroless Nickel
MT	Environmental	Aluminum	Ni-PTFE 1000 Hour Grey™ Nickel Fluorocarbon Polymer
NF	Environmental	Aluminum	Cadmium O.D. Over Electroless Nickel
P	Environmental	Stainless Steel	Electro-Deposited Nickel
ZN	Environmental	Aluminum	Zinc-Nickel Over Electroless Nickel

DIMENSIONS

SHELL SIZE	A	B	C THREAD CLASS 2A UNEF PLATED	D THREAD CLASS 2A UNEF PLATED	E DIA	F	G DIA	H
9	.855 (21.7)	1.078 (27.4)	.6875-24	.4375-28	1.188 (30.2)	.670 (17.0)	.709 (18.0)	.120 (3.0)
	.645 (16.4)	1.046 (26.6)				.661 (16.8)	.700 (17.8)	.100 (2.5)
11	.755 (19.2)	1.266 (32.2)	.8125-20	.5625-24	1.375 (34.9)	.771 (19.6)	.834 (21.2)	.120 (3.0)
	.745 (18.9)	1.234 (31.3)				.762 (19.4)	.825 (21.0)	.100 (2.5)
13	.942 (23.9)	1.391 (35.3)	1.0000-20	.8875-24	1.500 (38.1)	.955 (24.3)	1.019 (25.9)	.120 (3.0)
	.932 (23.7)	1.359 (34.5)				.946 (24.0)	1.010 (25.7)	.100 (2.5)
15	1.066 (27.1)	1.516 (38.5)	1.1250-18	.8125-20	1.625 (41.3)	1.085 (27.6)	1.144 (29.1)	.120 (3.0)
	1.056 (26.8)	1.484 (37.7)				1.076 (27.3)	1.135 (28.8)	.100 (2.5)
17	1.191 (30.3)	1.641 (41.7)	1.2500-18	.9375-20	1.750 (44.5)	1.210 (30.7)	1.269 (32.2)	.120 (3.0)
	1.181 (30.0)	1.609 (40.9)				1.201 (30.5)	1.260 (32.0)	.100 (2.5)
19	1.316 (33.4)	1.828 (46.4)	1.3750-18	1.0625-18	1.938 (49.2)	1.335 (33.9)	1.394 (35.4)	.151 (3.8)
	1.306 (33.2)	1.796 (45.6)				1.326 (33.7)	1.385 (35.2)	.130 (3.3)
21	1.441 (36.6)	1.954 (49.6)	1.5000-18	1.1875-18	2.062 (52.4)	1.460 (37.1)	1.519 (38.6)	.151 (3.8)
	1.431 (36.3)	1.922 (48.8)				1.451 (36.9)	1.510 (38.4)	.130 (3.3)
23	1.566 (39.8)	2.078 (52.8)	1.6250-18	1.3125-18	2.188 (55.6)	1.585 (40.3)	1.644 (41.8)	.151 (3.8)
	1.556 (39.5)	2.046 (52.0)				1.578 (40.1)	1.635 (41.5)	.130 (3.3)
25	1.691 (43.0)	2.204 (56.0)	1.7500-18	1.4375-18	2.312 (58.7)	1.710 (43.4)	1.769 (44.9)	.151 (3.8)
	1.681 (42.7)	2.172 (55.2)				1.701 (43.2)	1.760 (44.7)	.130 (3.3)

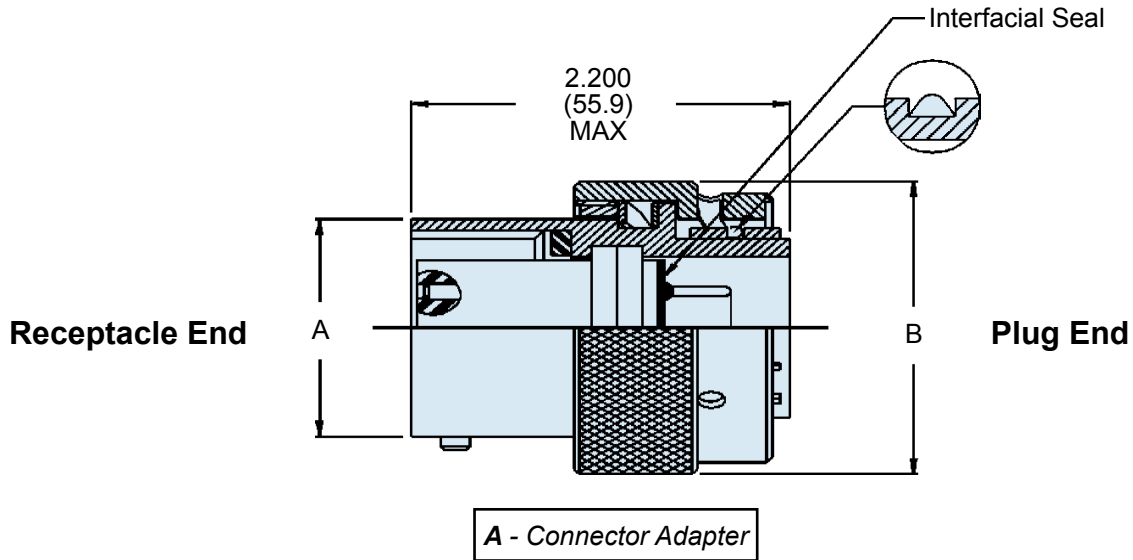
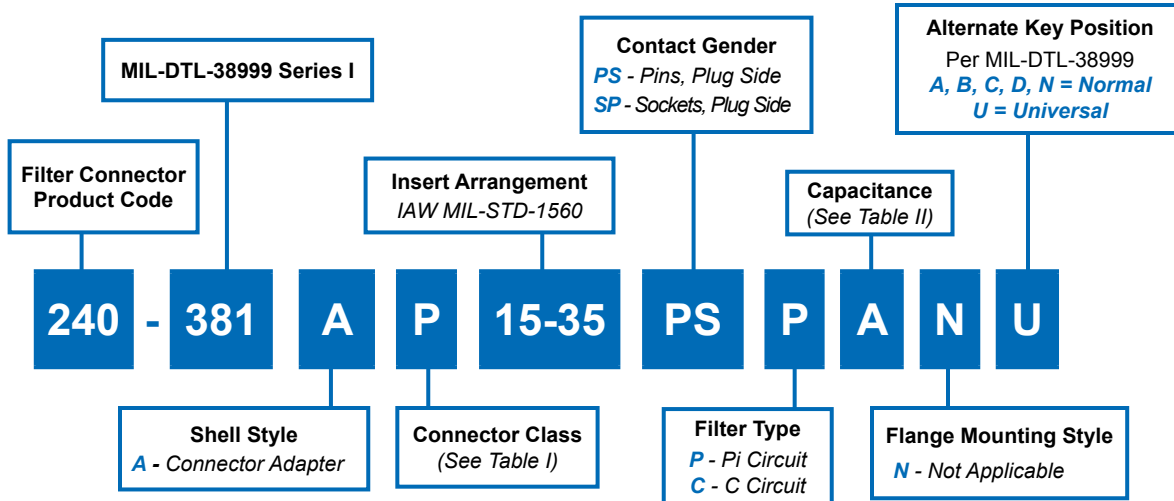

* Please consult factory for Pin/Pin and/or Socket/Socket contact arrangements.

240-381A
MIL-DTL-38999 Series I Filter Connector
Connector Adapter



TABLE I: CONNECTOR CLASS

SYM	CLASS	MATERIAL	FINISH DESCRIPTION
M	Environmental	Aluminum	Electroless Nickel
MT	Environmental	Aluminum	Ni-PTFE 1000 Hour Grey™ Nickel Fluorocarbon Polymer)
NF	Environmental	Aluminum	Cadmium O.D. Over Electroless Nickel
P	Environmental	Stainless Steel	Electro-Deposited Nickel
ZN	Environmental	Aluminum	Zinc-Nickel Over Electroless Nickel

TABLE II: CAPACITOR ARRAY CODE CAPACITANCE RANGE

CLASS	PI - CIRCUIT (pF)	C - CIRCUIT (pF)
X*	160,000 - 240,000	80,000 - 120,000
Y*	80,000 - 120,000	40,000 - 60,000
Z*	60,000 - 90,000	30,000 - 45,000
A	38,000 - 56,000	19,000 - 28,000
B	32,000 - 45,000	16,000 - 22,500
C	18,000 - 33,000	9,000 - 16,500
D	8,000 - 12,000	4,000 - 6,000
E	3,300 - 5,000	1,650 - 2,500
F	800 - 1,300	400 - 650
G	400 - 600	200 - 300

* Reduced DWV – Please consult factory.

SHELL DIAMETER

Shell Size	A Max	B Max
09	.573 (14.6)	.910 (23.1)
11	.701 (17.8)	1.035 (26.3)
13	.851 (21.6)	1.210 (30.7)
15	.976 (24.8)	1.330 (33.8)
17	1.101 (28.0)	1.455 (37.0)
19	1.208 (30.7)	1.570 (39.9)
21	1.333 (33.9)	1.695 (43.1)
23	1.458 (37.0)	1.800 (45.7)
25	1.583 (40.2)	1.925 (48.9)

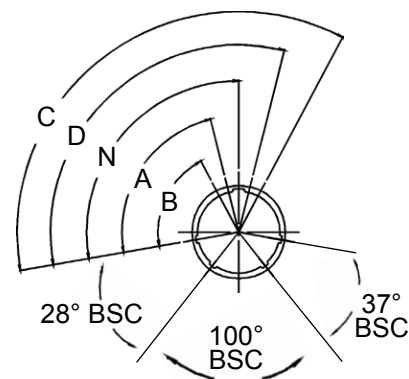

MASTER KEY POSITION

NORMAL	A°	B°	C°	D°
100°	79°	66°	134°	121°



**Glenair MIL-DTL-38999 Series II Type
Low-Profile Filter Connector with Bayonet Coupling
Master How to Order • Part Number Breakdown**

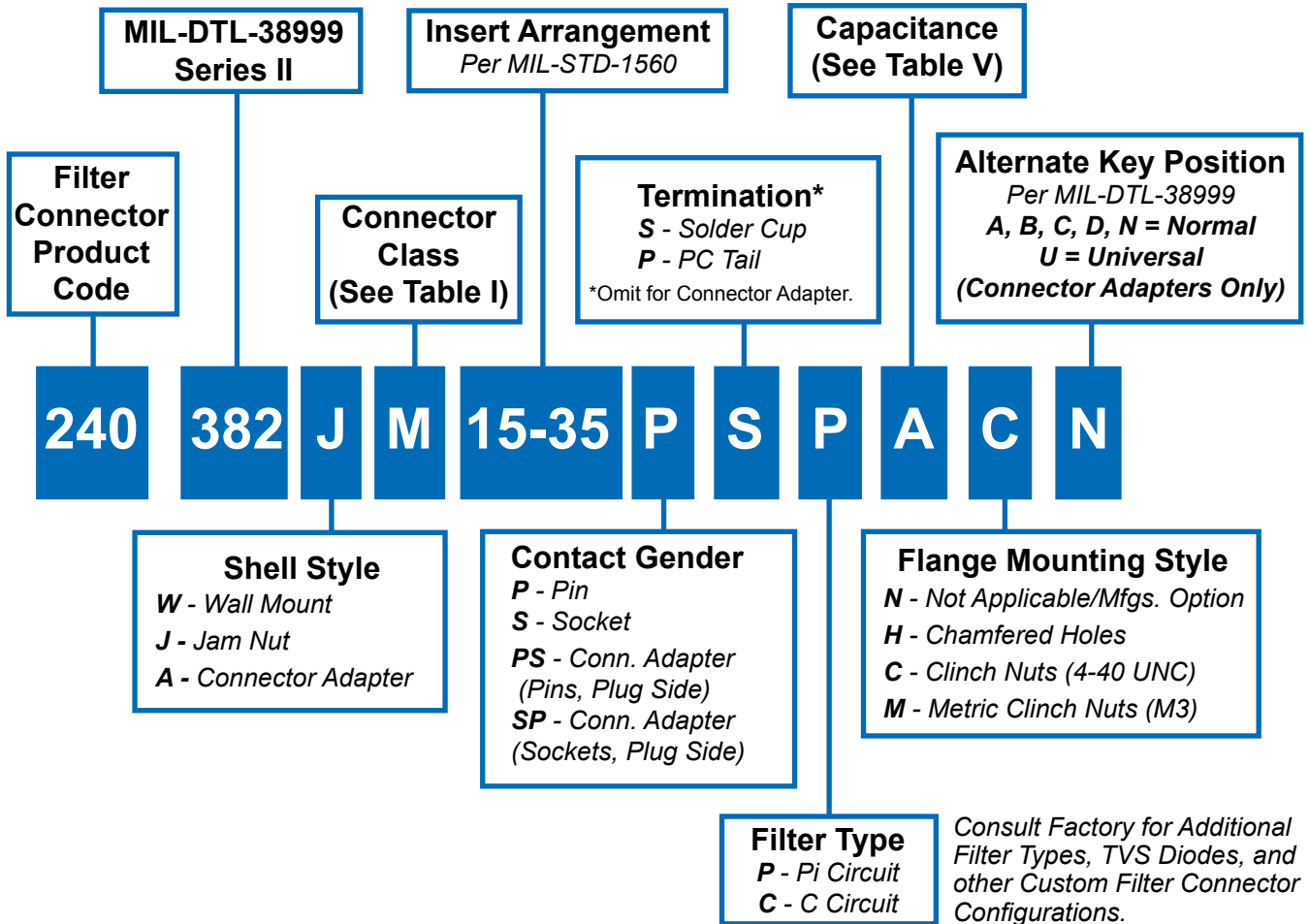

Consult Factory for Additional Filter Types, TVS Diodes, and other Custom Filter Connector Configurations.

SYM	CLASS	MATERIAL	FINISH DESCRIPTION
M	Environmental	Aluminum	Electroless Nickel
MT	Environmental	Aluminum	Ni-PTFE 1000 Hour Grey™ Nickel Fluorocarbon Polymer
NF	Environmental	Aluminum	Cadmium O.D. Over Electroless Nickel
P	Environmental	Stainless Steel	Electro-Deposited Nickel
ZN	Environmental	Aluminum	Zinc-Nickel Over Electroless Nickel
H2	Hermetic	Stainless Steel	Electroless Nickel

CLASS	PI - CIRCUIT (pF)	C - CIRCUIT (pF)
X*	160,000 - 240,000	80,000 - 120,000
Y*	80,000 - 120,000	40,000 - 60,000
Z*	60,000 - 90,000	30,000 - 45,000
A	38,000 - 56,000	19,000 - 28,000
B	32,000 - 45,000	16,000 - 22,500
C	18,000 - 33,000	9,000 - 16,500
D	8,000 - 12,000	4,000 - 6,000
E	3,300 - 5,000	1,650 - 2,500
F	800 - 1,300	400 - 650
G	400 - 600	200 - 300

* Reduced DWV – Please consult factory.

Glenair MIL-DTL-38999 Series II Type Low-Profile Filter Connector with Bayonet Coupling Reference Information

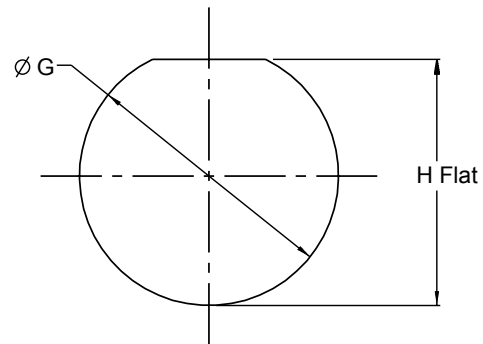
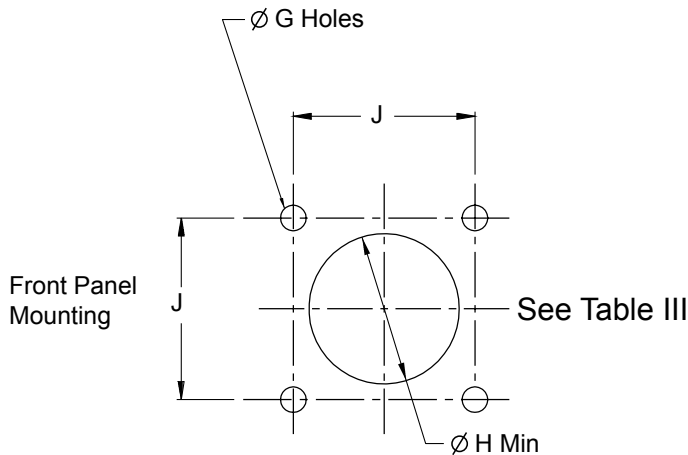

**TABLE III: SQUARE FLANGE
PANEL CUT-OUTS**

Shell Size	Ø G Holes	Ø H Min	Ø J BSC
8	.133 (3.4)	.570	.594
	.123 (3.1)	(14.5)	(15.1)
10	.133 (3.4)	.690	.719
	.123 (3.1)	(17.5)	(18.3)
12	.133 (3.4)	.820	.812
	.123 (3.1)	(20.8)	(20.6)
14	.133 (3.4)	.940	.906
	.123 (3.1)	(23.9)	(23.0)
16	.133 (3.4)	1.070	.969
	.123 (3.1)	(27.2)	(24.6)
18	.133 (3.4)	1.190	1.062
	.123 (3.1)	(30.2)	(27.0)
20	.133 (3.4)	1.320	1.156
	.123 (3.1)	(33.5)	(29.4)
22	.159 (4.0)	1.440	1.250
	.149 (3.8)	(36.6)	(31.8)
24	.159 (4.0)	1.570	1.375
	.149 (3.8)	(39.9)	(34.9)

**PANEL IV: JAM-NUT
PANEL CUT-OUTS**

SHELL SIZE	Ø G	H Flat
08	.894 (22.7)	.833 (21.2)
	.884 (22.5)	.823 (20.9)
10	1.020 (25.9)	.957 (24.3)
	1.010 (25.7)	.947 (24.1)
12	1.144 (29.1)	1.081 (27.5)
	1.134 (28.8)	1.071 (27.2)
14	1.269 (32.2)	1.206 (30.6)
	1.259 (32.0)	1.196 (30.4)
16	1.394 (35.4)	1.336 (33.9)
	1.384 (35.2)	1.326 (33.7)
18	1.520 (38.6)	1.456 (37.0)
	1.510 (38.4)	1.446 (36.7)
20	1.645 (41.8)	1.581 (40.2)
	1.635 (41.5)	1.571 (39.9)
22	1.750 (44.5)	1.706 (43.3)
	1.740 (44.2)	1.696 (43.1)
24	1.895 (48.1)	1.831 (46.5)
	1.885 (47.9)	1.821 (46.3)

APPLICATION NOTES

- Materials/Finishes: Shells, Barrel, Coupling Nut, Jam Nut - See Table I
Insulators - high grade rigid dielectric/N.A.
Seals - Fluorosilicone
PC Tail & Solder Cup contacts: 50µ" Gold over 50µ" Nickel
- Assembly to be identified with Glenair's name, part number, and date code - space permitting.
- Insert Arrangement in accordance with MIL-STD-1560.
(Arrangement shown for reference only)
- EMI Circular Filter Receptacle connector designed to meet requirements of MIL-STD-2120 and MIL-DTL-38999, Series II.
- All contacts to have identical filter value. Other filter arrangements available, contact factory.
- Electrical Ratings: DWW- 500 VDC; Standard Operating Voltage 200 Volts DC; Current Rating 5 Amps (size 22);
- Insulation Resistance: 5000 MegOhms Min. at 200 VDC.
- Operating Temperature -55°C to +125°C (Env Class Connectors)
- Other filter styles (C-L, L-C, Unbalanced PI, Multi-Stage, Multi-Value) are available, please consult the factory.
- Metric Dimensions (mm) are indicated in parentheses.

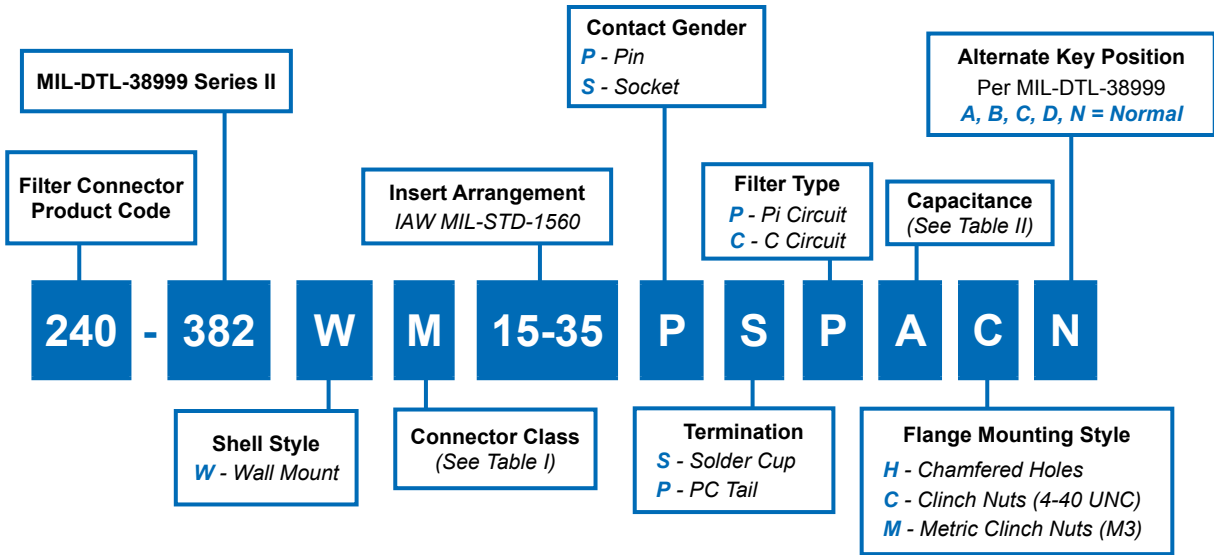

C

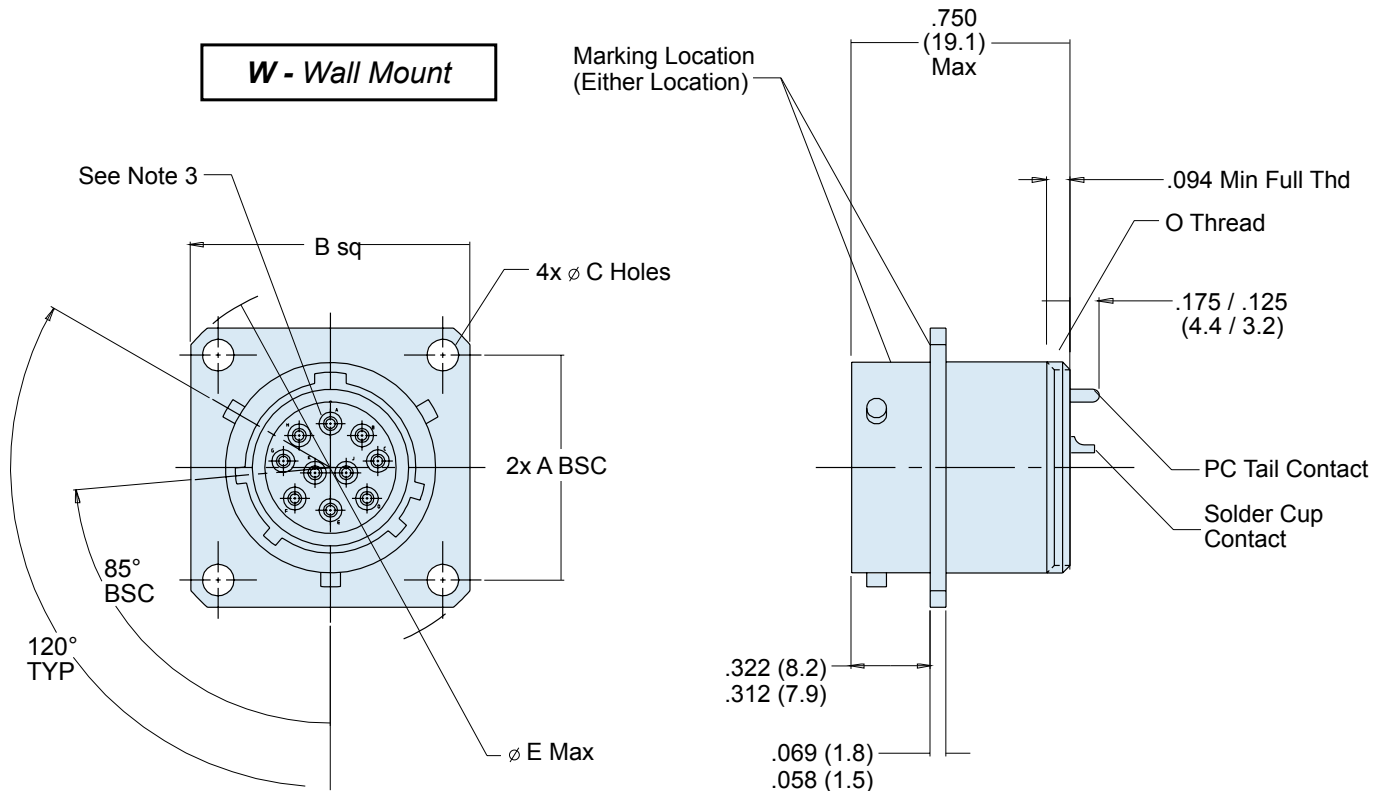

240-382W MIL-DTL-38999 Series II Filter Connector Wall Mount Receptacle

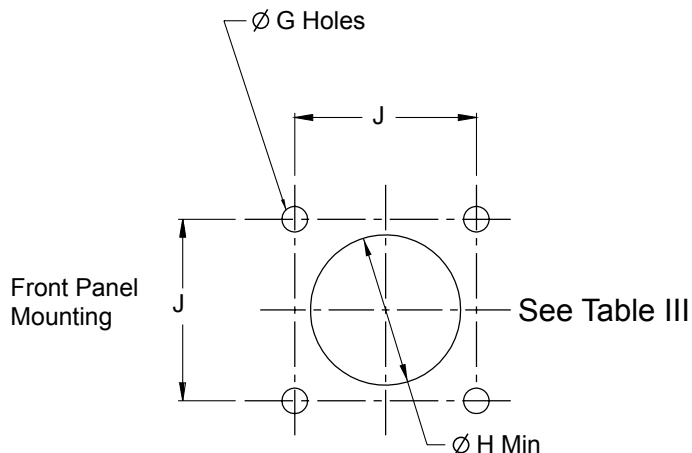

TABLE II: CAPACITOR ARRAY CODE CAPACITANCE RANGE		
CLASS	PI - CIRCUIT (pF)	C - CIRCUIT (pF)
X*	160,000 - 240,000	80,000 - 120,000
Y*	80,000 - 120,000	40,000 - 60,000
Z*	60,000 - 90,000	30,000 - 45,000
A	38,000 - 56,000	19,000 - 28,000
B	32,000 - 45,000	16,000 - 22,500
C	18,000 - 33,000	9,000 - 16,500
D	8,000 - 12,000	4,000 - 6,000
E	3,300 - 5,000	1,650 - 2,500
F	800 - 1,300	400 - 650
G	400 - 600	200 - 300

TABLE I: CONNECTOR CLASS			
SYM	CLASS	MATERIAL	FINISH DESCRIPTION
M	Environmental	Aluminum	Electroless Nickel
MT	Environmental	Aluminum	Ni-PTFE 1000 Hour Grey™ Nickel Fluorocarbon Polymer
NF	Environmental	Aluminum	Cadmium O.D. Over Electroless Nickel
P	Environmental	Stainless Steel	Electro-Deposited Nickel
ZN	Environmental	Aluminum	Zinc-Nickel Over Electroless Nickel

* Reduced DWV – Please consult factory.

Consult Factory for Additional Filter Types, TVS Diodes, and other Custom Filter Connector Configurations.

TABLE III: SQUARE FLANGE PANEL CUT-OUTS			
Shell Size	Ø G Holes	Ø H Min	Ø J BSC
8	.133 (3.4)	.570	.594
	.123 (3.1)	(14.5)	(15.1)
10	.133 (3.4)	.690	.719
	.123 (3.1)	(17.5)	(18.3)
12	.133 (3.4)	.820	.812
	.123 (3.1)	(20.8)	(20.6)
14	.133 (3.4)	.940	.906
	.123 (3.1)	(23.9)	(23.0)
16	.133 (3.4)	1.070	.969
	.123 (3.1)	(27.2)	(24.6)
18	.133 (3.4)	1.190	1.062
	.123 (3.1)	(30.2)	(27.0)
20	.133 (3.4)	1.320	1.156
	.123 (3.1)	(33.5)	(29.4)
22	.159 (4.0)	1.440	1.250
	.149 (3.8)	(36.6)	(31.8)
24	.159 (4.0)	1.570	1.375
	.149 (3.8)	(39.9)	(34.9)

TABLE IV: CONNECTOR DIMENSIONS					
Shell Size	A BSC	B SQ Max	Ø C Holes	D Threads	Ø E Max
8	0.594 (15.1)	0.828 (21.0)	.130 (3.3) .115 (2.9)	.5625-24 UNEF-2A	1.078 (27.4)
	0.719 (18.3)	0.954 (24.2)	.130 (3.3) .115 (2.9)	.6875-24 UNEF-2A	1.256 (31.9)
12	0.812 (20.6)	1.047 (26.6)	.130 (3.3) .115 (2.9)	.8125-20 UNEF-2A	1.391 (35.3)
	0.906 (23.0)	1.141 (29.0)	.130 (3.3) .115 (2.9)	.9375-20 UNEF-2A	1.516 (38.5)
16	0.969 (24.6)	1.234 (31.3)	.130 (3.3) .115 (2.9)	1.0625-18 UNEF-2A	1.641 (41.7)
	1.062 (27.0)	1.328 (33.7)	.130 (3.3) .115 (2.9)	1.1875-18 UNEF-2A	1.766 (44.9)
20	1.156 (29.4)	1.453 (36.9)	.130 (3.3) .115 (2.9)	1.3125-18 UNEF-2A	1.891 (48.0)
	1.25 (31.8)	1.578 (40.1)	.130 (3.3) .115 (2.9)	1.4375-10 UNEF-2A	2.016 (51.2)
24	1.375 (34.9)	1.703 (43.3)	.157 (4.0) .142 (3.6)	1.5625-18 UNEF-2A	2.204 (56.0)



240-382J (Hermetic Version Shown) MIL-DTL-38999 Series II Filter Connector Jam Nut Receptacle

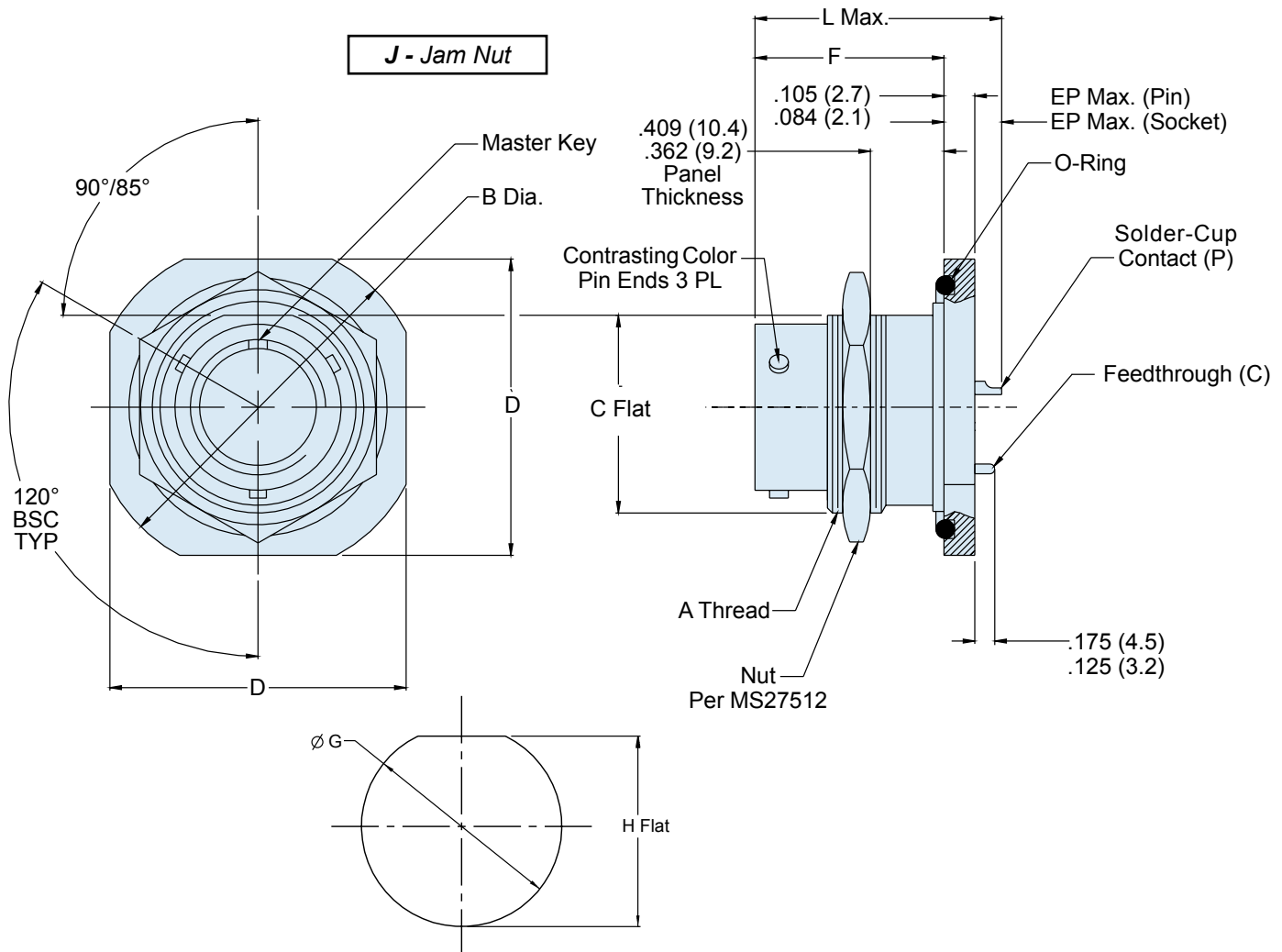
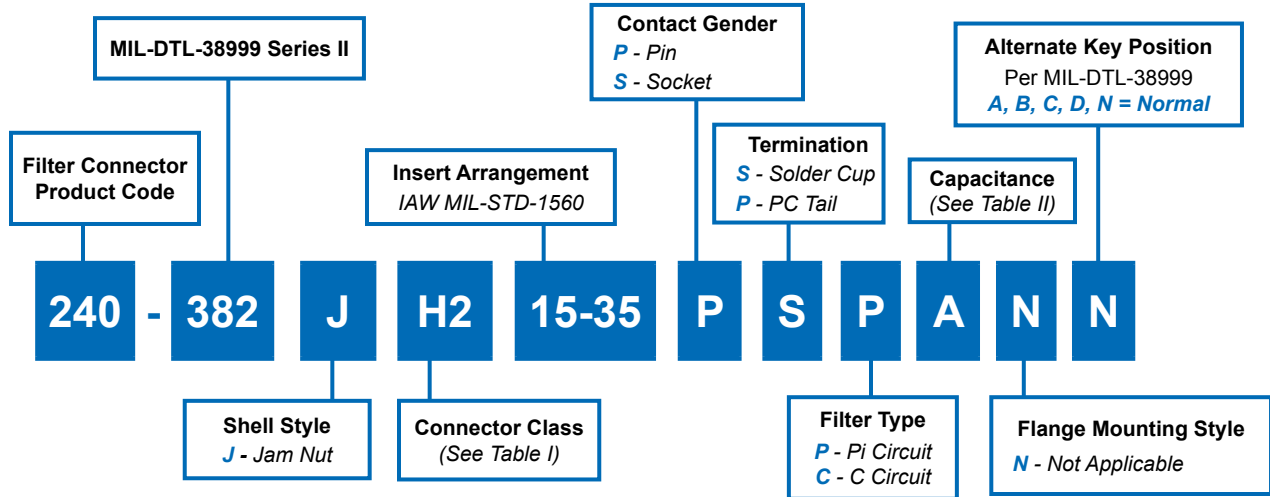

240-382J (Hermetic Version Shown) MIL-DTL-38999 Series II Filter Connector Jam Nut Receptacle



TABLE I: CONNECTOR CLASS

SYM	CLASS	MATERIAL	FINISH DESCRIPTION
M	Environmental	Aluminum	Electroless Nickel
MT	Environmental	Aluminum	Ni-PTFE 1000 Hour Grey™ Nickel Fluorocarbon Polymer
NF	Environmental	Aluminum	Cadmium O.D. Over Electroless Nickel
P	Environmental	Stainless Steel	Electro-Deposited Nickel
ZN	Environmental	Aluminum	Zinc-Nickel Over Electroless Nickel
H2	Hermetic	Stainless Steel	Electroless Nickel

**PANEL IV: JAM-NUT
PANEL CUT-OUTS**

SHELL SIZE	Ø G	H Flat
08	.894 (22.7)	.833 (21.2)
	.884 (22.5)	.823 (20.9)
10	1.020 (25.9)	.957 (24.3)
	1.010 (25.7)	.947 (24.1)
12	1.144 (29.1)	1.081 (27.5)
	1.134 (28.8)	1.071 (27.2)
14	1.269 (32.2)	1.206 (30.6)
	1.259 (32.0)	1.196 (30.4)
16	1.394 (35.4)	1.336 (33.9)
	1.384 (35.2)	1.326 (33.7)
18	1.520 (38.6)	1.456 (37.0)
	1.510 (38.4)	1.446 (36.7)
20	1.645 (41.8)	1.581 (40.2)
	1.635 (41.5)	1.571 (39.9)
22	1.750 (44.5)	1.706 (43.3)
	1.740 (44.2)	1.696 (43.1)
24	1.895 (48.1)	1.831 (46.5)
	1.885 (47.9)	1.821 (46.3)

**TABLE II: CAPACITOR ARRAY CODE
CAPACITANCE RANGE**

CLASS	PI - CIRCUIT (pF)	C - CIRCUIT (pF)
X*	160,000 - 240,000	80,000 - 120,000
Y*	80,000 - 120,000	40,000 - 60,000
Z*	60,000 - 90,000	30,000 - 45,000
A	38,000 - 56,000	19,000 - 28,000
B	32,000 - 45,000	16,000 - 22,500
C	18,000 - 33,000	9,000 - 16,500
D	8,000 - 12,000	4,000 - 6,000
E	3,300 - 5,000	1,650 - 2,500
F	800 - 1,300	400 - 650
G	400 - 600	200 - 300

Consult Factory for Additional Filter Types, TVS Diodes, and other Custom Filter Connector Configurations.

* Reduced DWV – Please consult factory.

TABLE III

SHELL SIZE	A THREAD .1P-.03L-TS	B DIA.	C FLAT	D A/F	EP MAX.	ES MAX.	F	G DIA.	H	L MAX.
08	.875-20 UNEF	1.391 (35.3)	.818 (20.8)	1.266 (32.2)	.281 (7.1)	.359 (9.1)	.743 (18.9)	.894 (22.7)	.833 (21.2)	1.024 (26.0)
		1.359 (34.5)	.811 (20.6)	1.234 (31.3)			.733 (18.6)	.884 (22.5)	.823 (20.9)	
10	.1.000-20 UNEF	1.516 (38.5)	.942 (23.9)	1.391 (35.3)	.281 (7.1)	.359 (9.1)	.743 (18.9)	1.020 (25.9)	.957 (24.3)	1.024 (26.0)
		1.484 (37.7)	.935 (23.7)	1.359 (34.5)			.733 (18.6)	1.010 (25.7)	.947 (24.1)	
12	1.125-18 UNEF	1.641 (41.7)	1.066 (27.1)	1.516 (38.5)	.281 (7.1)	.359 (9.1)	.743 (18.9)	1.144 (29.1)	1.081 (27.5)	1.024 (26.0)
		1.609 (40.9)	1.059 (26.9)	1.484 (37.7)			.733 (18.6)	1.134 (28.8)	1.071 (27.2)	
14	1.250-18 UNEF	1.766 (44.9)	1.191 (30.3)	1.641 (41.7)	.281 (7.1)	.359 (9.1)	.743 (18.9)	1.269 (32.2)	1.206 (30.6)	1.024 (26.0)
		1.734 (44.0)	1.184 (30.1)	1.609 (40.9)			.733 (18.6)	1.259 (32.0)	1.196 (30.4)	
16	1.375-18 UNEF	1.954 (49.6)	1.321 (33.6)	1.797 (45.6)	.281 (7.1)	.359 (9.1)	.743 (18.9)	1.394 (35.4)	1.336 (33.9)	1.024 (26.0)
		1.922 (48.8)	1.314 (33.4)	1.765 (44.8)			.733 (18.6)	1.384 (35.2)	1.326 (33.7)	
18	1.500-18 UNEF	2.032 (51.6)	1.441 (36.6)	1.906 (48.4)	.281 (7.1)	.359 (9.1)	.743 (18.9)	1.520 (38.6)	1.456 (37.0)	1.024 (26.0)
		2.000 (50.8)	1.434 (36.4)	1.874 (47.6)			.733 (18.6)	1.510 (38.4)	1.446 (36.7)	
20	1.625-18 UNEF	2.157 (54.8)	1.566 (39.8)	2.032 (51.6)	.250 (6.4)	.344 (8.7)	.769 (19.5)	1.645 (41.8)	1.581 (40.2)	1.019 (25.9)
		2.125 (54.0)	1.559 (39.6)	2.000 (50.8)			.759 (19.3)	1.635 (41.5)	1.571 (39.9)	
22	1.750-18 UNS	2.281 (57.9)	1.691 (43.0)	2.156 (54.8)	.250 (6.4)	.344 (8.7)	.769 (19.5)	1.750 (44.5)	1.706 (43.3)	1.019 (25.9)
		2.249 (57.1)	1.684 (42.8)	2.124 (53.9)			.759 (19.3)	1.740 (44.2)	1.696 (43.1)	
24	1.875-16 UN	2.406 (61.1)	1.816 (46.1)	2.281 (57.9)	.250 (6.4)	.344 (8.7)	.769 (19.5)	1.895 (48.1)	1.831 (46.5)	1.019 (25.9)
		2.374 (60.3)	1.809 (45.9)	2.249 (57.1)			.759 (19.3)	1.885 (47.9)	1.821 (46.3)	

*Some dimensions do not apply. Consult factory

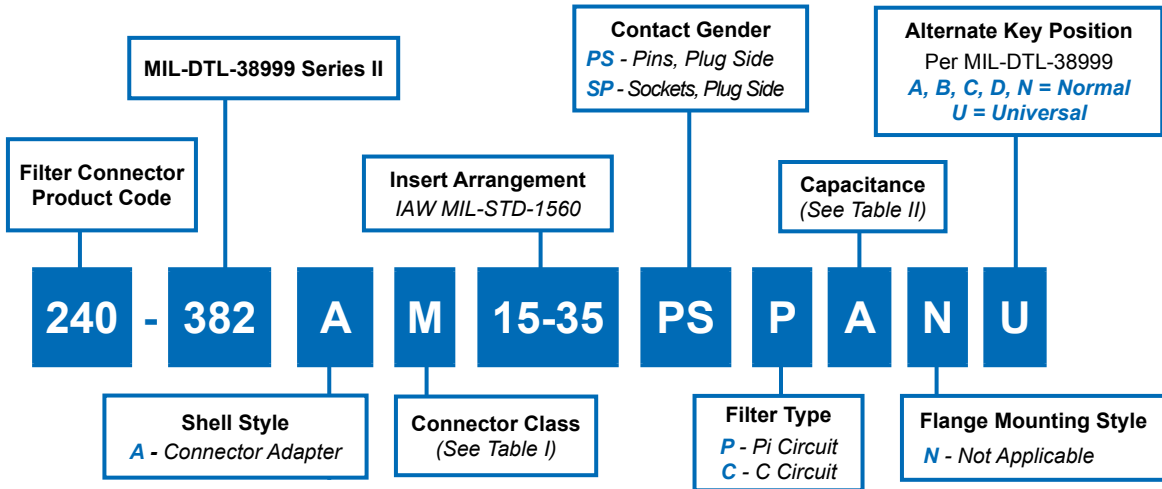

A - Connector Adapter

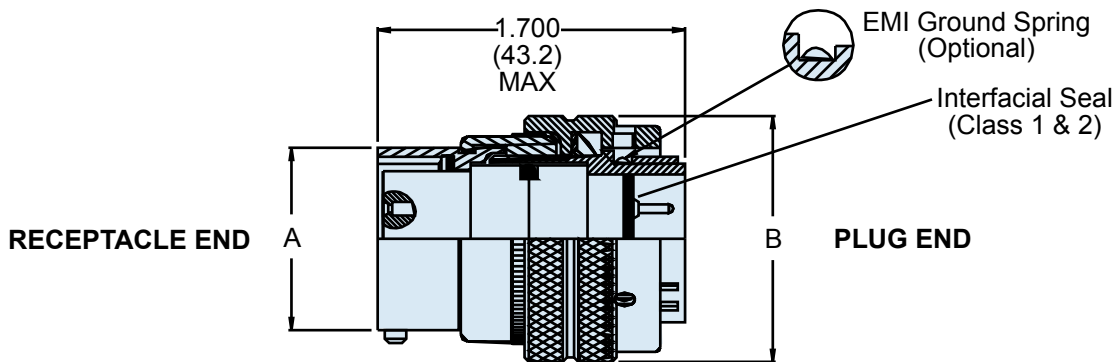

* Please consult factory for Pin/Pin and/or Socket/Socket contact arrangements.

240-382A
MIL-DTL-38999 Series II Filter Connector
Connector Adapter

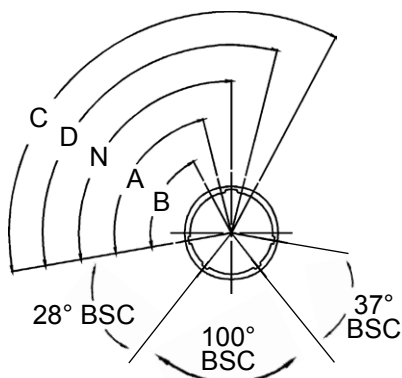

TABLE I: CONNECTOR CLASS

SYM	CLASS	MATERIAL	FINISH DESCRIPTION
M	Environmental	Aluminum	Electroless Nickel
MT	Environmental	Aluminum	Ni-PTFE 1000 Hour Grey™ Nickel Fluorocarbon Polymer
NF	Environmental	Aluminum	Cadmium O.D. Over Electroless Nickel
P	Environmental	Stainless Steel	Electro-Deposited Nickel
ZN	Environmental	Aluminum	Zinc-Nickel Over Electroless Nickel

SHELL DIAMETER

Shell Size	A Max	B Max
08	.474 (12.0)	.750 (19.1)
10	.591 (15.0)	.859 (21.8)
12	.751 (19.1)	1.031 (26.2)
14	.875 (22.2)	1.156 (29.4)
16	1.001 (25.4)	1.281 (32.5)
18	1.126 (28.6)	1.391 (35.3)
20	1.251 (31.8)	1.531 (38.9)
22	1.376 (35.0)	1.656 (42.1)
24	1.501 (38.1)	1.777 (45.1)

TABLE II: CAPACITOR ARRAY CODE
CAPACITANCE RANGE

CLASS	PI - CIRCUIT (pF)	C - CIRCUIT (pF)
X*	160,000 - 240,000	80,000 - 120,000
Y*	80,000 - 120,000	40,000 - 60,000
Z*	60,000 - 90,000	30,000 - 45,000
A	38,000 - 56,000	19,000 - 28,000
B	32,000 - 45,000	16,000 - 22,500
C	18,000 - 33,000	9,000 - 16,500
D	8,000 - 12,000	4,000 - 6,000
E	3,300 - 5,000	1,650 - 2,500
F	800 - 1,300	400 - 650
G	400 - 600	200 - 300

Consult Factory for
Additional Filter Types,
TVS Diodes, and other
Custom Filter Connector
Configurations.

MASTER KEY POSITION

NORMAL	A°	B°	C°	D°
100°	79°	66°	134°	121°

* Reduced DWV – Please consult factory.



Glenair MIL-DTL-38999 Series III Type Filter Connector with Threaded Coupling Master How to Order • Part Number Breakdown

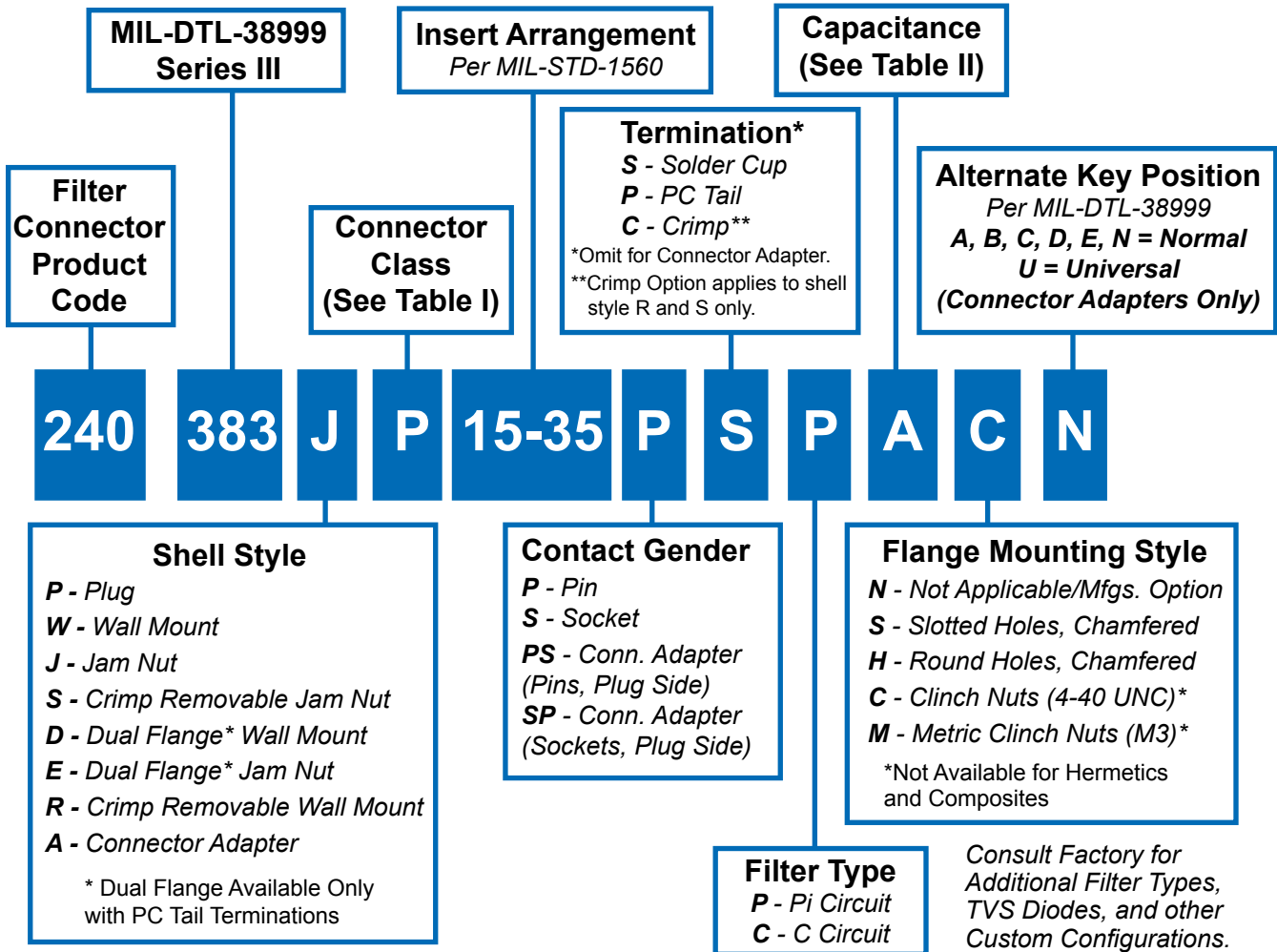

TABLE II: CAPACITOR ARRAY CODE CAPACITANCE RANGE

CLASS	PI - CIRCUIT (pF)	C - CIRCUIT (pF)
X*	160,000 - 240,000	80,000 - 120,000
Y*	80,000 - 120,000	40,000 - 60,000
Z*	60,000 - 90,000	30,000 - 45,000
A	38,000 - 56,000	19,000 - 28,000
B	32,000 - 45,000	16,000 - 22,500
C	18,000 - 33,000	9,000 - 16,500
D	8,000 - 12,000	4,000 - 6,000
E	3,300 - 5,000	1,650 - 2,500
F	800 - 1,300	400 - 650
G	400 - 600	200 - 300

* Reduced DWV – Please consult factory.

TABLE I: CONNECTOR CLASS

SYM	CLASS	MATERIAL	FINISH DESCRIPTION
M	Environmental	Aluminum	Electroless Nickel
MT	Environmental	Aluminum	Nickel Fluorocarbon Polymer (Ni-PTFE)
NF	Environmental	Aluminum	Cad. O.D. Over Electroless Nickel
P	Environmental	Stainless	Electro-Deposited Nickel
XM	Environmental	Composite	Electroless Nickel
XMT	Environmental	Composite	Nickel Fluorocarbon Polymer (Ni-PTFE)
XW	Environmental	Composite	Cad. O.D. Over Electroless Nickel
ZN	Environmental	Aluminum	Zinc-Nickel Over Electroless Nickel
H2*	Hermetic	Stainless	Electroless Nickel

* Some dimensions do not apply, see sales drawing 240-383JH2

Glenair MIL-DTL-38999 Series III Type Filter Connector with Threaded Coupling Reference Information

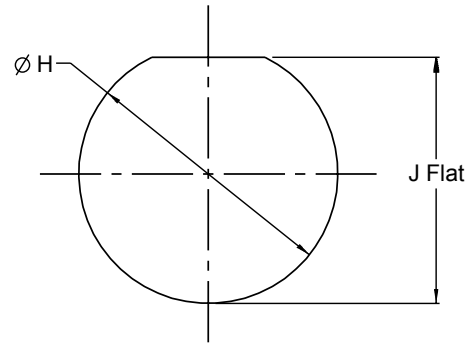
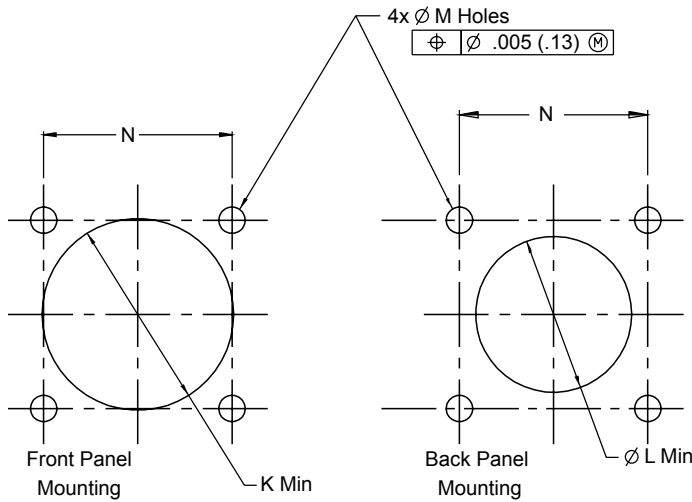

MIL-DTL-38999 Series III Square Flange Panel Cutouts					
Shell Size Code	Shell Size	ø K Min	ø L Min	M Holes	N BSC
A	09	.656 (16.7)	.516 (13.1)	.133 (3.4) .123 (3.1)	.719 (18.3)
B	11	.796 (20.2)	.625 (15.9)	.133 (3.4) .123 (3.1)	.812 (20.6)
C	13	.922 (23.4)	.750 (19.1)	.133 (3.4) .123 (3.1)	.906 (23.0)
D	15	1.047 (26.6)	.906 (23.0)	.133 (3.4) .123 (3.1)	.969 (24.6)
E	17	1.219 (31.0)	1.016 (25.8)	.133 (3.4) .123 (3.1)	1.062 (27.0)
F	19	1.297 (32.9)	1.141 (29.0)	.133 (3.4) .123 (3.1)	1.156 (29.4)
G	21	1.422 (36.1)	1.266 (32.2)	.133 (3.4) .123 (3.1)	1.250 (31.8)
H	23	1.547 (39.3)	1.375 (34.9)	.159 (4.0) .149 (3.8)	1.375 (34.9)
J	25	1.672 (42.5)	1.484 (37.7)	.155 (3.9) .145 (3.7)	1.500 (38.1)

MIL-DTL-38999 Series III Jam Nut Panel Cutout			
SHELL SIZE CODE	SHELL SIZE	ø H	J
A	09	.710 (18.0) .700 (17.8)	.670 (17.0) .660 (16.8)
B	11	.835 (21.2) .825 (21.0)	.771 (19.6) .761 (19.3)
C	13	1.020 (25.9) 1.010 (25.7)	.955 (24.3) .945 (24.0)
D	15	1.145 (29.1) 1.135 (28.8)	1.085 (27.6) 1.075 (27.3)
E	17	1.270 (32.3) 1.260 (32.0)	1.210 (30.7) 1.200 (30.5)
F	19	1.395 (35.4) 1.385 (35.2)	1.335 (33.9) 1.325 (33.7)
G	21	1.520 (38.6) 1.510 (38.4)	1.460 (37.1) 1.450 (36.8)
H	23	1.645 (41.8) 1.635 (41.5)	1.585 (40.3) 1.575 (40.0)
J	25	1.770 (45.0) 1.760 (44.7)	1.710 (43.4) 1.700 (43.2)

APPLICATION NOTES

- Materials/Finishes: Shells, Barrel, Coupling Nut, Jam Nut - See Table I
Insulators - high grade rigid dielectric/N.A.
Seals - Fluorosilicone
PC Tail & Solder Cup contacts: 50µ" Gold over 50µ" Nickel
- Assembly to be identified with Glenair's name, part number, and date code - space permitting.
- Insert Arrangement in accordance with MIL-STD-1560.
(Arrangement shown for reference only)
- EMI Circular Filter Receptacle connector designed to meet requirements of MIL-STD-2120 and MIL-DTL-38999, Series III.
- All contacts to have identical filter value. Other filter arrangements available, contact factory.
- Electrical Ratings: DWW- 500 VDC; Standard Operating Voltage 200 Volts DC; Current Rating 5 Amps (size 22);
- Insulation Resistance: 5000 MegOhms Min. at 200 VDC.
- Operating Temperature -55°C to +125°C (Env Class Connectors)
- Other filter styles (C-L, L-C, Unbalanced PI, Multi-Stage, Multi-Value) are available, please consult the factory.
- Metric Dimensions (mm) are indicated in parentheses.

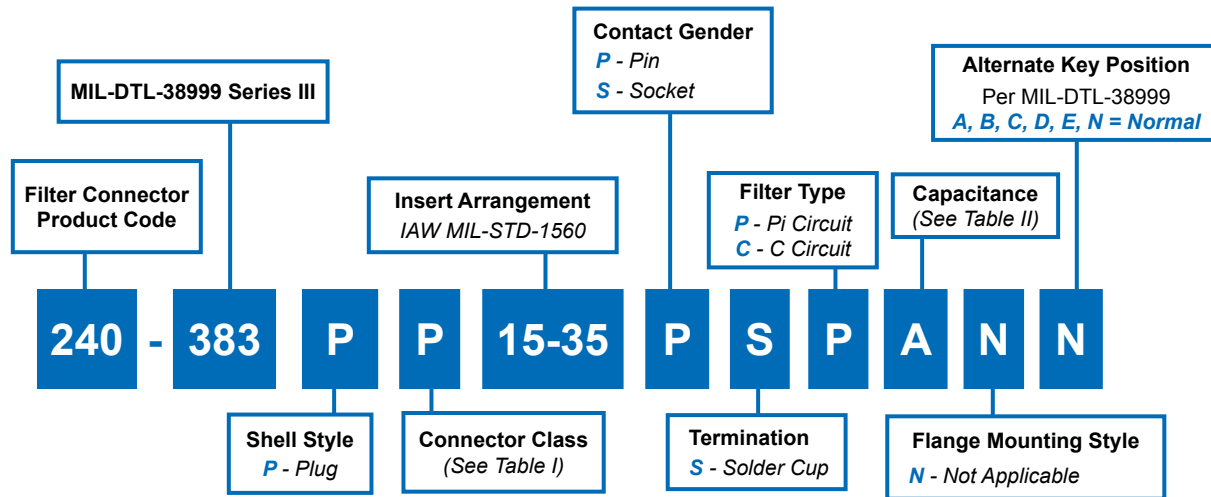

C

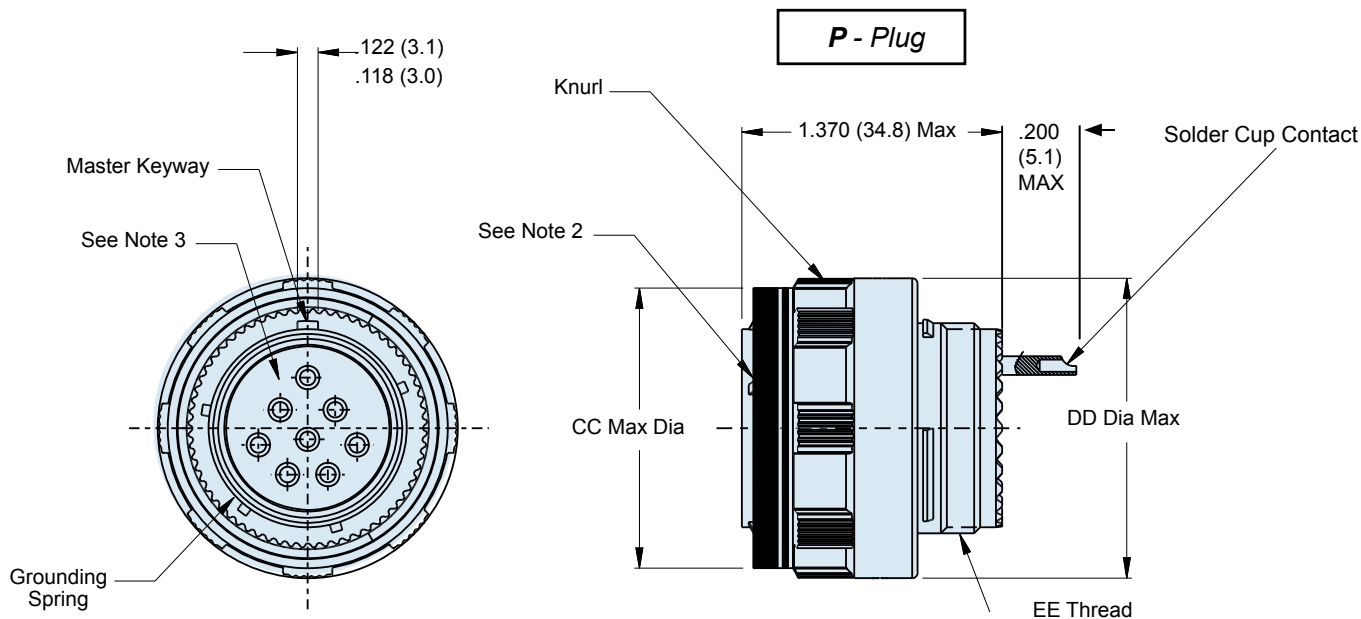

240-383P
MIL-DTL-38999 Series III Filter Connector
Plug Receptacle



TABLE I: CONNECTOR CLASS

SYM	CLASS	MATERIAL	FINISH DESCRIPTION
M	Environmental	Aluminum	Electroless Nickel
MT	Environmental	Aluminum	Nickel Fluorocarbon Polymer (Ni-PTFE)
NF	Environmental	Aluminum	Cad. O.D. Over Electroless Nickel
P	Environmental	Stainless	Electro-Deposited Nickel
XM	Environmental	Composite	Electroless Nickel
XMT	Environmental	Composite	Nickel Fluorocarbon Polymer (Ni-PTFE)
XW	Environmental	Composite	Cad. O.D. Over Electroless Nickel
ZN	Environmental	Aluminum	Zinc-Nickel Over Electroless Nickel
H2*	Hermetic	Stainless	Electroless Nickel

* Some dimensions do not apply, see sales drawing 240-383JH2

TABLE II: CAPACITOR ARRAY CODE CAPACITANCE RANGE

CLASS	PI - CIRCUIT (pF)	C - CIRCUIT (pF)
X*	160,000 - 240,000	80,000 - 120,000
Y*	80,000 - 120,000	40,000 - 60,000
Z*	60,000 - 90,000	30,000 - 45,000
A	38,000 - 56,000	19,000 - 28,000
B	32,000 - 45,000	16,000 - 22,500
C	18,000 - 33,000	9,000 - 16,500
D	8,000 - 12,000	4,000 - 6,000
E	3,300 - 5,000	1,650 - 2,500
F	800 - 1,300	400 - 650
G	400 - 600	200 - 300

* Reduced DWV – Please consult factory.

DIMENSIONS

SHELL SIZE CODE	SHELL SIZE	CC Dia Max	DD Dia Max	EE THREAD
B	11	.929 (23.6)	.984 (25.0)	M15 X 1.0-6g 0.100R
C	13	1.110 (28.2)	1.157 (29.4)	M18 X 1.0-6g 0.100R
D	15	1.232 (31.3)	1.280 (32.5)	M22 X 1.0-6g 0.100R
E	17	1.358 (34.5)	1.406 (35.7)	M25 X 1.0-6g 0.100R
F	19	1.469 (37.3)	1.516 (38.5)	M28 X 1.0-6g 0.100R
G	21	1.594 (40.5)	1.642 (41.7)	M31 X 1.0-6g 0.100R
H	23	1.720 (43.7)	1.768 (44.9)	M34 X 1.0-6g 0.100R
J	25	1.843 (46.8)	1.890 (48.0)	M37 X 1.0-6g 0.100R

*Consult Factory for
 Additional Filter Types,
 TVS Diodes, and other
 Custom Configurations.*

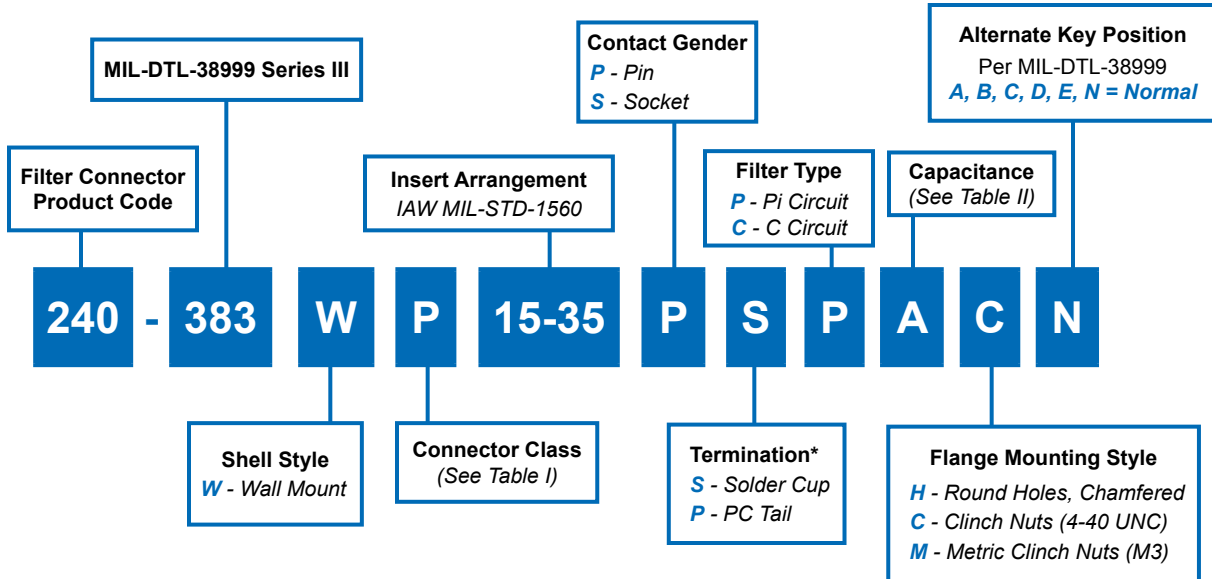

Clinch Nuts and Metric Clinch Nuts Not Available for Composites.
Helicoils and Threaded Inserts/Specials Available Upon Request.

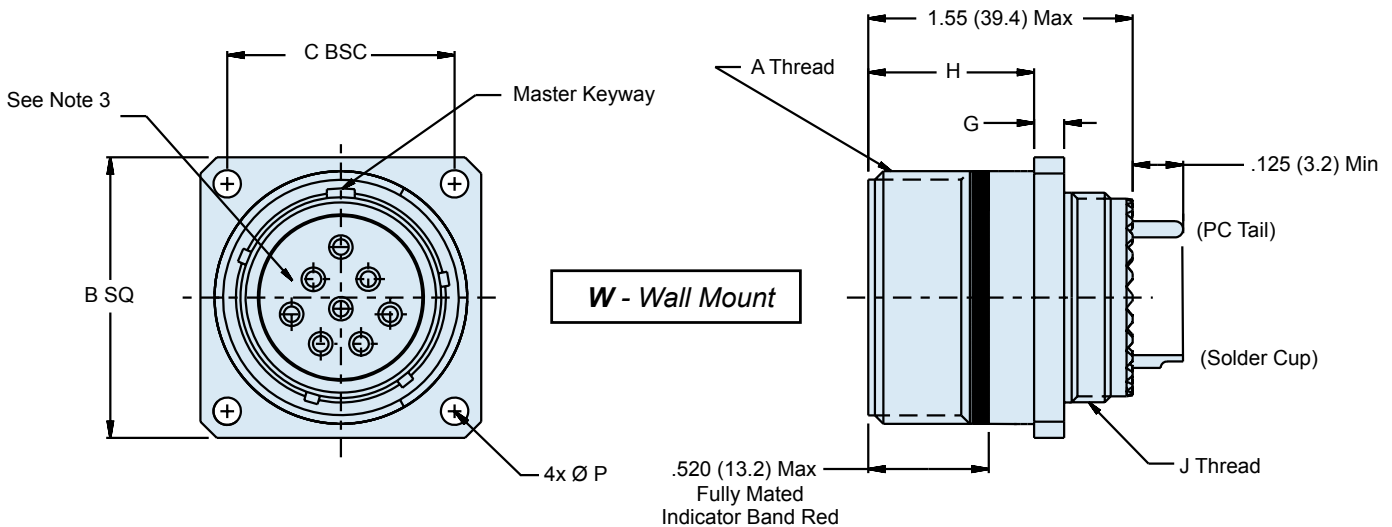

Consult Factory for
Alternative PC Tail
Lengths

240-383W MIL-DTL-38999 Series III Filter Connector Wall Mount Receptacle



EMI/EMP
Filters

TABLE I: CONNECTOR CLASS

SYM	CLASS	MATERIAL	FINISH DESCRIPTION
M	Environmental	Aluminum	Electroless Nickel
MT	Environmental	Aluminum	Nickel Fluorocarbon Polymer (Ni-PTFE)
NF	Environmental	Aluminum	Cad. O.D. Over Electroless Nickel
P	Environmental	Stainless	Electro-Deposited Nickel
XM	Environmental	Composite	Electroless Nickel
XMT	Environmental	Composite	Nickel Fluorocarbon Polymer (Ni-PTFE)
XW	Environmental	Composite	Cad. O.D. Over Electroless Nickel
ZN	Environmental	Aluminum	Zinc-Nickel Over Electroless Nickel
H2*	Hermetic	Stainless	Electroless Nickel

* Some dimensions do not apply, see sales drawing 240-383JH2

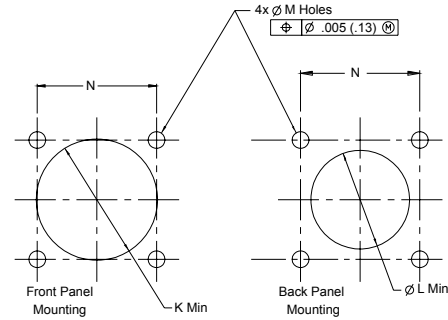

**TABLE II: CAPACITOR ARRAY CODE
CAPACITANCE RANGE**

CLASS	PI - CIRCUIT (pF)	C - CIRCUIT (pF)
X*	160,000 - 240,000	80,000 - 120,000
Y*	80,000 - 120,000	40,000 - 60,000
Z*	60,000 - 90,000	30,000 - 45,000
A	38,000 - 56,000	19,000 - 28,000
B	32,000 - 45,000	16,000 - 22,500
C	18,000 - 33,000	9,000 - 16,500
D	8,000 - 12,000	4,000 - 6,000
E	3,300 - 5,000	1,650 - 2,500
F	800 - 1,300	400 - 650
G	400 - 600	200 - 300

* Reduced DWV – Please consult factory.

**MIL-DTL-38999 Series III
Square Flange Panel Cutouts**

Shell Size Code	Shell Size	Ø K Min	Ø L Min	M Holes	N BSC	P Ø ± .010
A	09	.656 (16.7)	.516 (13.1)	.133 (3.4) .123 (3.1)	.719 (18.3)	.128 (3.3)
B	11	.796 (20.2)	.625 (15.9)	.133 (3.4) .123 (3.1)	.812 (20.6)	
C	13	.922 (23.4)	.750 (19.1)	.133 (3.4) .123 (3.1)	.906 (23.0)	
D	15	1.047 (26.6)	.906 (23.0)	.133 (3.4) .123 (3.1)	.969 (24.6)	
E	17	1.219 (31.0)	1.016 (25.8)	.133 (3.4) .123 (3.1)	1.062 (27.0)	
F	19	1.297 (32.9)	1.141 (29.0)	.133 (3.4) .123 (3.1)	1.156 (29.4)	
G	21	1.422 (36.1)	1.266 (32.2)	.133 (3.4) .123 (3.1)	1.250 (31.8)	
H	23	1.547 (39.3)	1.375 (34.9)	.159 (4.0) .149 (3.8)	1.375 (34.9)	
J	25	1.672 (42.5)	1.484 (37.7)	.155 (3.9) .145 (3.7)	1.500 (38.1)	

WALL MOUNT

SHELL SIZE CODE	SHELL SIZE	A THREAD	B SQ	C BSC	D BSC	E	F	G	H	J THREAD	
A	09	.6250-.1P-.3L-TS-2A	0.949 (24.1) 0.925 (23.5)	.719 (18.3)	.594 (15.1)	.136 (3.5) .120 (3.0)	.224 (5.7) .208 (5.3)	.143 (3.6) .083 (2.1)	.820 (20.8) .771 (19.6)	M12 X 1.0-6g 0.100R	
B	11	.7500-.1P-.3L-TS-2A	1.043 (26.5) 1.019 (25.9)	.812 (20.6)	.719 (18.3)	.136 (3.5) .120 (3.0)	.202 (5.1) .186 (4.7)		.820 (20.8) .771 (19.6)	M15 X 1.0-6g 0.100R	
C	13	.8750-.1P-.3L-TS-2A	1.138 (28.9) 1.114 (28.3)	.906 (23.0)	.812 (20.6)	.136 (3.5) .120 (3.0)	.202 (5.1) .186 (4.7)		.820 (20.8) .771 (19.6)	M18 X 1.0-6g 0.100R	
D	15	1.000-.1P-.3L-TS-2A	1.232 (31.3) 1.208 (30.7)	.969 (24.6)	.906 (23.0)	.136 (3.5) .120 (3.0)	.202 (5.1) .165 (4.2)		.820 (20.8) .771 (19.6)	M22 X 1.0-6g 0.100R	
E	17	1.1875-.1P-.3L-TS-2A	1.323 (33.6) 1.299 (33.0)	1.062 (27.0)	.969 (24.6)	.136 (3.5) .120 (3.0)	.202 (5.1) .186 (4.7)		.820 (20.8) .771 (19.6)	M25 X 1.0-6g 0.100R	
F	19	1.2500-.1P-.3L-TS-2A	1.449 (36.8) 1.425 (36.2)	1.156 (29.4)	1.062 (27.0)	.136 (3.5) .120 (3.0)	.202 (5.1) .186 (4.7)		.820 (20.8) .771 (19.6)	M28 X 1.0-6g 0.100R	
G	21	1.3750-.1P-.3L-TS-2A	1.575 (40.0) 1.551 (39.4)	1.250 (31.8)	1.156 (29.4)	.136 (3.5) .120 (3.0)	.202 (5.1) .186 (4.7)		.790 (20.1) .741 (18.8)	M31 X 1.0-6g 0.100R	
H	23	1.5000-.1P-.3L-TS-2A	1.701 (43.2) 1.677 (42.6)	1.375 (34.9)	1.250 (31.8)	.162 (4.1) .146 (3.7)	.250 (6.4) .234 (5.9)		.171 (4.3) .083 (2.1)	.790 (20.1) .741 (18.8)	M34 X 1.0-6g 0.100R
J	25	1.6250-.1P-.3L-TS-2A	1.823 (46.3) 1.799 (45.7)	1.500 (38.1)	1.375 (34.9)	.162 (4.1) .146 (3.7)	.250 (6.4) .234 (5.9)		.790 (20.1) .741 (18.8)	M37 X 1.0-6g 0.100R	

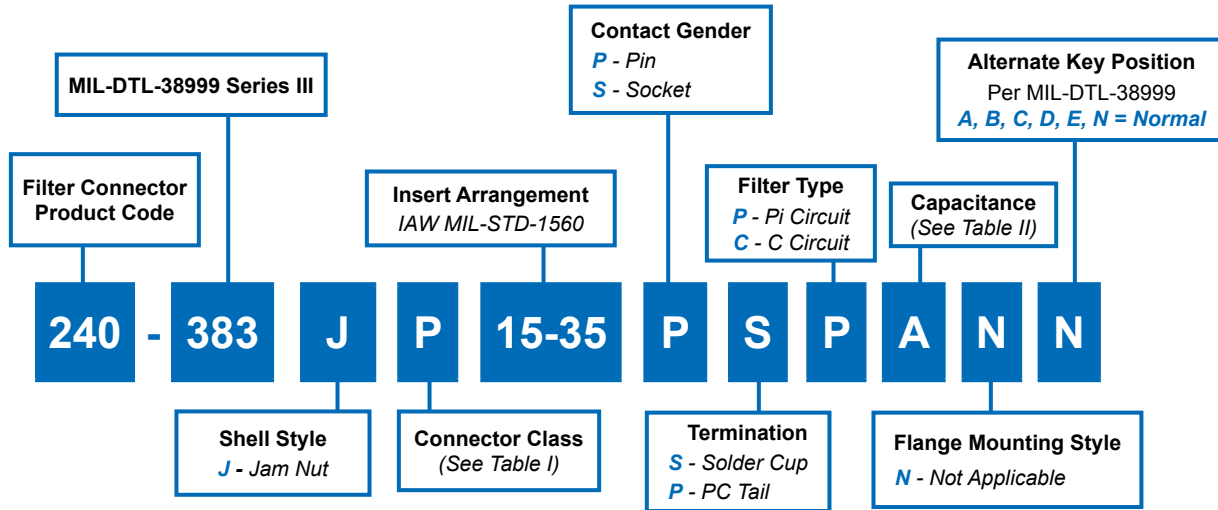

C

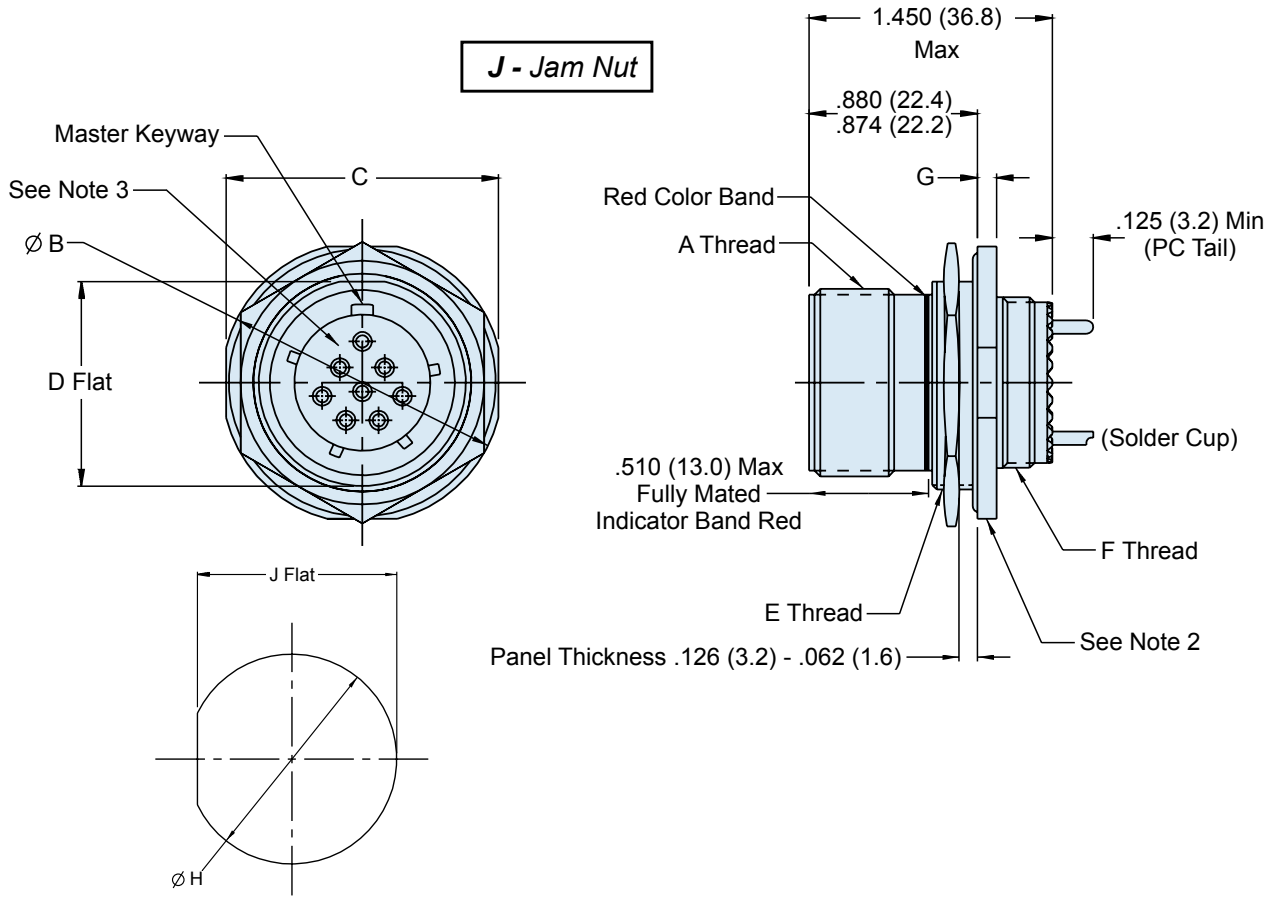

240-383J MIL-DTL-38999 Series III Filter Connector Jam Nut Receptacle



TABLE I: CONNECTOR CLASS

SYM	CLASS	MATERIAL	FINISH DESCRIPTION
M	Environmental	Aluminum	Electroless Nickel
MT	Environmental	Aluminum	Nickel Fluorocarbon Polymer (Ni-PTFE)
NF	Environmental	Aluminum	Cad. O.D. Over Electroless Nickel
P	Environmental	Stainless	Electro-Deposited Nickel
XM	Environmental	Composite	Electroless Nickel
XMT	Environmental	Composite	Nickel Fluorocarbon Polymer (Ni-PTFE)
XW	Environmental	Composite	Cad. O.D. Over Electroless Nickel
ZN	Environmental	Aluminum	Zinc-Nickel Over Electroless Nickel
H2*	Hermetic	Stainless	Electroless Nickel

* Some dimensions do not apply, see sales drawing 240-383JH2

**TABLE II: CAPACITOR ARRAY CODE
CAPACITANCE RANGE**

CLASS	PI - CIRCUIT (pF)	C - CIRCUIT (pF)
X*	160,000 - 240,000	80,000 - 120,000
Y*	80,000 - 120,000	40,000 - 60,000
Z*	60,000 - 90,000	30,000 - 45,000
A	38,000 - 56,000	19,000 - 28,000
B	32,000 - 45,000	16,000 - 22,500
C	18,000 - 33,000	9,000 - 16,500
D	8,000 - 12,000	4,000 - 6,000
E	3,300 - 5,000	1,650 - 2,500
F	800 - 1,300	400 - 650
G	400 - 600	200 - 300

* Reduced DWV – Please consult factory.

**MIL-DTL-38999 Series III
Jam Nut Panel Cutout**

SHELL SIZE CODE	SHELL SIZE	Ø H	J
A	09	.710 (18.0)	.670 (17.0)
		.700 (17.8)	.660 (16.8)
B	11	.835 (21.2)	.771 (19.6)
		.825 (21.0)	.761 (19.3)
C	13	1.020 (25.9)	.955 (24.3)
		1.010 (25.7)	.945 (24.0)
D	15	1.145 (29.1)	1.085 (27.6)
		1.135 (28.8)	1.075 (27.3)
E	17	1.270 (32.3)	1.210 (30.7)
		1.260 (32.0)	1.200 (30.5)
F	19	1.395 (35.4)	1.335 (33.9)
		1.385 (35.2)	1.325 (33.7)
G	21	1.520 (38.6)	1.460 (37.1)
		1.510 (38.4)	1.450 (36.8)
H	23	1.645 (41.8)	1.585 (40.3)
		1.635 (41.5)	1.575 (40.0)
J	25	1.770 (45.0)	1.710 (43.4)
		1.760 (44.7)	1.700 (43.2)

*Consult Factory for
Additional Filter Types,
TVS Diodes, and other
Custom Configurations.*

JAM NUT MOUNT

SHELL SIZE CODE	SHELL SIZE	A THREAD	Ø B	C	D	E THREAD	F THREAD	G
A	09	.6250- .1P- .3L-TS-2A	1.262 (32.1)	1.079 (27.4)	.655 (16.6)	M17 X 1.0-6g 0.100R	M12 X 1.0-6g 0.100R	.122 (3.1)
			1.177 (29.9)	1.047 (26.6)	.645 (16.4)			.083 (2.1)
B	11	.7500- .1P- .3L-TS-2A	1.386 (35.2)	1.268 (32.2)	.755 (19.2)	M20 X 1.0-6g 0.100R	M15 X 1.0-6g 0.100R	.122 (3.1)
			1.362 (34.6)	1.236 (31.4)	.745 (18.9)			.083 (2.1)
C	13	.8750- .1P- .3L-TS-2A	1.512 (38.4)	1.390 (35.3)	.942 (23.9)	M25 X 1.0-6g 0.100R	M18 X 1.0-6g 0.100R	.122 (3.1)
			1.488 (37.8)	1.358 (34.5)	.932 (23.7)			.083 (2.1)
D	15	1.000- .1P- .3L-TS-2A	1.638 (41.6)	1.516 (38.5)	1.068 (27.1)	M28 X 1.0-6g 0.100R	M22 X 1.0-6g 0.100R	.122 (3.1)
			1.614 (41.0)	1.484 (37.7)	1.058 (26.8)			.083 (2.1)
E	17	1.1875- .1P- .3L-TS-2A	1.764 (44.8)	1.642 (41.7)	1.191 (30.3)	M32 X 1.0-6g 0.100R	M25 X 1.0-6g 0.100R	.122 (3.1)
			1.740 (44.2)	1.610 (40.9)	1.181 (30.0)			.083 (2.1)
F	19	1.2500- .1P- .3L-TS-2A	1.949 (49.5)	1.827 (46.4)	1.316 (33.4)	M35 X 1.0-6g 0.100R	M28 X 1.0-6g 0.100R	.154 (3.9)
			1.925 (48.9)	1.795 (45.6)	1.306 (33.2)			.114 (2.9)
G	21	1.3750- .1P- .3L-TS-2A	2.075 (52.7)	1.953 (49.6)	1.441 (36.6)	M38 X 1.0-6g 0.100R	M31 X 1.0-6g 0.100R	.154 (3.9)
			2.051 (52.1)	1.921 (48.8)	1.431 (36.3)			.114 (2.9)
H	23	1.5000- .1P- .3L-TS-2A	2.201 (55.9)	2.079 (52.8)	1.566 (39.8)	M41 X 1.0-6g 0.100R	M34 X 1.0-6g 0.100R	.154 (3.9)
			2.177 (55.3)	2.047 (52.0)	1.556 (39.5)			.114 (2.9)
J	25	1.6250- .1P- .3L-TS-2A	2.323 (59.0)	2.205 (56.0)	1.691 (43.0)	M44 X 1.0-6g 0.100R	M37 X 1.0-6g 0.100R	.154 (3.9)
			2.299 (58.4)	2.173 (55.2)	1.681 (42.7)			.114 (2.9)

240-383S MIL-DTL-38999 Series III Filter Connector Jam Nut Receptacle with Crimp Removable Socket Contacts

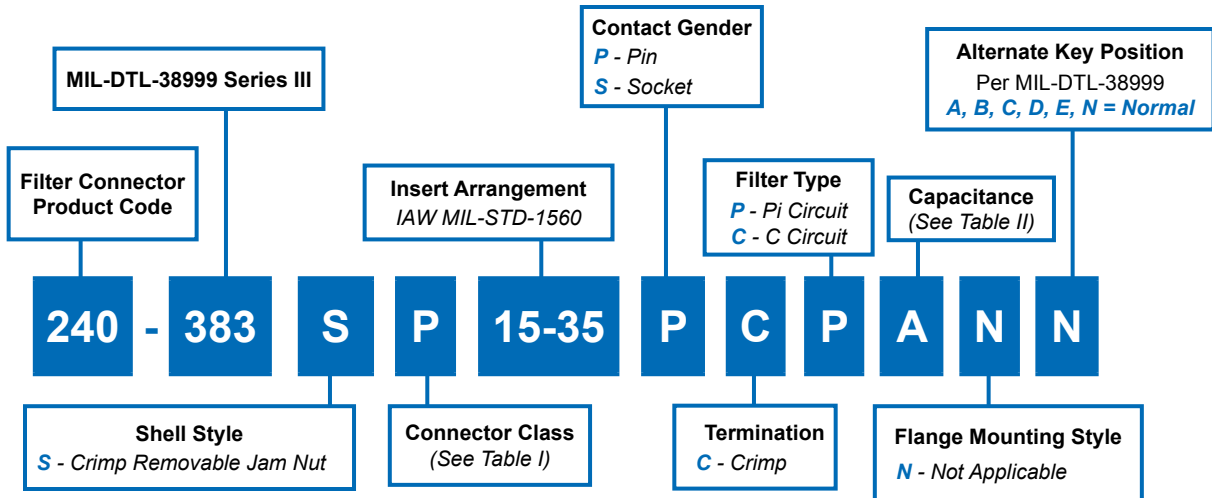

NOTE: Crimp removable socket contacts to conform to MIL-C-39029/57-358, Size 16, MIL-C-39029/57-357 Size 20, and MIL-C-39029/57-354 Size 22D (Supplied loose).

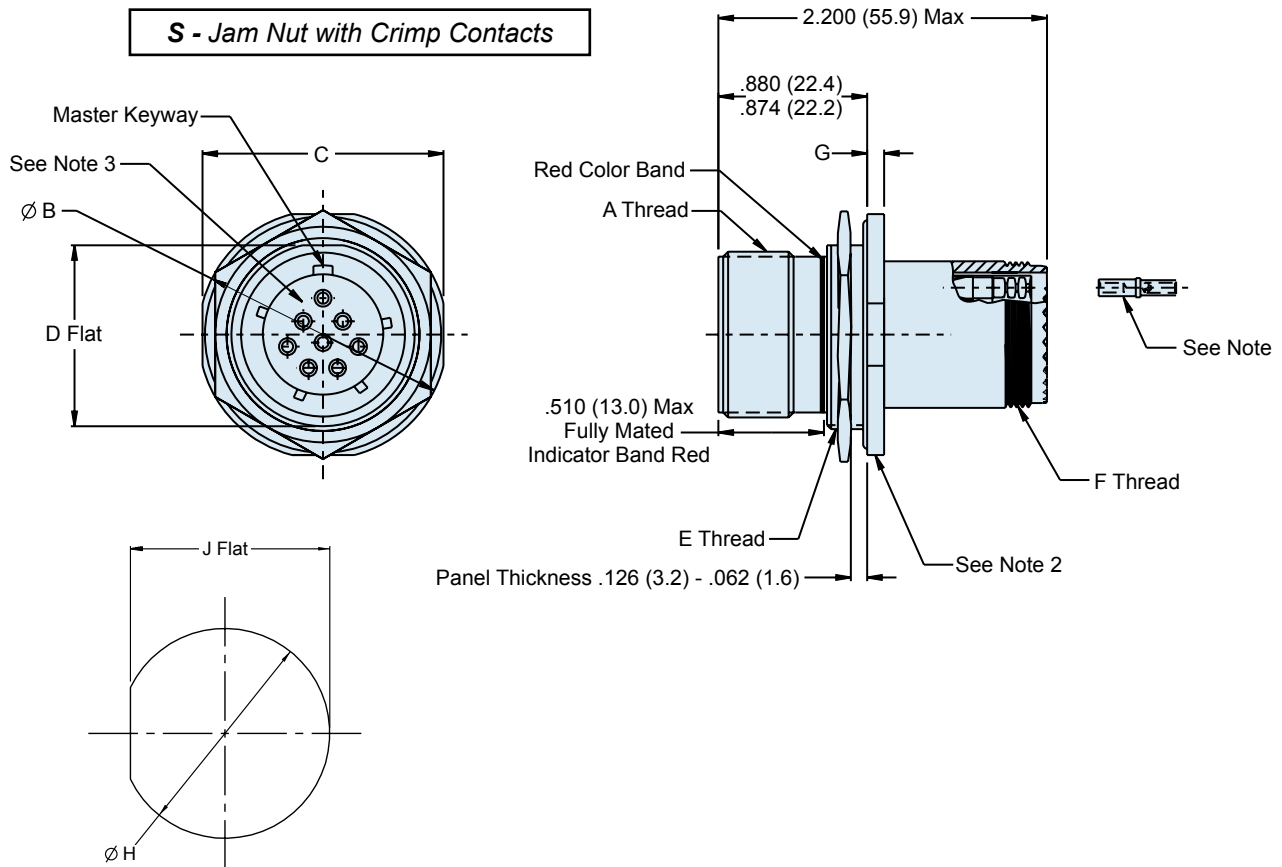

240-383S
MIL-DTL-38999 Series III Filter Connector
Jam Nut Receptacle
with Crimp Removable Socket Contacts



TABLE I: CONNECTOR CLASS

SYM	CLASS	MATERIAL	FINISH DESCRIPTION
M	Environmental	Aluminum	Electroless Nickel
MT	Environmental	Aluminum	Nickel Fluorocarbon Polymer (Ni-PTFE)
NF	Environmental	Aluminum	Cad. O.D. Over Electroless Nickel
P	Environmental	Stainless	Electro-Deposited Nickel
XM	Environmental	Composite	Electroless Nickel
XMT	Environmental	Composite	Nickel Fluorocarbon Polymer (Ni-PTFE)
XW	Environmental	Composite	Cad. O.D. Over Electroless Nickel
ZN	Environmental	Aluminum	Zinc-Nickel Over Electroless Nickel
H2*	Hermetic	Stainless	Electroless Nickel

* Some dimensions do not apply, see sales drawing 240-383JH2

TABLE II: CAPACITOR ARRAY CODE CAPACITANCE RANGE

CLASS	PI - CIRCUIT (pF)	C - CIRCUIT (pF)
X*	160,000 - 240,000	80,000 - 120,000
Y*	80,000 - 120,000	40,000 - 60,000
Z*	60,000 - 90,000	30,000 - 45,000
A	38,000 - 56,000	19,000 - 28,000
B	32,000 - 45,000	16,000 - 22,500
C	18,000 - 33,000	9,000 - 16,500
D	8,000 - 12,000	4,000 - 6,000
E	3,300 - 5,000	1,650 - 2,500
F	800 - 1,300	400 - 650
G	400 - 600	200 - 300

* Reduced DWV – Please consult factory.

**MIL-DTL-38999 Series III
Jam Nut Panel Cutout**

SHELL SIZE CODE	SHELL SIZE	Ø H	J
A	09	.710 (18.0)	.670 (17.0)
		.700 (17.8)	.660 (16.8)
B	11	.835 (21.2)	.771 (19.6)
		.825 (21.0)	.761 (19.3)
C	13	1.020 (25.9)	.955 (24.3)
		1.010 (25.7)	.945 (24.0)
D	15	1.145 (29.1)	1.085 (27.6)
		1.135 (28.8)	1.075 (27.3)
E	17	1.270 (32.3)	1.210 (30.7)
		1.260 (32.0)	1.200 (30.5)
F	19	1.395 (35.4)	1.335 (33.9)
		1.385 (35.2)	1.325 (33.7)
G	21	1.520 (38.6)	1.460 (37.1)
		1.510 (38.4)	1.450 (36.8)
H	23	1.645 (41.8)	1.585 (40.3)
		1.635 (41.5)	1.575 (40.0)
J	25	1.770 (45.0)	1.710 (43.4)
		1.760 (44.7)	1.700 (43.2)

*Consult Factory for
Additional Filter Types,
TVS Diodes, and other
Custom Configurations.*

JAM NUT MOUNT

SHELL SIZE CODE	SHELL SIZE	A THREAD	Ø B	C	D	E THREAD	F THREAD	G
A	09	.6250-.1P-.3L-TS-2A	1.262 (32.1)	1.079 (27.4)	.655 (16.6)	M17 X 1.0-6g 0.100R	M12 X 1.0-6g 0.100R	.122 (3.1)
			1.248 (31.7)	1.047 (26.6)	.645 (16.4)			.083 (2.1)
B	11	.7500-.1P-.3L-TS-2A	1.386 (35.2)	1.268 (32.2)	.755 (19.2)	M20 X 1.0-6g 0.100R	M15 X 1.0-6g 0.100R	.122 (3.1)
			1.362 (34.6)	1.236 (31.4)	.745 (18.9)			.083 (2.1)
C	13	.8750-.1P-.3L-TS-2A	1.512 (38.4)	1.390 (35.3)	.942 (23.9)	M25 X 1.0-6g 0.100R	M18 X 1.0-6g 0.100R	.122 (3.1)
			1.488 (37.8)	1.358 (34.5)	.932 (23.7)			.083 (2.1)
D	15	1.000-.1P-.3L-TS-2A	1.638 (41.6)	1.516 (38.5)	1.068 (27.1)	M28 X 1.0-6g 0.100R	M22 X 1.0-6g 0.100R	.122 (3.1)
			1.614 (41.0)	1.484 (37.7)	1.058 (26.9)			.083 (2.1)
E	17	1.1875-.1P-.3L-TS-2A	1.764 (44.8)	1.642 (41.7)	1.191 (30.3)	M32 X 1.0-6g 0.100R	M25 X 1.0-6g 0.100R	.122 (3.1)
			1.740 (44.2)	1.610 (40.9)	1.181 (30.0)			.083 (2.1)
F	19	1.2500-.1P-.3L-TS-2A	1.949 (49.5)	1.827 (46.4)	1.316 (33.4)	M35 X 1.0-6g 0.100R	M28 X 1.0-6g 0.100R	.154 (3.9)
			1.925 (48.9)	1.795 (45.6)	1.306 (33.2)			.114 (2.9)
G	21	1.3750-.1P-.3L-TS-2A	2.075 (52.7)	1.953 (49.6)	1.441 (36.6)	M38 X 1.0-6g 0.100R	M31 X 1.0-6g 0.100R	.154 (3.9)
			2.051 (52.1)	1.921 (48.8)	1.431 (36.3)			.114 (2.9)
H	23	1.5000-.1P-.3L-TS-2A	2.201 (55.9)	2.079 (52.8)	1.566 (39.8)	M41 X 1.0-6g 0.100R	M34 X 1.0-6g 0.100R	.154 (3.9)
			2.177 (55.3)	2.047 (52.0)	1.556 (39.5)			.114 (2.9)
J	25	1.6250-.1P-.3L-TS-2A	2.323 (59.0)	2.205 (56.0)	1.691 (43.0)	M44 X 1.0-6g 0.100R	M37 X 1.0-6g 0.100R	.154 (3.9)
			2.299 (58.4)	2.173 (55.2)	1.681 (42.7)			.114 (2.9)

240-383D MIL-DTL-38999 Series III Filter Connector Dual Flange Wall Mount Receptacle with P.C.Tails

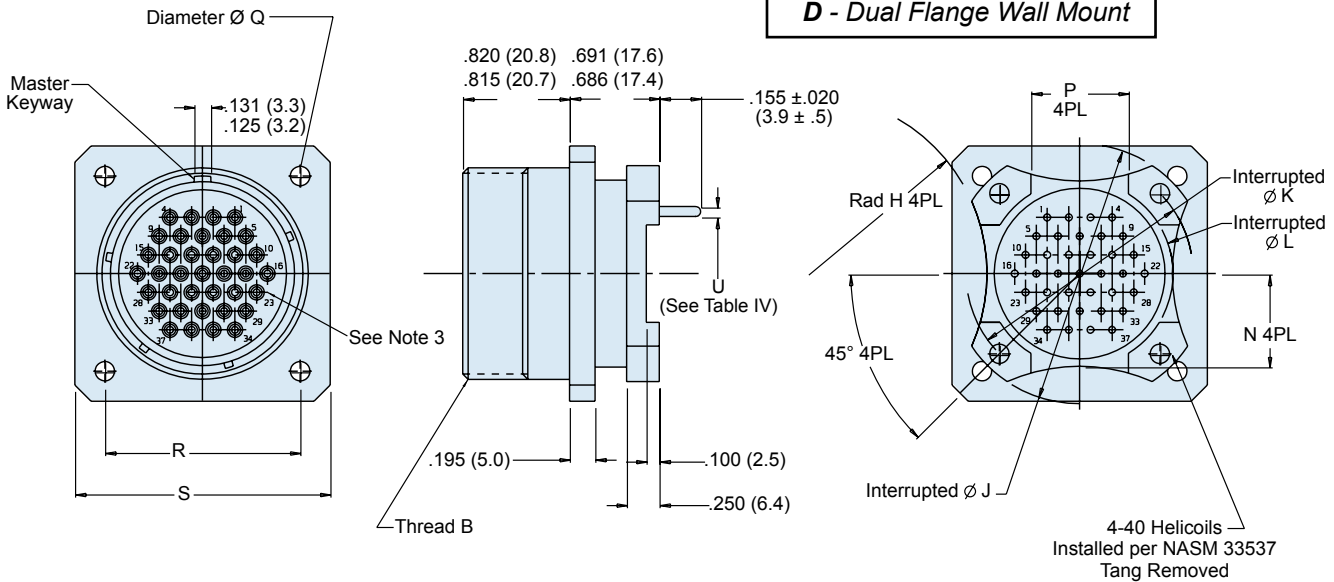
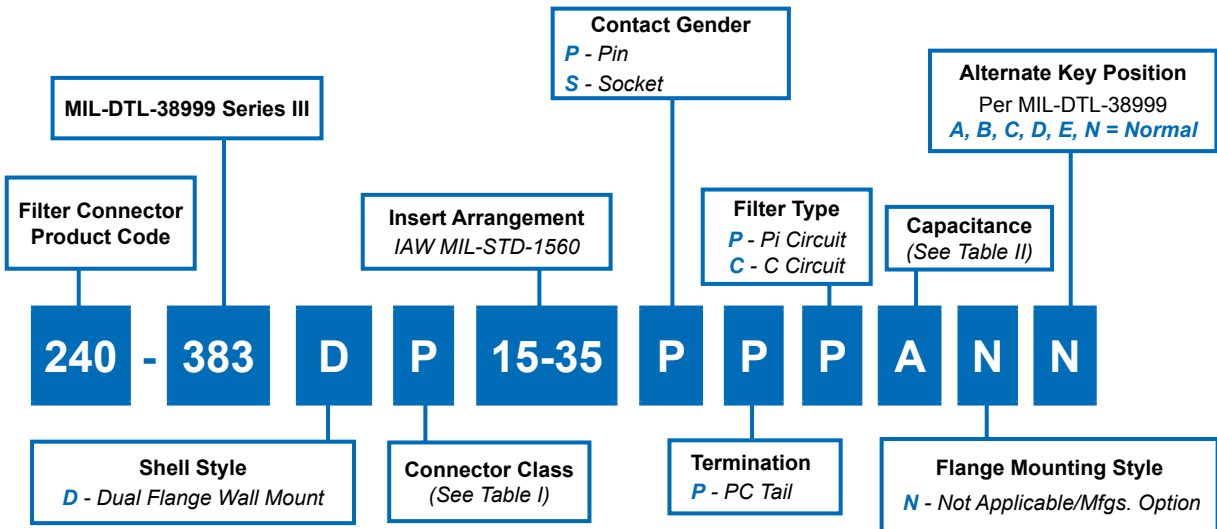

Position	A°	B°
A	150°	210°
B	75°	210°
C	95°	230°
D	140°	275°

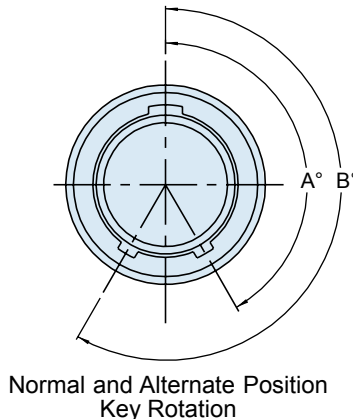

Contact Size	ØU
22D	.018/.021 (0.5/0.5)
20	.029/.031 (0.7/0.8)
16	.038/.042 (1.0/1.1)

240-383D MIL-DTL-38999 Series III Filter Connector Dual Flange Wall Mount Receptacle with P.C.Tails



TABLE I: CONNECTOR CLASS

SYM	CLASS	MATERIAL	FINISH DESCRIPTION
M	Environmental	Aluminum	Electroless Nickel
MT	Environmental	Aluminum	Nickel Fluorocarbon Polymer (Ni-PTFE)
NF	Environmental	Aluminum	Cad. O.D. Over Electroless Nickel
P	Environmental	Stainless	Electro-Deposited Nickel
XM	Environmental	Composite	Electroless Nickel
XMT	Environmental	Composite	Nickel Fluorocarbon Polymer (Ni-PTFE)
XW	Environmental	Composite	Cad. O.D. Over Electroless Nickel
ZN	Environmental	Aluminum	Zinc-Nickel Over Electroless Nickel
H2*	Hermetic	Stainless	Electroless Nickel

* Some dimensions do not apply, see sales drawing 240-383JH2

Consult Factory for Additional Filter Types, TVS Diodes, and other Custom Configurations.

TABLE II: CAPACITOR ARRAY CODE CAPACITANCE RANGE

CLASS	PI - CIRCUIT (pF)	C - CIRCUIT (pF)
X*	160,000 - 240,000	80,000 - 120,000
Y*	80,000 - 120,000	40,000 - 60,000
Z*	60,000 - 90,000	30,000 - 45,000
A	38,000 - 56,000	19,000 - 28,000
B	32,000 - 45,000	16,000 - 22,500
C	18,000 - 33,000	9,000 - 16,500
D	8,000 - 12,000	4,000 - 6,000
E	3,300 - 5,000	1,650 - 2,500
F	800 - 1,300	400 - 650
G	400 - 600	200 - 300

* Reduced DWV – Please consult factory.

TABLE III: DIMENSIONS

SHELL SIZE	B THREAD (PLATED)	P +/- .01 (.25)	R BSC	S +/- .012 (.3)	ØJ +/- .005 (.13)	ØK BSC	ØL +/- .005 (.13)	H +/- .020 (.51)	N +/- .020 (.51)	ØQ ± .010
9	.625-.1P-.3L-TS-2A	.225 (5.7)	.719 (18.3)	.937 (23.8)	1.016 (25.8)	.752 (19.1)	.532 (13.5)	.225 (5.7)	.275 (7.0)	.128 (3.3)
11	.7500-.1P-.3L-TS-2A	.250 (6.4)	.812 (20.6)	1.181 (30.0)	1.062 (27.0)	.850 (21.6)	.595 (15.1)	.250 (6.4)	.290 (7.4)	
13	.8750-.1P-.3L-TS-2A	.250 (6.4)	.906 (23.0)	1.277 (32.4)	1.250 (31.8)	.994 (25.2)	.720 (18.3)	.375 (9.5)	.370 (9.4)	
15	1.000-.1P-.3L-TS-2A	.325 (8.2)	.969 (24.6)	1.371 (34.8)	1.375 (34.9)	1.119 (28.4)	.843 (21.4)	.438 (11.1)	.440 (11.2)	
17	1.1875-.1P-.3L-TS-2A	.375 (9.5)	1.062 (27.0)	1.462 (37.1)	1.500 (38.1)	1.237 (31.4)	1.000 (25.4)	.562 (14.3)	.495 (12.6)	
19	1.2500-.1P-.3L-TS-2A	.500 (12.7)	1.156 (29.4)	1.588 (40.3)	1.625 (41.3)	1.379 (35.0)	1.125 (28.6)	.875 (22.2)	.540 (13.7)	
21	1.3750-.1P-.3L-TS-2A	.562 (14.3)	1.250 (31.8)	1.714 (43.5)	1.750 (44.5)	1.489 (37.8)	1.240 (31.5)	1.170 (29.7)	.625 (15.9)	
23	1.5000-.1P-.3L-TS-2A	.688 (17.5)	1.375 (34.9)	1.840 (46.7)	1.875 (47.6)	1.619 (41.1)	1.328 (33.7)	1.250 (31.8)	.660 (16.8)	.156 (4.0)
25	1.6250-.1P-.3L-TS-2A	.750 (19.1)	1.500 (38.1)	1.962 (49.8)	2.000 (50.8)	1.744 (44.3)	1.453 (36.9)	1.375 (34.9)	.740 (18.8)	

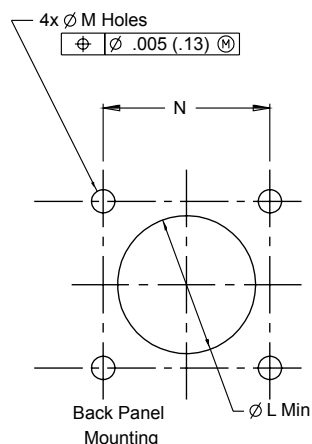

Panel Cutout Dimensions

Shell Size	Ø L Min	M Holes	N BSC
09	.516 (13.1)	.133 (3.4) .123 (3.1)	.719 (18.3)
11	.625 (15.9)	.133 (3.4) .123 (3.1)	.812 (20.6)
13	.750 (19.1)	.133 (3.4) .123 (3.1)	.906 (23.0)
15	.906 (23.0)	.133 (3.4) .123 (3.1)	.969 (24.6)
17	1.016 (25.8)	.133 (3.4) .123 (3.1)	1.062 (27.0)
19	1.141 (29.0)	.133 (3.4) .123 (3.1)	1.156 (29.4)
21	1.266 (32.2)	.133 (3.4) .123 (3.1)	1.250 (31.8)
23	1.375 (34.9)	.159 (4.0) .149 (3.8)	1.375 (34.9)
25	1.484 (37.7)	.155 (3.9) .145 (3.7)	1.500 (38.1)

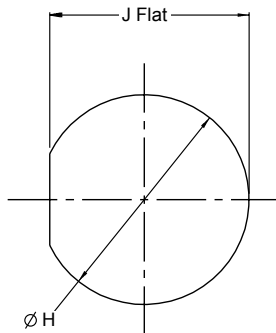
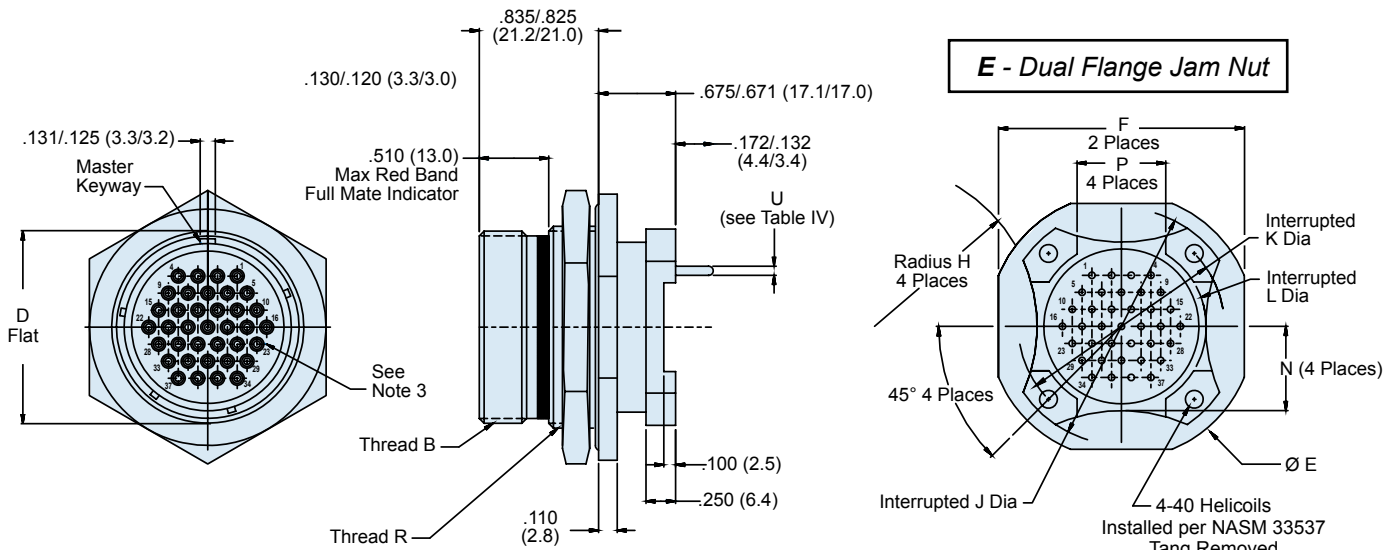
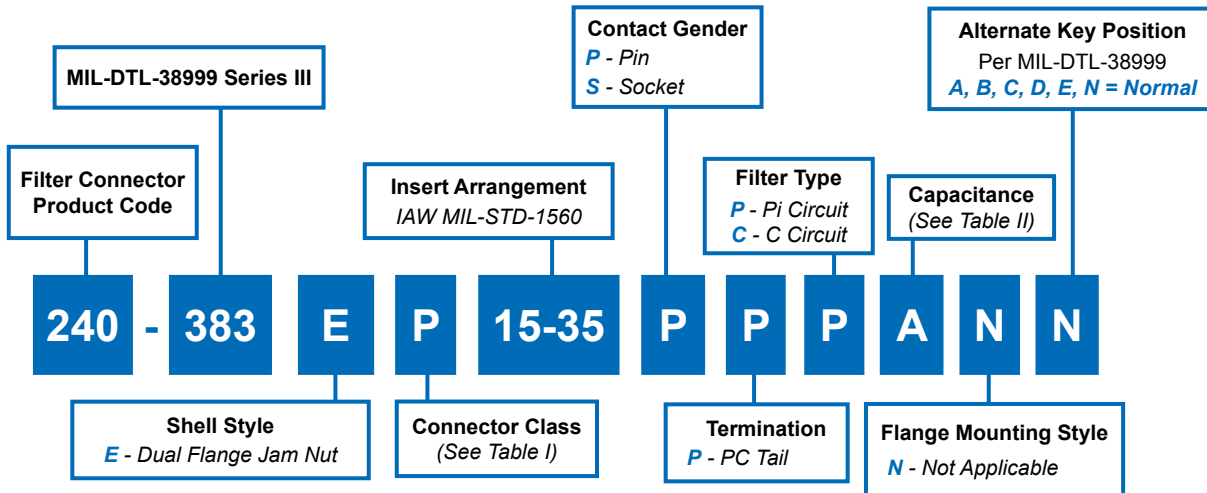

TABLE IV: PC TAIL DIAMETER	
Contact Size	Ø U
22D	.018/.021 (0.5/0.5)
20	.029/.031 (0.7/0.8)
16	.038/.042 (1.0/1.1)

240-383E
MIL-DTL-38999 Series III Filter Connector
Dual Flange Jam Nut Receptacle



TABLE I: CONNECTOR CLASS

SYM	CLASS	MATERIAL	FINISH DESCRIPTION
M	Environmental	Aluminum	Electroless Nickel
MT	Environmental	Aluminum	Nickel Fluorocarbon Polymer (Ni-PTFE)
NF	Environmental	Aluminum	Cad. O.D. Over Electroless Nickel
P	Environmental	Stainless	Electro-Deposited Nickel
XM	Environmental	Composite	Electroless Nickel
XMT	Environmental	Composite	Nickel Fluorocarbon Polymer (Ni-PTFE)
XW	Environmental	Composite	Cad. O.D. Over Electroless Nickel
ZN	Environmental	Aluminum	Zinc-Nickel Over Electroless Nickel
H2*	Hermetic	Stainless	Electroless Nickel

* Some dimensions do not apply, see sales drawing 240-383JH2

**MIL-DTL-38999 Series III
Jam Nut Panel Cutout**

SHELL SIZE	Ø H	J
09	.710 (18.0)	.670 (17.0)
	.700 (17.8)	.660 (16.8)
11	.835 (21.2)	.771 (19.6)
	.825 (21.0)	.761 (19.3)
13	1.020 (25.9)	.955 (24.3)
	1.010 (25.7)	.945 (24.0)
15	1.145 (29.1)	1.085 (27.6)
	1.135 (28.8)	1.075 (27.3)
17	1.270 (32.3)	1.210 (30.7)
	1.260 (32.0)	1.200 (30.5)
19	1.395 (35.4)	1.335 (33.9)
	1.385 (35.2)	1.325 (33.7)
21	1.520 (38.6)	1.460 (37.1)
	1.510 (38.4)	1.450 (36.8)
23	1.645 (41.8)	1.585 (40.3)
	1.635 (41.5)	1.575 (40.0)
25	1.770 (45.0)	1.710 (43.4)
	1.760 (44.7)	1.700 (43.2)

**TABLE II: CAPACITOR ARRAY CODE
CAPACITANCE RANGE**

CLASS	PI - CIRCUIT (pF)	C - CIRCUIT (pF)
X*	160,000 - 240,000	80,000 - 120,000
Y*	80,000 - 120,000	40,000 - 60,000
Z*	60,000 - 90,000	30,000 - 45,000
A	38,000 - 56,000	19,000 - 28,000
B	32,000 - 45,000	16,000 - 22,500
C	18,000 - 33,000	9,000 - 16,500
D	8,000 - 12,000	4,000 - 6,000
E	3,300 - 5,000	1,650 - 2,500
F	800 - 1,300	400 - 650
G	400 - 600	200 - 300

* Reduced DWV – Please consult factory.

*Consult Factory for
Additional Filter Types,
TVS Diodes, and other
Custom Configurations.*

TABLE III: DIMENSIONS

SHELL SIZE	B Thread (Plated)	D ± .005	Ø E ± .012	F ± .016	P ± .010 (0.25)	R Thread Metric (Plated)	J Dia ± .005 (0.13)	K Dia Basic	L Dia ± .005 (0.13)	H ± .020 (0.51)	N ± .020 (0.51)
9	.625- .1P- .3L-TS-2A	.651 (16.5)	1.250 (31.8)	1.063 (27.0)	.225 (5.7)	M17 x 1-6g-0.10R	1.016 (25.8)	.752 (19.1)	.532 (13.5)	.225 (5.7)	.275 (7.0)
11	.7500- .1P- .3L-TS-2A	.751 (19.1)	1.377 (35.0)	1.259 (32.0)	.250 (6.4)	M20 x 1-6g-0.10R	1.062 (27.0)	.850 (21.6)	.595 (15.1)	.250 (6.4)	.290 (7.4)
13	.8750- .1P- .3L-TS-2A	.937 (23.8)	1.500 (38.1)	1.374 (34.9)	.250 (6.4)	M25 x 1-6g-0.10R	1.250 (31.8)	.994 (25.2)	.720 (18.3)	.375 (9.5)	.370 (9.4)
15	1.0000- .1P- .3L-TS-2A	1.063 (27.0)	1.625 (41.3)	1.500 (38.1)	.325 (8.2)	M28 x 1-6g-0.10R	1.375 (34.9)	1.119 (28.4)	.843 (21.4)	.438 (11.1)	.440 (11.2)
17	1.8750- .1P- .3L-TS-2A	1.187 (30.2)	1.750 (44.5)	1.625 (41.3)	.375 (9.5)	M32 x 1-6g-0.10R	1.500 (38.1)	1.237 (31.4)	1.000 (25.4)	.562 (14.3)	.495 (12.6)
19	1.2500- .1P- .3L-TS-2A	1.311 (33.3)	1.937 (49.2)	1.822 (46.3)	.500 (12.7)	M35 x 1-6g-0.10R	1.625 (41.3)	1.379 (35.0)	1.125 (28.6)	.875 (22.2)	.540 (13.7)
21	1.3750- .1P- .3L-TS-2A	1.434 (36.4)	2.063 (52.4)	1.940 (49.3)	.562 (14.3)	M38 x 1-6g-0.10R	1.750 (44.5)	1.489 (37.8)	1.240 (31.5)	1.170 (29.7)	.625 (15.9)
23	1.5000- .1P- .3L-TS-2A	1.561 (39.7)	2.190 (55.6)	2.073 (52.7)	.688 (17.5)	M41 x 1-6g-0.10R	1.875 (47.6)	1.619 (41.1)	1.328 (33.7)	1.250 (31.8)	.660 (16.8)
25	1.6250- .1P- .3L-TS-2A	1.687 (42.9)	2.311 (58.7)	2.189 (55.6)	.750 (19.1)	M44 x 1-6g-0.10R	2.000 (50.8)	1.744 (44.3)	1.453 (36.9)	1.375 (34.9)	.740 (18.8)

240-383R MIL-DTL-38999 Series III Filter Connector Wall Mount Receptacle with Crimp Removable Socket Contacts

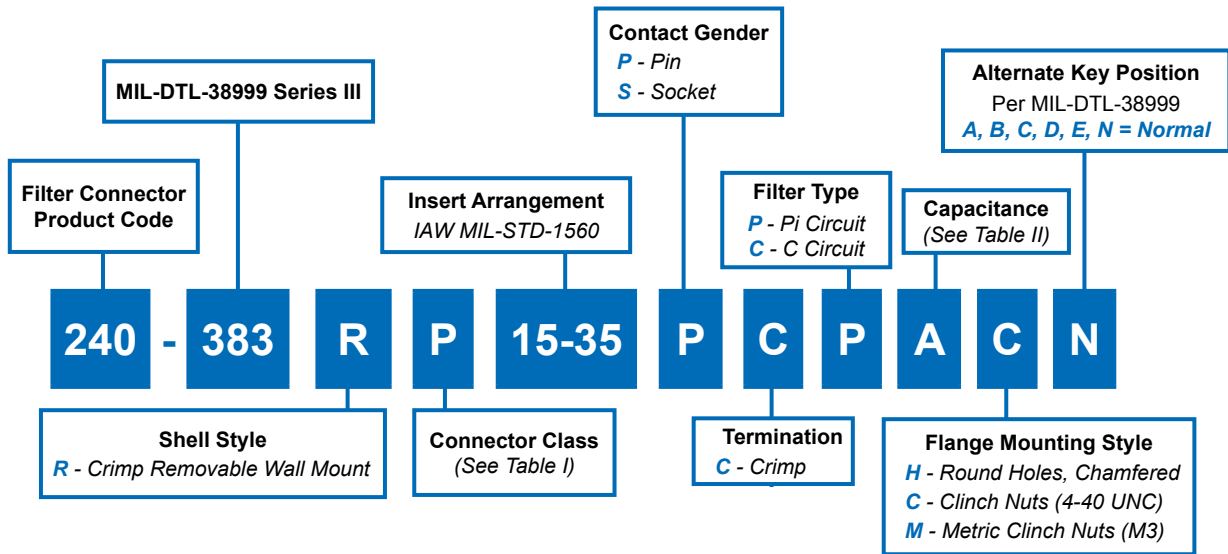

NOTE: Crimp removable socket contacts to conform to MIL-C-39029/57-358, Size 16, MIL-C-39029/57-357 Size 20, and MIL-C-39029/57-354 Size 22D (Supplied loose).

Clinch Nuts and Metric Clinch Nuts Not Available for Composites

R - Wall Mount with Crimp Removable Socket Contacts

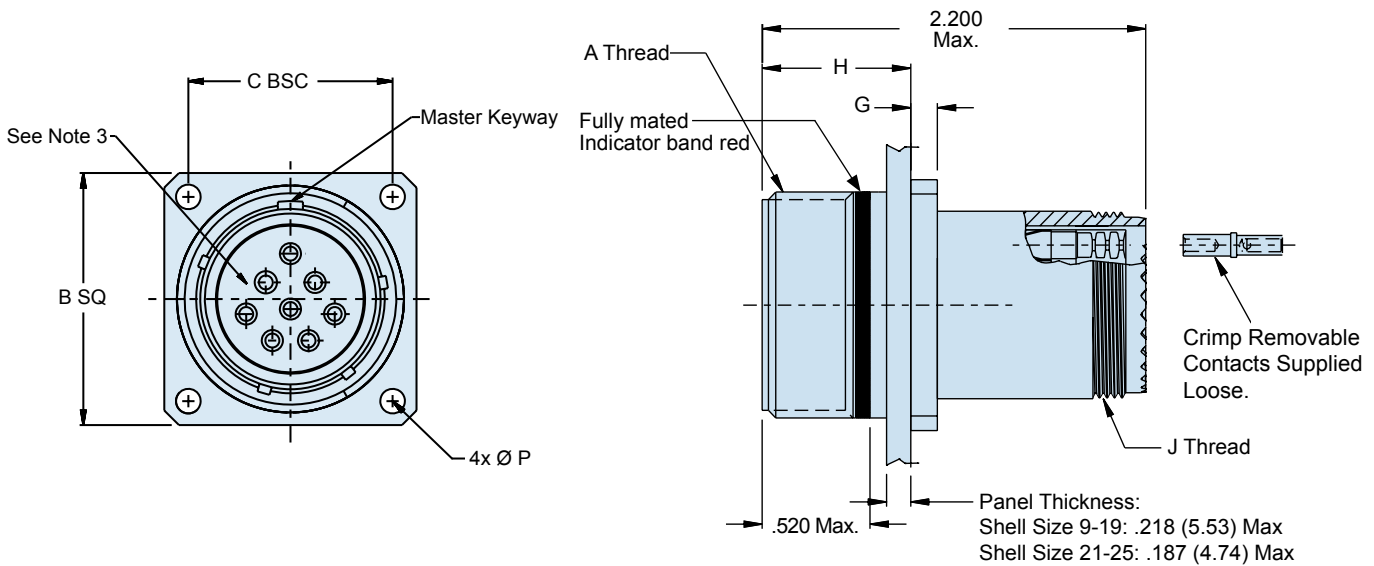

240-383R MIL-DTL-38999 Series III Filter Connector Wall Mount Receptacle with Crimp Removable Socket Contacts



EMI/EMP
Filters

Panel Cutout Dimensions			
Shell Size	ø L Min	M Holes	N BSC
09	.516 (13.1)	.133 (3.4) .123 (3.1)	.719 (18.3)
11	.625 (15.9)	.133 (3.4) .123 (3.1)	.812 (20.6)
13	.750 (19.1)	.133 (3.4) .123 (3.1)	.906 (23.0)
15	.906 (23.0)	.133 (3.4) .123 (3.1)	.969 (24.6)
17	1.016 (25.8)	.133 (3.4) .123 (3.1)	1.062 (27.0)
19	1.141 (29.0)	.133 (3.4) .123 (3.1)	1.156 (29.4)
21	1.266 (32.2)	.133 (3.4) .123 (3.1)	1.250 (31.8)
23	1.375 (34.9)	.159 (4.0) .149 (3.8)	1.375 (34.9)
25	1.484 (37.7)	.155 (3.9) .145 (3.7)	1.500 (38.1)

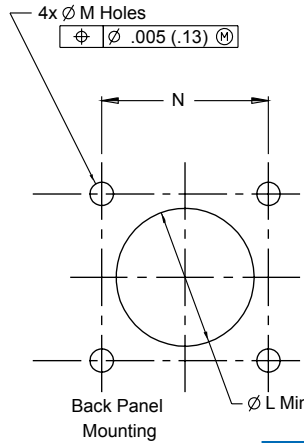

*Consult Factory for
Additional Filter Types,
TVS Diodes, and other
Custom Configurations.*

TABLE I: CONNECTOR CLASS			
SYM	CLASS	MATERIAL	FINISH DESCRIPTION
M	Environmental	Aluminum	Electroless Nickel
MT	Environmental	Aluminum	Nickel Fluorocarbon Polymer (Ni-PTFE)
NF	Environmental	Aluminum	Cad. O.D. Over Electroless Nickel
P	Environmental	Stainless	Electro-Deposited Nickel
XM	Environmental	Composite	Electroless Nickel
XMT	Environmental	Composite	Nickel Fluorocarbon Polymer (Ni-PTFE)
XW	Environmental	Composite	Cad. O.D. Over Electroless Nickel
ZN	Environmental	Aluminum	Zinc-Nickel Over Electroless Nickel
H2*	Hermetic	Stainless	Electroless Nickel

* Some dimensions do not apply, see sales drawing 240-383JH2

TABLE II: CAPACITOR ARRAY CODE CAPACITANCE RANGE		
CLASS	PI - CIRCUIT (pF)	C - CIRCUIT (pF)
X*	160,000 - 240,000	80,000 - 120,000
Y*	80,000 - 120,000	40,000 - 60,000
Z*	60,000 - 90,000	30,000 - 45,000
A	38,000 - 56,000	19,000 - 28,000
B	32,000 - 45,000	16,000 - 22,500
C	18,000 - 33,000	9,000 - 16,500
D	8,000 - 12,000	4,000 - 6,000
E	3,300 - 5,000	1,650 - 2,500
F	800 - 1,300	400 - 650
G	400 - 600	200 - 300

* Reduced DWV – Please consult factory.

WALL MOUNT WITH CRIMP CONTACTS											
SHELL SIZE CODE	SHELL SIZE	A THREAD	B SQ	C BSC	D BSC	E	F	G	H	J THREAD	PØ ± .010
A	09	.6250-.1P-.3L-TS-2A	0.949 (24.1) 0.925 (23.5)	.719 (18.3)	.594 (15.1)	.136 (3.5) .120 (3.0)	.224 (5.7) .208 (5.3)		.820 (20.8) .771 (19.6)	M12 X 1.0-6g 0.100R	
B	11	.7500-.1P-.3L-TS-2A	1.043 (26.5) 1.019 (25.9)	.812 (20.6)	.719 (18.3)	.136 (3.5) .120 (3.0)	.202 (5.1) .186 (4.7)		.820 (20.8) .771 (19.6)	M15 X 1.0-6g 0.100R	
C	13	.8750-.1P-.3L-TS-2A	1.138 (28.9) 1.114 (28.3)	.906 (23.0)	.812 (20.6)	.136 (3.5) .120 (3.0)	.202 (5.1) .186 (4.7)	.143 (3.6)	.820 (20.8) .771 (19.6)	M18 X 1.0-6g 0.100R	
D	15	1.000-.1P-.3L-TS-2A	1.232 (31.3) 1.208 (30.7)	.969 (24.6)	.906 (23.0)	.136 (3.5) .120 (3.0)	.202 (5.1) .186 (4.7)	.083 (2.1)	.820 (20.8) .771 (19.6)	M22 X 1.0-6g 0.100R	.128 (3.3)
E	17	1.1875-.1P-.3L-TS-2A	1.323 (33.6) 1.299 (33.0)	1.062 (27.0)	.969 (24.6)	.136 (3.5) .120 (3.0)	.202 (5.1) .186 (4.7)		.820 (20.8) .771 (19.6)	M25 X 1.0-6g 0.100R	
F	19	1.2500-.1P-.3L-TS-2A	1.449 (36.8) 1.425 (36.2)	1.156 (29.4)	1.062 (27.0)	.136 (3.5) .120 (3.0)	.202 (5.1) .186 (4.7)		.820 (20.8) .771 (19.6)	M28 X 1.0-6g 0.100R	
G	21	1.3750-.1P-.3L-TS-2A	1.575 (40.0) 1.551 (39.4)	1.250 (31.8)	1.156 (29.4)	.136 (3.5) .120 (3.0)	.202 (5.1) .186 (4.7)		.790 (20.1) .741 (18.8)	M31 X 1.0-6g 0.100R	
H	23	1.5000-.1P-.3L-TS-2A	1.701 (43.2) 1.677 (42.6)	1.375 (34.9)	1.250 (31.8)	.162 (4.1) .146 (3.7)	.250 (6.4) .083 (2.1)	.171 (4.3) .083 (2.1)	.790 (20.1) .741 (18.8)	M34 X 1.0-6g 0.100R	
J	25	1.6250-.1P-.3L-TS-2A	1.823 (46.3) 1.799 (45.7)	1.500 (38.1)	1.375 (34.9)	.162 (4.1) .146 (3.7)	.250 (6.4) .083 (2.1)		.790 (20.1) .741 (18.8)	M37 X 1.0-6g 0.100R	.156 (4.0)

© 2010 Glenair, Inc.

CAGE CODE 06324

Printed in U.S.A.

GLENAIR, INC. • 1211 AIR WAY • GLENDALE, CA 91201-2497 • 818-247-6000 • FAX 818-500-9912

www.glenair.com

C-35

E-Mail: sales@glenair.com

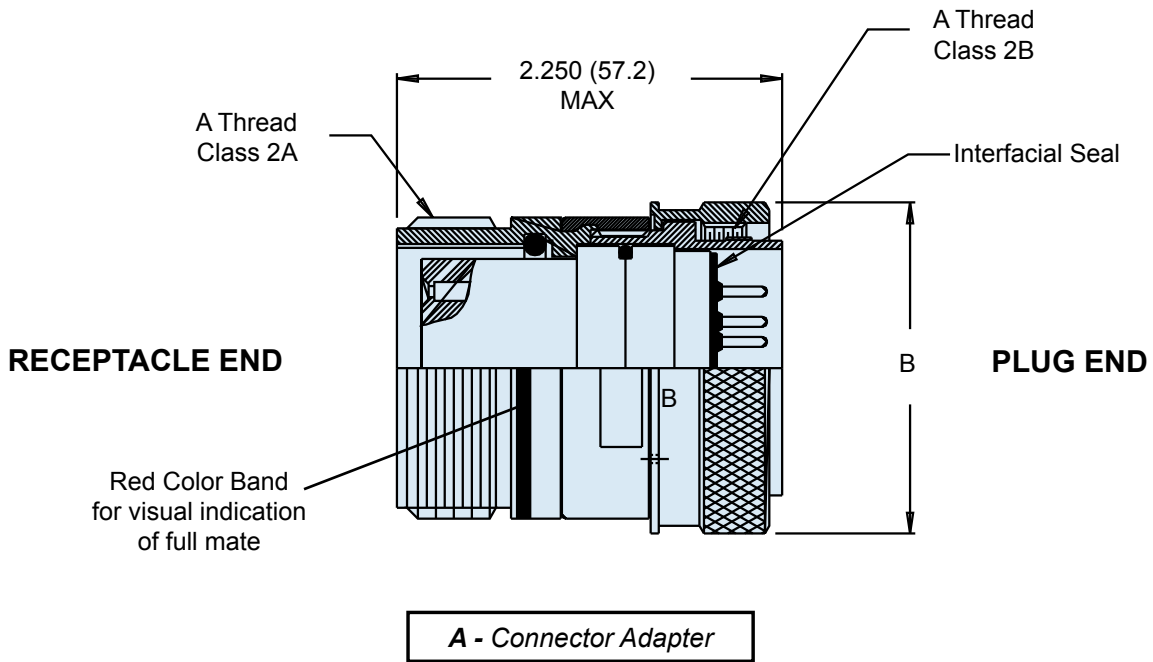
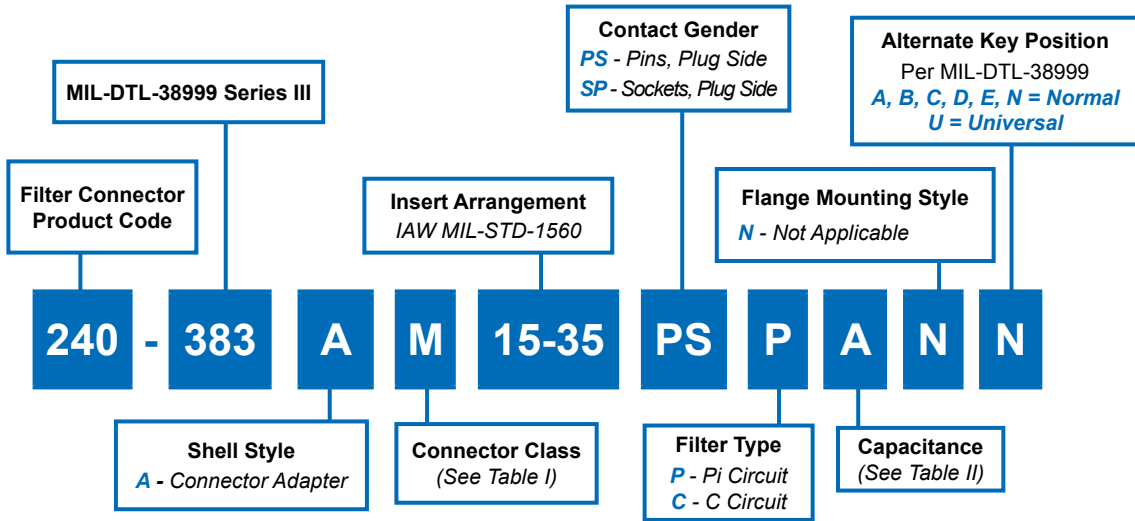

* Please consult factory for Pin/Pin and/or Socket/Socket contact arrangements.

240-383A MIL-DTL-38999 Series III Filter Connector Connector Adapter



TABLE I: CONNECTOR CLASS

SYM	CLASS	MATERIAL	FINISH DESCRIPTION
M	Environmental	Aluminum	Electroless Nickel
MT	Environmental	Aluminum	Nickel Fluorocarbon Polymer (Ni-PTFE)
NF	Environmental	Aluminum	Cad. O.D. Over Electroless Nickel
P	Environmental	Stainless	Electro-Deposited Nickel
ZN	Environmental	Aluminum	Zinc-Nickel Over Electroless Nickel
H2*	Hermetic	Stainless	Electroless Nickel

*Consult Factory for
Additional Filter Types,
TVS Diodes, and other
Custom Configurations.*

* Some dimensions do not apply, see sales drawing 240-383JH2

**TABLE II: CAPACITOR ARRAY CODE
CAPACITANCE RANGE**

CLASS	PI - CIRCUIT (pF)	C - CIRCUIT (pF)
X*	160,000 - 240,000	80,000 - 120,000
Y*	80,000 - 120,000	40,000 - 60,000
Z*	60,000 - 90,000	30,000 - 45,000
A	38,000 - 56,000	19,000 - 28,000
B	32,000 - 45,000	16,000 - 22,500
C	18,000 - 33,000	9,000 - 16,500
D	8,000 - 12,000	4,000 - 6,000
E	3,300 - 5,000	1,650 - 2,500
F	800 - 1,300	400 - 650
G	400 - 600	200 - 300

* Reduced DWV – Please consult factory.

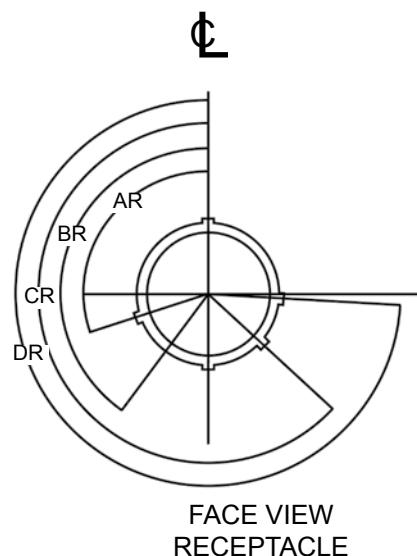

DIMENSIONS

SHELL SIZE CODE	SHELL SIZE	A THREAD CLASS 2	B DIA. MAX
A-1	09	.6250- .1P- .3L-TS-2A	.858 (21.8)
B-1	11	.7500- .1P- .3L-TS-2A	.984 (25.0)
C-1	13	.8750- .1P- .3L-TS-2A	1.157 (29.4)
D-1	15	1.000- .1P- .3L-TS-2A	1.280 (32.5)
E-1	17	1.1875- .1P- .3L-TS-2A	1.406 (35.7)
F-1	19	1.2500- .1P- .3L-TS-2A	1.516 (38.5)
G-1	21	1.3750- .1P- .3L-TS-2A	1.642 (41.7)
H-1	23	1.5000- .1P- .3L-TS-2A	1.768 (44.9)
J-1	25	1.6250- .1P- .3L-TS-2A	1.890 (48.0)



**Glenair MIL-DTL-38999 Series IV Type
Filter Connector with Breech-Lock Coupling
Master How to Order • Part Number Breakdown**

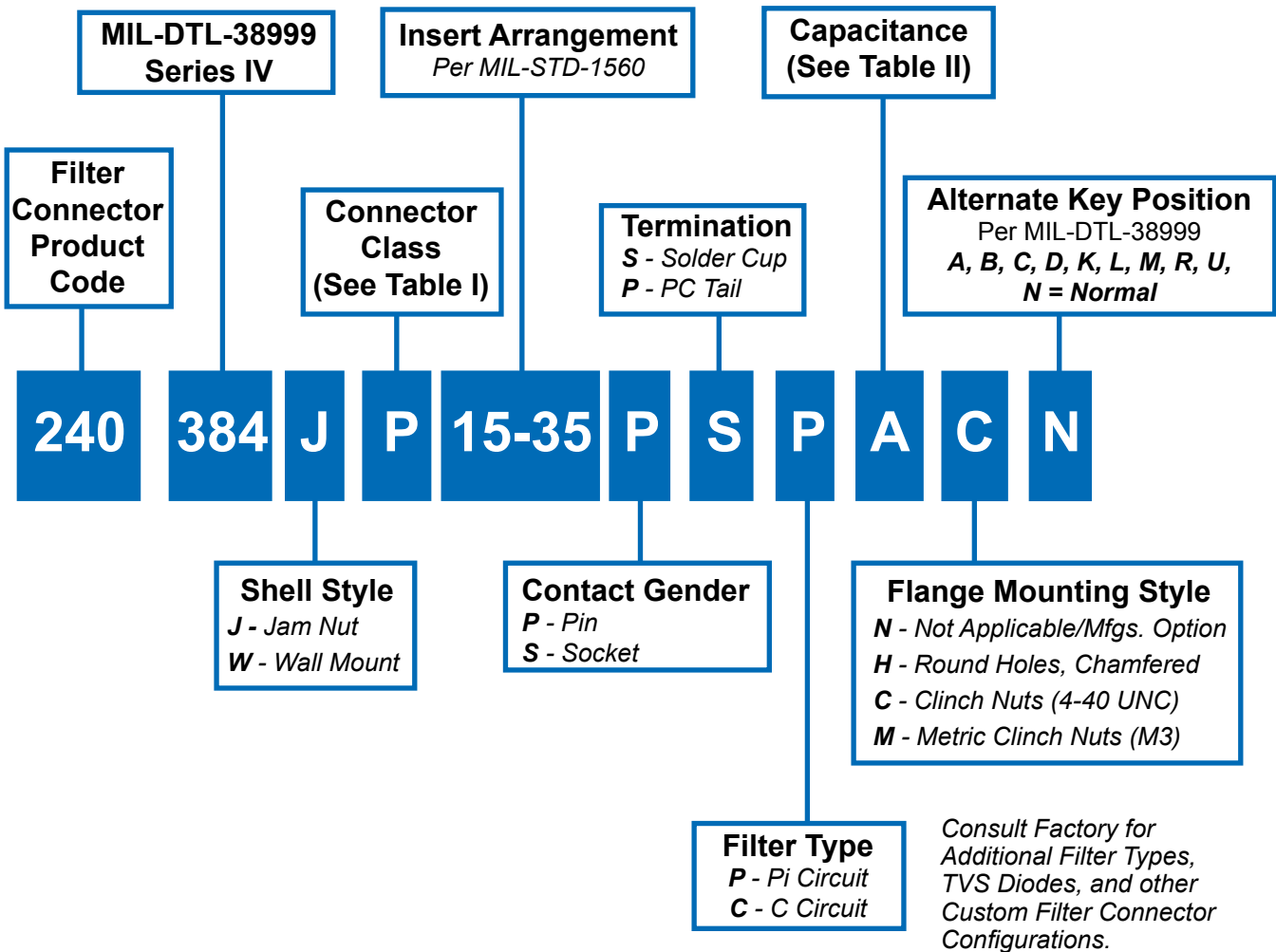

TABLE I: CONNECTOR CLASS

SYM	CLASS	MATERIAL	FINISH DESCRIPTION
M	Environmental	Aluminum	Electroless Nickel
MT	Environmental	Aluminum	Nickel Fluorocarbon Polymer (Ni-PTFE)
NF	Environmental	Aluminum	Cadmium O.D. Over Electroless Nickel
P	Environmental	Stainless Steel	Electro-Deposited Nickel
ZN	Environmental	Aluminum	Zinc-Nickel Over Electroless Nickel
H2	Hermetic	Stainless Steel	Electroless Nickel

**Glenair MIL-DTL-38999 Series IV Type
Filter Connector with Breech-Lock Coupling
Reference Information**



**TABLE II: CAPACITOR ARRAY CODE
CAPACITANCE RANGE**

CLASS	PI - CIRCUIT (pF)	C - CIRCUIT (pF)
X*	160,000 - 240,000	80,000 - 120,000
Y*	80,000 - 120,000	40,000 - 60,000
Z*	60,000 - 90,000	30,000 - 45,000
A	38,000 - 56,000	19,000 - 28,000
B	32,000 - 45,000	16,000 - 22,500
C	18,000 - 33,000	9,000 - 16,500
D	8,000 - 12,000	4,000 - 6,000
E	3,300 - 5,000	1,650 - 2,500
F	800 - 1,300	400 - 650
G	400 - 600	200 - 300

* Reduced DWV – Please consult factory.

APPLICATION NOTES

- Materials/Finishes: Shells, Barrel, Coupling Nut, Jam Nut - See Table I
Insulators - high grade rigid dielectric/N.A.
Seals - Fluorosilicone
PC Tail & Solder Cup contacts: 50µ" Gold over 50µ" Nickel
- Assembly to be identified with Glenair's name, part number, and date code - space permitting.
- Insert Arrangement in accordance with MIL-STD-1560.
(Arrangement shown for reference only)
- EMI Circular Filter Receptacle connector designed to meet requirements of MIL-STD-2120 and MIL-DTL-38999, Series IV.
- All contacts to have identical filter value. Other filter arrangements available, contact factory.
- Electrical Ratings: DWV- 500 VDC; Standard Operating Voltage 200 Volts DC; Current Rating 5 Amps (size 22);
- Insulation Resistance: 5000 MegOhms Min. at 200 VDC.
- Operating Temperature -55°C to +125°C (Env Class Connectors)
- Other filter styles (C-L, L-C, Unbalanced PI, Multi-Stage, Multi-Value) are available, please consult the factory.
- Metric Dimensions (mm) are indicated in parentheses.

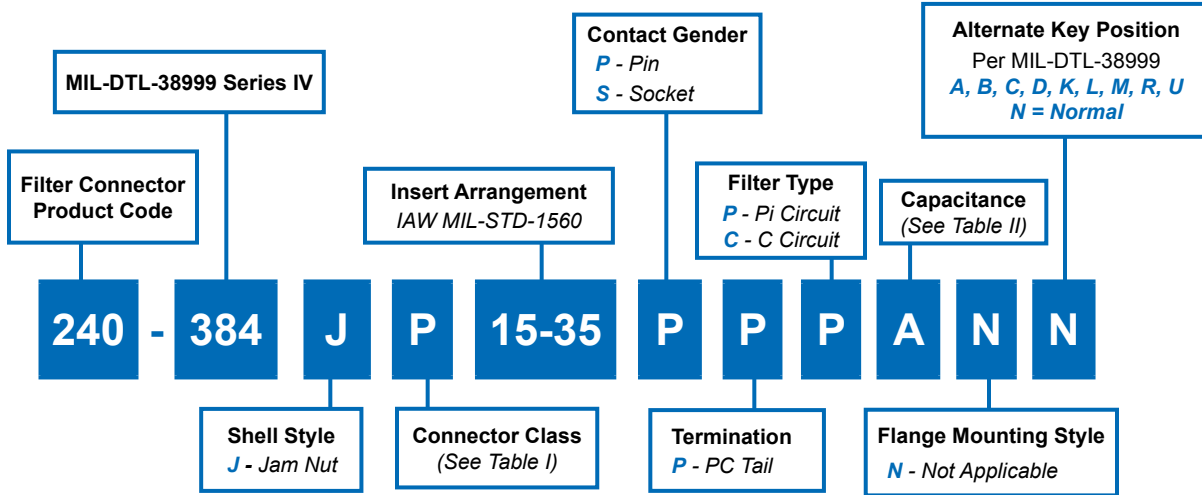

C

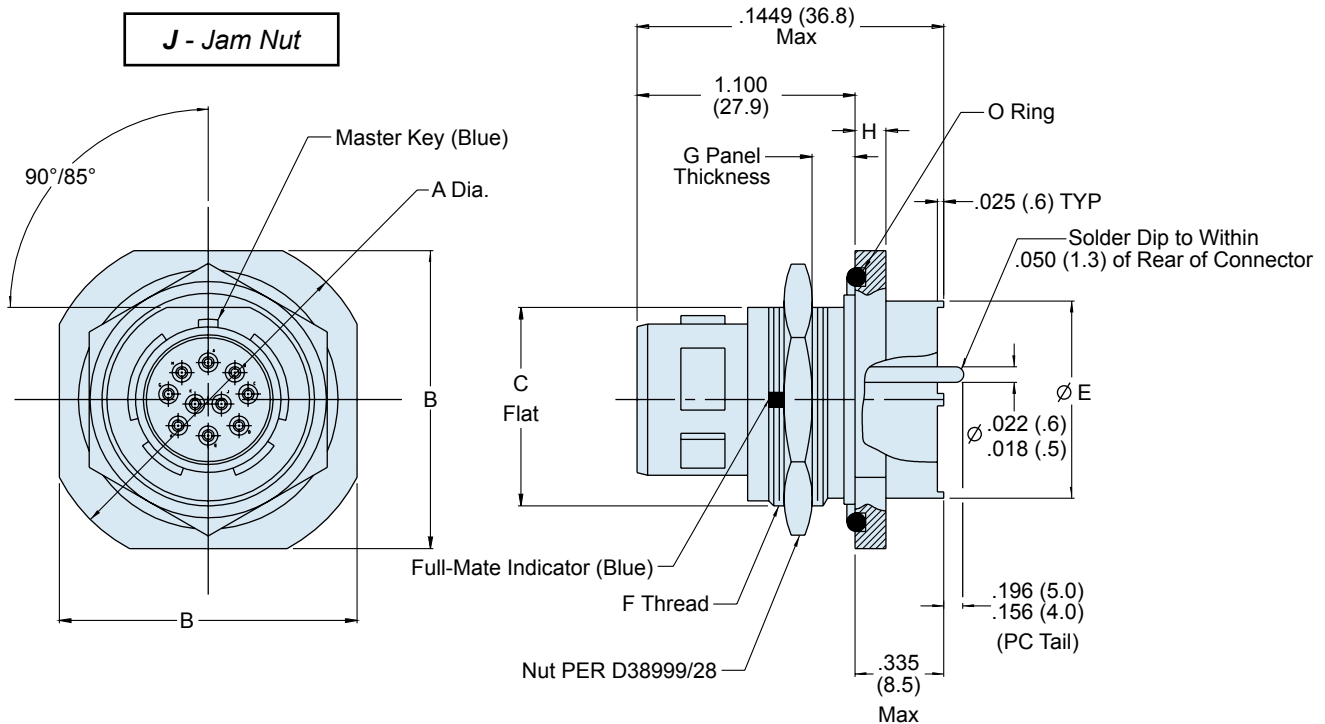

240-384J
MIL-DTL-38999 Series IV Filter Connector
Jam Nut Receptacle

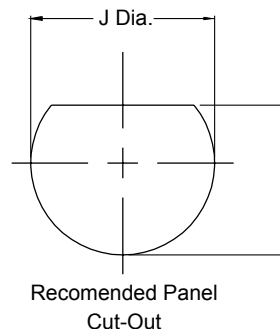

TABLE I: CONNECTOR CLASS

SYM	CLASS	MATERIAL	FINISH DESCRIPTION
M	Environmental	Aluminum	Electroless Nickel
MT	Environmental	Aluminum	Nickel Fluorocarbon Polymer (Ni-PTFE)
NF	Environmental	Aluminum	Cadmium O.D. Over Electroless Nickel
P	Environmental	Stainless Steel	Electro-Deposited Nickel
ZN	Environmental	Aluminum	Zinc-Nickel Over Electroless Nickel
H2	Hermetic	Stainless Steel	Electroless Nickel

TABLE II: CAPACITOR ARRAY CODE
CAPACITANCE RANGE

CLASS	PI - CIRCUIT (pF)	C - CIRCUIT (pF)
X*	160,000 - 240,000	80,000 - 120,000
Y*	80,000 - 120,000	40,000 - 60,000
Z*	60,000 - 90,000	30,000 - 45,000
A	38,000 - 56,000	19,000 - 28,000
B	32,000 - 45,000	16,000 - 22,500
C	18,000 - 33,000	9,000 - 16,500
D	8,000 - 12,000	4,000 - 6,000
E	3,300 - 5,000	1,650 - 2,500
F	800 - 1,300	400 - 650
G	400 - 600	200 - 300



* Reduced DWV – Please consult factory.

TABLE III: DIMENSIONS

SHELL SIZE CODE	SHELL SIZE	A Diameter	B	C FLAT	E DIAMETER	F THREAD ISO METRIC	G	H	J Diameter	K
B	11	1.385 (35.2)	1.267 (32.2)	.754 (19.2)	.779 (19.8)	M20 X 1.0-6g	.125 (3.2)	.118 (3.0)	.832 (21.1)	.769 (19.5)
		1.362 (34.6)	1.232 (31.3)	.745 (18.9)	.759 (19.3)		.059 (1.5)	.094 (2.4)	.822 (20.9)	.759 (19.3)
C	13	1.511 (38.4)	1.393 (35.4)	.941 (23.9)	.909 (23.1)	M25 X 1.0-6g	.125 (3.2)	.118 (3.0)	1.017 (25.8)	.955 (24.3)
		1.488 (37.8)	1.358 (34.5)	.932 (23.7)	.889 (22.6)		.059 (1.5)	.094 (2.4)	1.007 (25.6)	.945 (24.0)
D	15	1.637 (41.6)	1.519 (38.6)	1.065 (27.1)	1.035 (26.3)	M28 X 1.0-6g	.125 (3.2)	.118 (3.0)	1.144 (29.1)	1.084 (27.5)
		1.614 (41.0)	1.484 (37.7)	1.056 (26.8)	1.015 (25.8)		.059 (1.5)	.094 (2.4)	1.134 (28.8)	1.074 (27.3)
E	17	1.763 (44.8)	1.641 (41.7)	1.190 (30.2)	1.157 (29.4)	M32 X 1.0-6g	.125 (3.2)	.118 (3.0)	1.271 (32.3)	1.208 (30.7)
		1.740 (44.2)	1.606 (40.8)	1.181 (30.0)	1.137 (28.9)		.059 (1.5)	.094 (2.4)	1.261 (32.0)	1.198 (30.4)
F	19	1.948 (49.5)	1.830 (46.5)	1.316 (33.4)	1.283 (32.6)	M35 X 1.0-6g	.125 (3.2)	.149 (3.8)	1.394 (35.4)	1.333 (33.9)
		1.925 (48.9)	1.795 (45.6)	1.306 (33.2)	1.263 (32.1)		.059 (1.5)	.125 (3.2)	1.384 (35.2)	1.323 (33.6)
G	21	2.074 (52.7)	1.956 (49.7)	1.441 (36.6)	1.409 (35.8)	M38 X 1.0-6g	.125 (3.2)	.149 (3.8)	1.517 (38.5)	1.459 (37.1)
		2.051 (52.1)	1.921 (48.8)	1.431 (36.3)	1.389 (35.3)		.059 (1.5)	.125 (3.2)	1.507 (38.3)	1.449 (36.8)
H	23	2.200 (55.9)	2.078 (52.8)	1.565 (39.8)	1.535 (39.0)	M41 X 1.0-6g	.125 (3.2)	.149 (3.8)	1.644 (41.8)	1.580 (40.1)
		2.177 (55.3)	2.043 (51.9)	1.556 (39.5)	1.515 (38.5)		.059 (1.5)	.125 (3.2)	1.634 (41.5)	1.570 (39.9)
J	25	2.326 (59.1)	2.204 (56.0)	1.692 (43.0)	1.657 (42.1)	M44 X 1.0-6g	.125 (3.2)	.149 (3.8)	1.769 (44.9)	1.709 (43.4)
		2.299 (58.4)	2.169 (55.1)	1.681 (42.7)	1.637 (41.6)		.059 (1.5)	.125 (3.2)	1.759 (44.7)	1.699 (43.2)

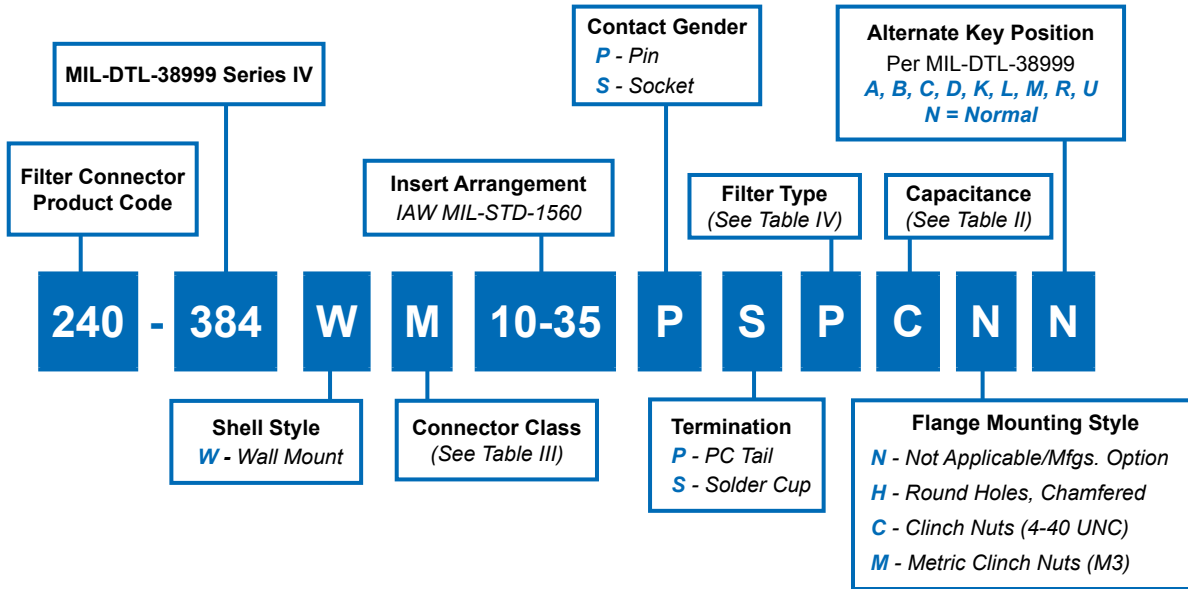

W - Wall Mount

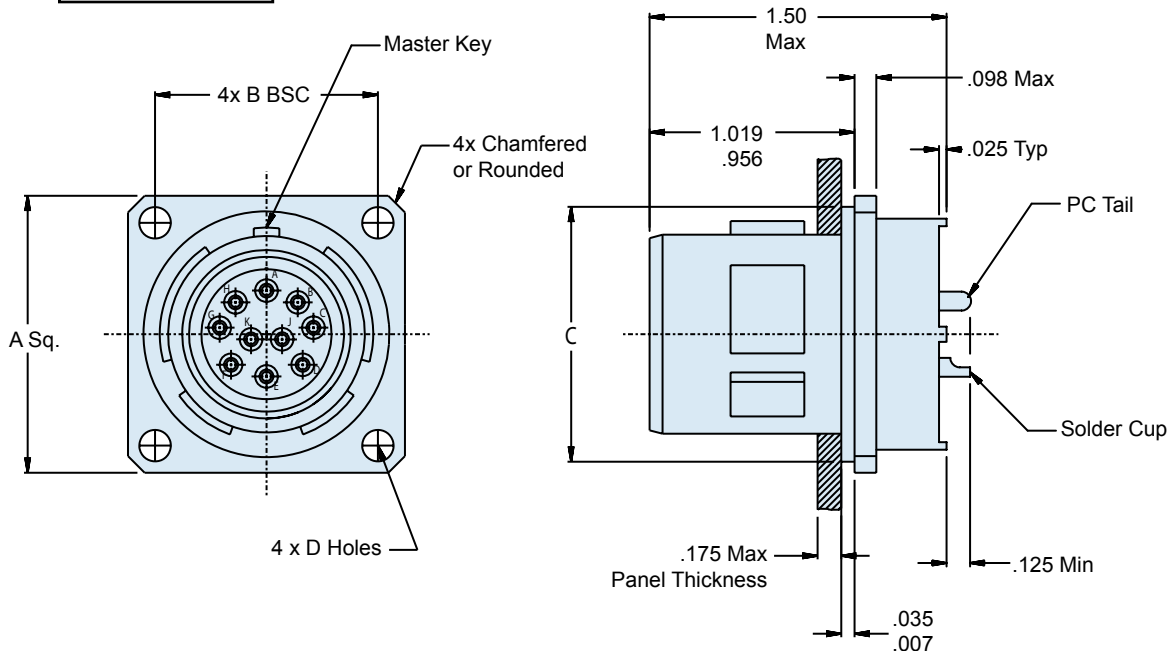

240-384W MIL-DTL-38999 Series IV Filter Connector Wall Mount Receptacle



EMI/EMP
Filters

TABLE I: CONNECTOR CLASS

SYM	CLASS	MATERIAL	FINISH DESCRIPTION
M	Environmental	Aluminum	Electroless Nickel
MT	Environmental	Aluminum	Nickel Fluorocarbon Polymer (Ni-PTFE)
NF	Environmental	Aluminum	Cadmium O.D. Over Electroless Nickel
P	Environmental	Stainless Steel	Electro-Deposited Nickel
ZN	Environmental	Aluminum	Zinc-Nickel Over Electroless Nickel
H2	Hermetic	Stainless Steel	Electroless Nickel

TABLE IV

SYM	Filter Type
P	PI Circuit
C	C Circuit

**TABLE II: CAPACITOR ARRAY CODE
CAPACITANCE RANGE**

CLASS	PI - CIRCUIT (pF)	C - CIRCUIT (pF)
X*	160,000 - 240,000	80,000 - 120,000
Y*	80,000 - 120,000	40,000 - 60,000
Z*	60,000 - 90,000	30,000 - 45,000
A	38,000 - 56,000	19,000 - 28,000
B	32,000 - 45,000	16,000 - 22,500
C	18,000 - 33,000	9,000 - 16,500
D	8,000 - 12,000	4,000 - 6,000
E	3,300 - 5,000	1,650 - 2,500
F	800 - 1,300	400 - 650
G	400 - 600	200 - 300

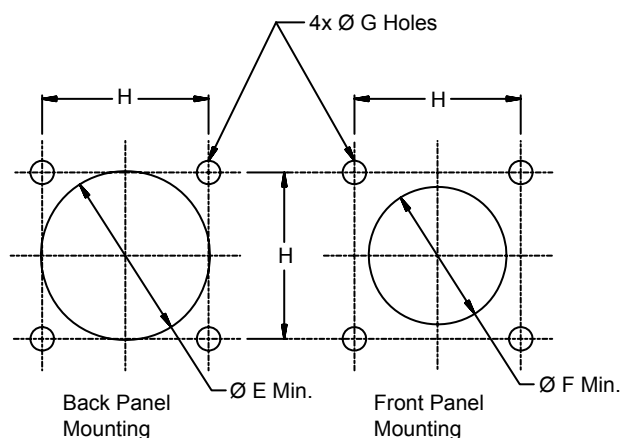

* Reduced DWV – Please consult factory.

TABLE III

SHELL SIZE CODE	SHELL SIZE	A Sq	B BSC	C Diameter	D Diameter	Ø E Min.	Ø F Min.	Ø G Holes	H
B	11	1.051	.812	.793	.138	.781	.625	.133	.817
		1.008		.778	.122			.123	.807
C	13	1.145	.906	.919	.138	.921	.750	.133	.911
		1.102		.904	.122			.123	.901
D	15	1.240	.969	1.044	.138	1.047	.906	.133	.973
		1.197		1.029	.122			.123	.963
E	17	1.334	1.062	1.170	.138	1.218	1.016	.133	1.067
		1.291		1.155	.122			.123	1.057
F	19	1.460	1.156	1.294	.138	1.296	1.142	.133	1.161
		1.417		1.279	.122			.123	1.151
G	21	1.583	1.250	1.419	.138	1.421	1.266	.133	1.255
		1.539		1.404	.122			.123	1.245
H	23	1.709	1.375	1.544	.157	1.546	1.375	.159	1.380
		1.665		1.529	.142			.149	1.370
J	25	1.835	1.500	1.670	.157	1.672	1.484	.159	1.505
		1.791		1.654	.142			.149	1.495

Glenair MIL-DTL-38999 Environmental Class Connectors

SECTION D TABLE OF CONTENTS

GLENAIR ENVIRONMENTAL CLASS CLASS CONNECTORS:

MIL-DTL-38999 Type Environmental Class Connector Product Features.....	D-1
Insert Arrangements IAW MIL-STD-1560.....	D-2
MIL-DTL-38999 Material Specifications.....	D-5
MIL-DTL-38999 Crimp Tools and Accessories.....	D-6
MIL-DTL-38999 Pin Contact Selection Guide.....	D-8
MIL-DTL-38999 Socket Contact Selection Guide.....	D-9
MIL-DTL-38999 Series III Type Wall Mount Environmental Class Receptacle.....	D-11
MIL-DTL-38999 Series III Type Jam Nut Environmental Class Receptacle.....	D-14
MIL-DTL-38999 Series III Type In-Line Environmental Class Receptacle.....	D-16
MIL-DTL-38999 Series III Type Environmental Class Plug.....	D-18
MIL-DTL-38999 Series III Type Box Mount Quadrax Connector.....	D-20
MIL-DTL-38999 Series III Type Plug and Wall Mount Quadrax Connector.....	D-22
MIL-DTL-38999 Series III Type Quadrax Socket Contact.....	D-24
MIL-DTL-38999 Series I Type Shorting Plug.....	D-25
MIL-DTL-38999 Series I Type Jam Nut Shorting Receptacle.....	D-26
MIL-DTL-38999 Series I Type Shorting Bulkhead Feed-Thru Bulkhead.....	D-28
MIL-DTL-38999 Series II Type Shorting Plug.....	D-29
MIL-DTL-38999 Series III Type Quick Disconnect Plug with Swivel Lanyard.....	D-30
MIL-DTL-38999 Type 4 Lanyard Release Plug for MIL-STD-1760.....	D-32

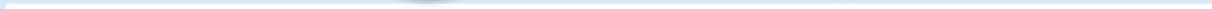

Environmental Class MIL-DTL-38999 Type Connectors Built for a Broad Range of Harsh-Environment Applications

Product Applications

Glenair is recognized as trusted supplier of harsh environment electrical connectors built to the MIL-DTL-38999 standard. This section of the catalog presents a selection of the environmental class MIL-DTL-38999 type solutions produced by Glenair. Glenair's expertise in these harsh-environmental interconnect products extends to lanyard release quick-disconnect products, shorting plugs and receptacles, composite and specialty metal plugs and receptacles as well as unique coax and quadrax configurations. We can also supply the interconnects in turnkey harsh application cable sets.

Available Insert Arrangements

Based on industry-standard specifications, Glenair's MIL-DTL-38999 derivative environmental class connector systems are supplied with insert arrangements IAW MIL-STD-1560, or appropriate sub-sets depending on connector series. Consult factory for available insert arrangements.

Errata

Catalog contents—including part numbers, materials and dimensions—are accurate to the best of our ability when we go to print. When errors or mistakes are brought to our attention, corrected content is posted immediately to www.glenair.com.

Same-Day Delivery on Many Common Shell Styles and Layouts

*Selected Range of D38999 Series I thru III Pin and Socket
Insert Arrangements—Consult Factory for Availability*

Lightweight, Corrosion-Free Composite Versions

Special Lanyard-Release Versions

All Standard Material Options, Including Stainless Steel

Jam Nut, Solder Mount, Wall Mount and Box Mount Options

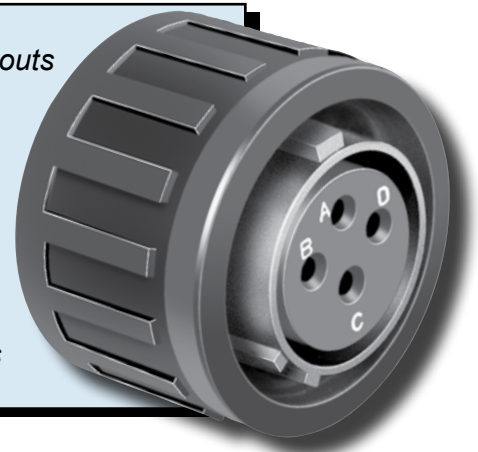

D



MIL-DTL-38999 Series I, II and III Type Environmental Class Connectors Insert Arrangements (IAW MIL-STD-1560)

Series I	9-35	9-98	11-2	11-4	11-5	11-35	11-98	11-99
Series II	8-35	8-98	10-2	10-4	10-5	10-35	10-98	10-99
Series III	A35	A98	B2	B4	B5	B35	B98	B99
Series IV	---	---	---	---	B5	B35	B98	B99

Series I	13-4	13-8	13-35	13-98
Series II	12-4	12-8	12-35	12-98
Series III	C4	C8	C35	C98
Series IV	C4	---	C35	C98

Series I	15-5	15-15	15-18	15-19	15-35	15-97
Series II	14-5	14-15	14-18	14-19	14-35	14-97
Series III	D5	D15	D18	D19	D35	D97
Series IV	D5	---	D18	D19	D35	D97

D

Series I	17-6	17-8	17-26	17-35	17-99
Series II	16-6	16-8	16-26	16-35	16-99
Series III	E6	E8	E26	E35	E99
Series IV	E6	E8	E26	E35	---

Series I	19-11	19-28	19-32	19-35	19-30	19-45
Series II	18-11	18-28	18-32	18-35	18-30	18-45
Series III	F11	F28	F32	F35	F30	F45
Series IV	F11	---	F32	F35	---	---

Consult factory for available insert arrangements.



MIL-DTL-38999 Series I, II and III Type Environmental Class Connectors Insert Arrangements (IAW MIL-STD-1560)



Series I 21-11	21-16	21-35	21-41	
Series II 20-11	20-16	20-35	20-41	
Series III, IV G11, G11	G16, G16	G35, G35	G41, G41	
Series I 21-24	21-25	21-27	21-39	
Series II 20-24	20-25	20-27	20-39	
Series III, IV G24, G24	G25, ---	G27, ---	G39, ---	
Series I 23-21	23-35	23-53	23-55	23-32
Series II 22-21	22-35	22-53	22-55	22-32
Series III, IV H21, H21	H35, H35	H53, ---	H55, H55	H32, ---
Series I 23-34	23-36	23-97	23-99	
Series II 22-34	22-36	22-97	22-99	
Series III, IV H34, ---	H36, ---	H97, ---	H99, ---	
Series I 25-29	25-35	25-61	25-4	
Series II 24-29	24-35	24-61	24-4	
Series III, IV J29, J29	J35, J35	J61, J61	J4, J4	
Series I 25-43	25-19	25-24	J-11	
Series II 24-43	24-19	24-24	(Series IV Only)	
Series III, IV J43, J43	J19, J19	J24, J24		

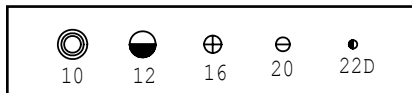



MIL-DTL-38999 Series I, II and III Type Environmental Class Connectors Insert Arrangements (IAW MIL-STD-1560)

Shell Size and Insert Arrangements			Number of Pins			
MS Series I	MS Series II	D38999 Series III	22D	20	16	12
9-35	8-35	A35	6			
9-98	8-98	A98		3		
11-2	10-2	B2			2	
11-4	10-4	B4		4		
11-5	10-5	B5		5		
11-35	10-35	B35	13			
11-98	10-98	B98		6		
11-99	10-99	B99		7		
13-4	12-4	C4			4	
13-8	12-8	C8		8		
13-35	12-35	C35	22			
13-98	12-98	C98		10		
15-5	14-5	D5			5	
15-15	14-15	D15		14	1	
15-18	14-18	D18		18		
15-19	14-19	D19		19		
15-35	14-35	D35	37			
15-97	14-97	D97		8	4	
17-6	16-6	E6				6
17-8	16-8	E8			8	
17-26	16-26	E26		26		
17-35	16-35	E35	55			
17-99	16-99	E99		21	2	
19-11	18-11	F11			11	
19-28	18-28	F28		26	2	
19-30	18-30	F30		29	1	
19-32	18-32	F32		32		
19-35	18-35	F35	66			
19-45	18-45	F45	67			
21-11	20-11	G11				11
21-16	20-16	G16			16	
21-24	20-24	G24		24		
21-25	20-25	G25		25		
21-27	20-27	G27		27		
21-35	20-35	G35	79			
21-39	20-39	G39		37	2	
21-41	20-41	G41		41		
23-21	22-21	H21			21	
23-32	22-32	H32		32		
23-34	22-34	H34		34		
23-35	22-35	H35	100			
23-36	22-36	H36		36		
23-53	22-53	H53		53		
23-55	22-55	H55		55		
23-97	22-97	H97			16	
23-99	22-99	H99			11	
25-4	24-4	J4		48	8	
25-19	24-19	J19				19
25-24	24-24	J24			12	12
25-29	24-29	J29			29	
25-35	24-35	J35	128			
25-43	24-43	J43		23	20	
25-61	24-61	J61		61		

Shell Size / Insert Arrangements		Number of Pins				
D38999 Series IV	22D	20	16	12	10	
B5		5				
B35	13					
B98		6				
B99		7				
C4			4			
C35	22					
C98		10				
D5			5			
D18		18				
D19	37	19				
D35						
D97		8	4			
E6				6		
E8			8			
E26		26				
E35	55					
F11			11			
F32		32				
F35	66					
G11				11		
G16			16			
G35	79					
G41		41				
H21			21			
H35	100					
H55		55				
J4		48	8			
J11		2			9	
J19				19		
J24			12	12		
J29			29			
J35	128					
J43		23	20			
J61		61				

MIL-DTL-38999 Series I, II and III Environmental Class Connectors Material Specifications



TABLE I: MATERIALS

Shell, Barrel, and Coupling Nut	Aluminum alloy 6061 per ASTM-B211
Front and Rear Insulators	Glass-filled LCP in accordance with MIL-M-24519, Type GLP-30F
Contact Retention Clip	Beryllium copper, heat-treated, unplated
Grommet, Peripheral Seal and Interfacial Seal	Blended elastomer, 30% silicone per ZZ-R-765, 70% fluorosilicone per MIL-R-25988
Pin / Socket Contacts (Environmental)	Copper Alloy / Gold Plate
Socket Contact (Hermetic)	Copper Alloy, Gold Plated IAW ASTM B488, Type 3, Code C
Adhesives	Silicone and epoxy
Potting Compound: PCB and Solder Cup	High-strength epoxy, Hysol EE4215.

TABLE II: POPULAR ENVIRONMENTAL CLASS CONNECTOR FINISHES

Plating Code	Material	Finish	Specification
M	Aluminum	Electroless Nickel	AMS-C-26074
B	Aluminum	Cad Plate, Olive Drab	AMS-QQ-P-416, Type II, Class 3
NF	Aluminum	Cadmium Plate Olive Drab over Electroless Nickel	AMS-QQ-P-416, over AMS-C-26074 (1000 Hour Salt Spray)
ZN	Aluminum	Olive Drab Zinc-Nickel	Zinc alloy per ASTM B841-91, Class 1 Type E Grade 3 over Electroless nickel per ASTM B733-90 SC2, Type 1 Class 5
MT	Aluminum	Ni-PTFE 1,000 Hour Grey™ (Nickel Fluorocarbon Polymer)	MIL-DTL-38999L (500 Hour Salt Spray)
XM	Composite	Electroless Nickel	AMS-C-26074
XMT	Composite	Ni-PTFE 1,000 Hour Grey™ (Nickel Fluorocarbon Polymer)	MIL-DTL-38999L (2000 Hour Salt Spray)
XW	Composite	Cadmium Olive Drab over Electroless Nickel	AMS-QQ-P-416, over AMS-C-26074 (1000 Hour Salt Spray)
Z1	Stainless Steel	Passivate	AMS-QQ-P-35
ZL	Stainless Steel	Electrodeposited Nickel	SAE-AMS-QQ-N-290, Class 2



#8 Quadrax Contacts for Glenair Series 257-455 and 257-459 Connectors

Contact Size	Type	Glenair Part Number	Military Part Number	Tool Code	Cable Type Dash No.	Wire Size	Sample Contact
#8	Quadrax	854-001	N/A	C, J (Inner) K, M (Outer)	01 - Tensolite NF26Q100	26AWG	
		854-002			02 - Tensolite NF24Q100	24AWG	
				03 - Draka Fileca F 4704-6	26AWG		
				04 - Draka Fileca F 4704-4	24AWG		

Consult factory for PC tail/other cable options

Crimp Tool And Positioner For #12 and #16 Power Contacts



1 Crimp tool for use with size #16 and #12 power pins. 9.75 inches OAL, 1.25 pounds. Use with M39029/57 and /58 contacts and 809-093 adapters.

2 Positioner for use with size #12 and #16 Power contacts.

Figure	Military Part Number	Daniels Part Number	Tool Code
1	M22520/1-01	AF8	A
2	M22520/1-04	TH163	B

Miniature Adjustable Crimp Tool



These crimp tools perform precision eight indent crimps for gas-tight wire terminations and excellent tensile strength. Adjustment wheel has 8 settings. Ratchet mechanism prevents improper crimps. Use with bayonet-type positioners. Check calibration with M22520/3 gages. Length is 6.75 inches, weight is approx. 10 oz.

1 Standard M22520/2-01 miniature crimper. Use with standard size #20 and #22D contacts and with M39029/76, /77 and /78 coaxial center contacts. Requires positioner, ordered separately.

Glenair Part Number	Military Part Number	Daniels Part Number	Tool Code
809-015	M22520/2-01	AFM8	C

2 Positioner for M39029/76, 77 and 78 coaxial inner contact. Use with 809-015 crimp tool.



Coax/Power	Contact Size	Military Part Number	Daniels Part Number	Notes	Tool Code
Power	#20	M22520/2-10	K43	Series I, II, III and IV	D
Power	#22D	M22520/2-09	K42	Series I, II, III and IV Pin	E
Power	#22D	M22520/2-07	K40	Series I, III and IV Socket	F
Power	#22D	M22520/2-06	K41	Series II Socket	G
Coax	#16	M22520/2-35	K532-1	Series I, II, III and IV	H
Coax	#12	M22520/2-34	K323	Series I, II, III and IV	I
Quadrax	#24	M22520/2-37	K709	Quadrax Inner Contact	J

Parallel Action Crimp Tool and Hex Die Set



1 Parallel action tool for use with hex crimp dies. 11 inches OAL, 2.0 pounds. Anodized aluminum frame, steel mechanism, plastic handles. Includes tool for die set removal. Accepts all M22520/5 die sets.

2 Die set for terminating coaxial shield to outer contact. Use with size #12 matched impedance M39029/102 and 103 type coaxial contacts. Set consists of upper and lower halves. Made of hardened steel with black oxide finish. Approximately 2 inches in length, assembled. Die set has two closures per illustration.

Figure	Glenair Part Number	Military Part Number	Daniels Part Number	Tool Code
1	809-129	M22520/5-01	HX4	K
2	809-130	M22520/5-03	Y196	L
3	859-007	M22520/5-45	Y143	M

Crimp Tool And Positioner For #12 Coaxial Outer Contact



For crimping size #12 shield sleeves. These mil spec approved tools feature a ratchet mechanism to prevent damage from overcrimping. Check calibration with M22520/3 gage.

1 Crimp tool for use with size #12 coaxial contacts. Black handles. 9.75 inches OAL, 1.25 pounds.

2 Positioner for use with size #12 coaxial contacts. Use with 809-133 (M22520/31-01) crimp tool.

Figure	Glenair Part Number	Military Part Number	Daniels Part Number	Tool Code
1	809-133	M22520/31-01	GS200-1	N
2	809-134	M22520/31-02	G2P330	P

Crimp Tool And Positioner For #16 Coaxial Outer Contact



For crimping size #16 shield sleeves. These mil spec approved tools feature a ratchet mechanism to prevent damage from overcrimping. Check calibration with M22520/3 gage.

1 Crimp tool for use with size #16 coaxial contacts. Blue handles. 9.75 inches OAL, 1.25 pounds.

2 Positioner for use with size #16 coaxial contacts. Use with 809-127 (M22520/4-01) crimp tool.

Figure	Glenair Part Number	Military Part Number	Daniels Part Number	Tool Code
1	809-127	M22520/4-01	GS100-1	Q
2	809-126	M22520/4-02	GP295	R



MIL-DTL-38999 Series I, II, III and IV Pin Contact Selection Guide

AS39029 Pin Contacts										
	Contact Size	Type	Glenair Part Number	Military Part Number	Color Bands			BIN	Wire Size	Tool Code
					1st	2nd	3rd			
38999 Series I, II, III & IV	#10	S	850-002-10-528	M39029/58-528	GREEN	RED	GREY	528	#10 - #12	Consult Factory
		E	850-007-10-624	M39029/107-624	BLUE	RED	YELLOW	624		
	#12	S	850-002-12-365	M39029/58-365	ORANGE	BLUE	GREEN	365	#12 - #14	A, B
		E	850-007-12-623	M39029/107-623	BLUE	RED	ORANGE	623		
		C	852-002-12-211	M39029/28-211	RED	BROWN	BROWN	211	RG174 RG179 RG316	C, I (inner)
		C	852-002-12-409	M39029/28-409	YELLOW	BLACK	WHITE	409	RG180	N, P (outer)
	#16	S	850-002-16-364	M39029/58-364	ORANGE	BLUE	YELLOW	364	#16 - #20	A, B
		E	850-007-16-622	M39029/107-622	BLUE	RED	RED	622		
		C	852-008-16-424	M39029/76-424	YELLOW	RED	YELLOW	424	RG174 RG179 RG316	C, H (inner)
		C	852-008-16-425	M39029/76-425	YELLOW	RED	GREEN	425	RG178	Q, R (outer)
	#20	S	850-002-20-363	M39029/58-363	ORANGE	BLUE	ORANGE	363	#20 - #24	C, D
		E	850-007-20-621	M39029/107-621	BLUE	RED	BROWN	621		
#22D	S	850-002-22-360	M39029/58-360	ORANGE	BLUE	BLACK	360	#22 - #28	C, E	
	E	850-007-22-620	M39029/107-620	BLUE	RED	black	620			

Type	Crimp Style
S	Standard-Duty Crimp
E	Extended-Duty Crimp
C	Coaxial Crimp

BIN Color Coding									
0	1	2	3	4	5	6	7	8	9
BLACK	BROWN	RED	ORANGE	YELLOW	GREEN	BLUE	VIOLET	GREY	WHITE

MIL-DTL-38999
Series I, III and IV
Socket Contact Selection Guide



Environmental
Connectors

AS39029 Socket Contacts										
Contact Size	Type	Glenair Part Number	Military Part Number	Color Bands			BIN	Wire Size	Tool Code	
				1st	2nd	3rd				
#10	S	850-001-10-527	M39029/56-527	GREEN	RED	VIOLET	527	#10 - #12	Consult Factory	
	E	850-006-10-618	M39029/106-618	BLUE	BROWN	GREY	618			
#12	S	850-001-12-353	M39029/56-353	ORANGE	GREEN	ORANGE	353	#12 - #14	A, B	
	E	850-006-12-617	M39029/106-617	BLUE	BROWN	VIOLET	617			
	C	852-003-12-416	M39029/75-416	YELLOW	BROWN	BLUE	416	RG174 RG179 RG316	C, I (inner)	
	C	852-003-12-417	M39029/75-417	YELLOW	BROWN	VIOLET	417	RG180	N, P (outer)	
#16	S	850-001-16-352	M39029/56-352	ORANGE	GREEN	RED	352	#16 - #20	A, B	
	E	850-006-16-616	M39029/106-616	BLUE	BROWN	BLUE	616			
	C	852-009-16-428	M39029/77-428	YELLOW	RED	GREY	428	RG174 RG179 RG316	C, H (inner)	
	C	852-009-16-429	M39029/77-429	YELLOW	RED	WHITE	429	RG178	Q, R (outer)	
#20	S	850-001-20-351	M39029/56-351	ORANGE	GREEN	BROWN	351	#20 - #24	C, D	
	E	850-006-20-615	M39029/106-615	BLUE	BROWN	GREEN	615			
#22D	S	850-001-22-348	M39029/56-348	ORANGE	YELLOW	GREY	348	#22 - #28	C, F	
	E	850-006-22-614	M39029/106-614	BLUE	BROWN	YELLOW	614			

38999 Series I, III & IV

D

Type	Crimp Style
S	Standard-Duty Crimp
E	Extended-Duty Crimp
C	Coaxial Crimp

BIN Color Coding									
0	1	2	3	4	5	6	7	8	9
BLACK	BROWN	RED	ORANGE	YELLOW	GREEN	BLUE	VIOLET	GREY	WHITE



**MIL-DTL-38999
Series II
Socket Contact Selection Guide**

38999 Series II

D

AS39029 Socket Contacts										
Contact Size	Type	Glenair Part Number	Military Part Number	Color Bands			BIN	Wire Size	Tool Code	
				1st	2nd	3rd				
#12	S	850-003-12-359	M39029/57-359	ORANGE	GREEN	WHITE	359	RG174 RG179 RG316	A, B	
	C	852-001-12-210	M39029/27-210	RED	BROWN	BLACK	210		C, I (inner)	
	C	852-001-12-402	M39029/27-402	YELLOW	BLACK	RED	402	RG180	N, P (outer)	
#16	S	850-003-16-358	M39029/57-358	ORANGE	GREEN	GREY	358	#16 - #20	A, B	
	C	852-010-16-432	M39029/78-432	YELLOW	ORANGE	RED	432	RG174 RG179 RG316	C, H (inner)	
	C	852-010-16-433	M39029/78-433	YELLOW	ORANGE	ORANGE	433		RG178	Q, R (outer)
#20	S	850-003-20-357	M39029/57-357	ORANGE	GREEN	VIOLET	357	#20 - #24	C, D	
#22D	S	850-003-22-354	M39029/57-354	ORANGE	GREEN	YELLOW	354	#22 - #28	C, G	

Type	Crimp Style
S	Standard-Duty Crimp
E	Extended-Duty Crimp
C	Coaxial Crimp

BIN Color Coding										
0 BLACK	1 BROWN	2 RED	3 ORANGE	4 YELLOW	5 GREEN	6 BLUE	7 VIOLET	8 GREY	9 WHITE	

233-105-00
MIL-DTL-38999 Series III Type
Wall Mount Environmental Receptacle Connector

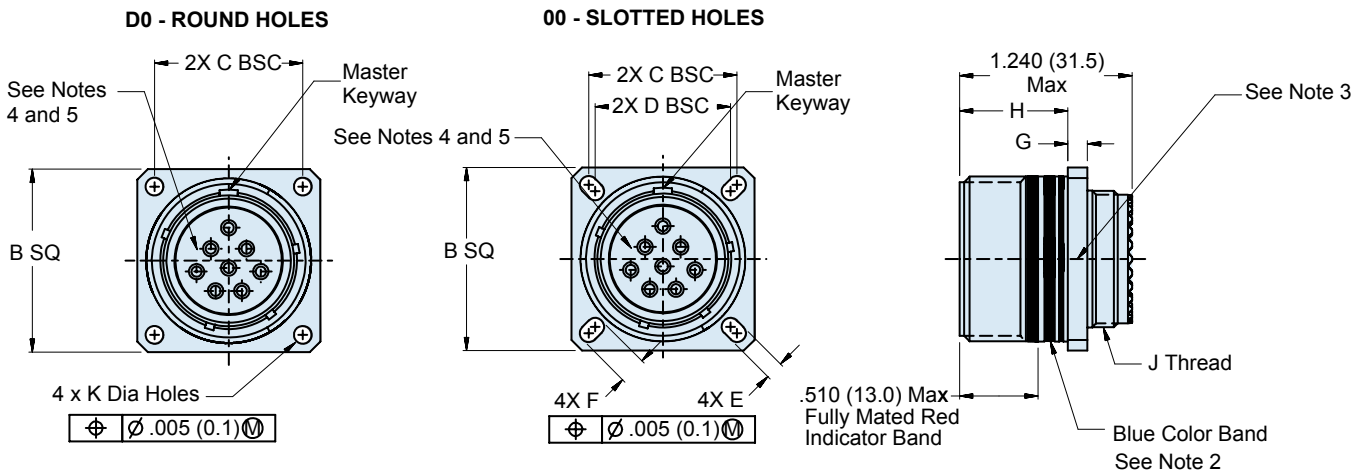
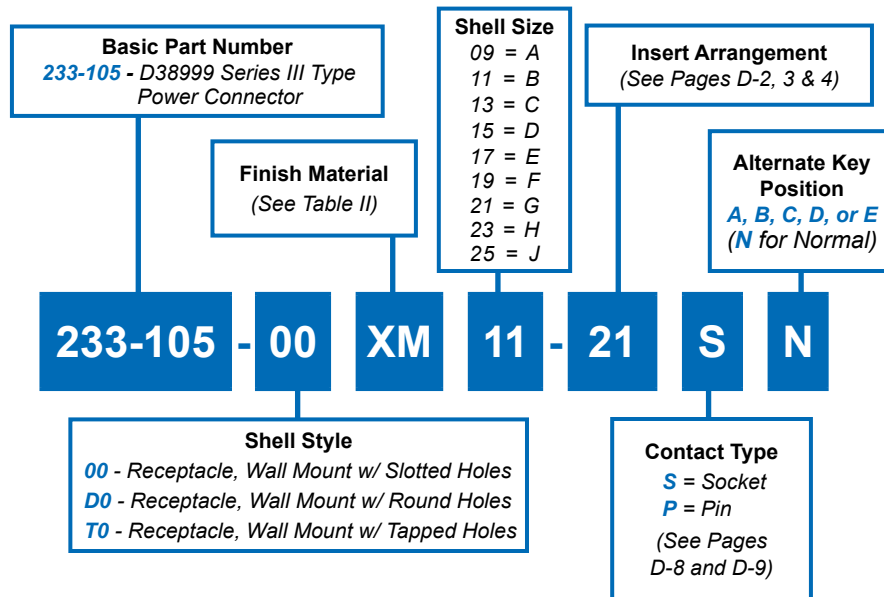

Consult factory for available insert arrangements.

APPLICATION NOTES

1. Material/ Finishes:
 Shells, Jam Nut - See Table II
 (Composite Jam Nut & Composite Coupling Nut No Plating Required).
 Insulators- High Grade Rigid Dielectric/ N.A
 Seals- Fluorosilicone/ N.A.
2. Blue Color Band indicates rear release retention system.
3. Assembly to be identified with Glenair's name, part number and date code space permitting.
4. Insert arrangement in accordance with MIL-STD-1560.
5. Insert arrangement shown is for reference only.
6. Metric dimensions (mm) are in parentheses.



233-105-00
MIL-DTL-38999 Series III Type
Wall Mount Environmental Receptacle Connector

TABLE II: FINISH

SYM	MATERIAL	FINISH	MIL SYM
M	Aluminum	Electroless Nickel	F
NF		Cadmium O.D. Over Electroless Nickel	W
ZN		Zinc Ni, Olive Drab	Z
ZE		Zinc Ni, No Chromate	
ZR		Zinc Ni, Black (Tri-Valent CR)	
AL		Pure-Dense Electro-Deposited Aluminum	P
MT		Ni-PTFE 1000 Hour Grey™	T
XM	Composite	Electroless Nickel	M
XMT		Ni-PTFE 1000 Hour Grey™	
XO		No Finish	
XW		Cadmium O.D. over Electroless Nickel	J
Z1	Stainless Steel	Passivate	
ZC		Zinc Colbalt	
ZL		Electro-Deposited Nickel	
ZW		Cadmium O.D. over Nickel	
AB	Marine Bronze	None (Clean Only)	

*Consult Factory for Additional Plating Options

TABLE III: SHELL SIZE

Shell Size Code	Shell Size	B SQ	C BSC	D BSC	E	F	G	H	J Thread	K Holes Dia
A	09	.949 (24.1)	.719 (18.3)	.594 (15.1)	.136 (3.5)	.224 (5.7)	.144 (3.7)	.820 (20.8)	M12 x 1.0-6g 0.100R	.136 (3.5)
		.925 (23.5)			.120 (0.1)	.208 (5.3)	.083 (2.1)	.768 (19.5)		.120 (3.0)
B	11	1.043 (26.5)	.812 (20.6)	.719 (18.3)	.136 (3.5)	.202 (5.1)	.144 (3.7)	.820 (20.8)	M15 x 1.0-6g 0.100R	.136 (3.5)
		1.019 (25.9)			.120 (0.1)	.188 (4.7)	.083 (2.1)	.768 (19.5)		.120 (3.0)
C	13	1.138 (28.9)	.906 (23.0)	.812 (20.6)	.136 (3.5)	.202 (5.1)	.144 (3.7)	.820 (20.8)	M18 x 1.0-6g 0.100R	.136 (3.5)
		1.114 (28.3)			.120 (0.1)	.188 (4.7)	.083 (2.1)	.768 (19.5)		.120 (3.0)
D	15	1.232 (31.3)	.969 (24.6)	.906 (23.0)	.136 (3.5)	.202 (5.1)	.144 (3.7)	.820 (20.8)	M22 x 1.0-6g 0.100R	.136 (3.5)
		1.208 (30.7)			.120 (0.1)	.208 (5.3)	.083 (2.1)	.768 (19.5)		.120 (3.0)
E	17	1.323 (33.6)	1.062 (27.0)	.969 (24.6)	.136 (3.5)	.202 (5.1)	.144 (3.7)	.820 (20.8)	M25 x 1.0-6g 0.100R	.136 (3.5)
		1.299 (33.0)			.120 (0.1)	.188 (4.7)	.083 (2.1)	.768 (19.5)		.120 (3.0)
F	19	1.449 (36.8)	1.156 (29.4)	1.062 (27.0)	.136 (3.5)	.202 (5.1)	.144 (3.7)	.820 (20.8)	M28 x 1.0-6g 0.100R	.136 (3.5)
		1.425 (36.2)			.120 (0.1)	.188 (4.7)	.083 (2.1)	.768 (19.5)		.120 (3.0)
G	21	1.575 (40.0)	1.250 (31.8)	1.156 (29.4)	.136 (3.5)	.202 (5.1)	.171 (65.2)	.790 (20.1)	M31 x 1.0-6g 0.100R	.136 (3.5)
		1.551 (39.4)			.120 (0.1)	.188 (4.7)	.083 (39.8)	.736 (18.7)		.120 (3.0)
H	23	1.701 (43.2)	1.375 (34.9)	1.250 (31.8)	.162 (4.1)	.250 (6.4)	.171 (65.2)	.790 (20.1)	M34 x 1.0-6g 0.100R	.162 (4.1)
		1.677 (42.6)			.146 (3.7)	.234 (5.9)	.083 (39.8)	.736 (18.7)		.146 (3.7)
J	25	1.823 (46.3)	1.500 (38.1)	1.375 (34.9)	.162 (4.1)	.250 (6.4)	.171 (65.2)	.790 (20.1)	M37 x 1.0-6g 0.100R	.162 (4.1)
		1.799 (45.7)			.146 (3.7)	.234 (5.9)	.083 (39.8)	.736 (18.7)		.146 (3.7)

233-105-00
MIL-DTL-38999 Series III Type
Wall Mount Environmental Receptacle Connector

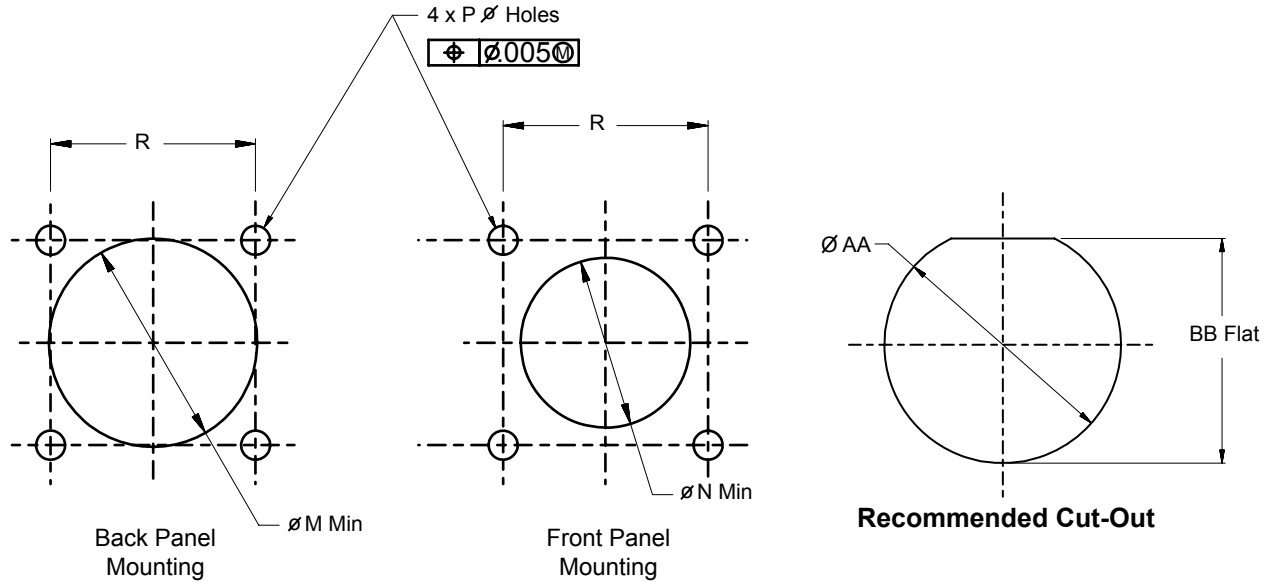

**Recommended Mounting Holes
for Wall Mount Receptacle**

TABLE IV: SHELL SIZE							
Shell Size Code	Shell Size	AA Dia	BB Flat	M Ø Min	N Ø Min	P Ø Holes	R BSC
A	09	.703 (17.9)	.657 (16.7)	.656 (16.7)	.516 (13.1)	.133 (3.4)	.719 (18.3)
		.693 (17.6)	.655 (16.6)			.123 (3.1)	
B	11	.835 (21.2)	.771 (19.6)	.796 (20.2)	.625 (15.9)	.133 (3.4)	.812 (20.6)
		.825 (21.0)	.769 (19.5)			.123 (3.1)	
C	13	1.020 (25.9)	.955 (24.3)	.922 (23.4)	750 (19.1)	.133 (3.4)	.906 (23.0)
		1.010 (25.7)	.943 (24.0)			.123 (3.1)	
D	15	1.145 (29.1)	1.085 (27.6)	1.047 (26.6)	.906 (23.0)	.133 (3.4)	.969 (24.6)
		1.135 (28.8)	1.083 (27.5)			.123 (3.1)	
E	17	1.270 (32.3)	1.210 (30.7)	1.219 (31.0)	1.016 (25.8)	.133 (3.4)	1.062 (27.0)
		1.260 (32.0)	1.208 (30.7)			.123 (3.1)	
F	19	1.395 (35.4)	1.335 (33.9)	1.297 (32.9)	1.141 (29.0)	.133 (3.4)	1.156 (29.4)
		1.385 (35.2)	1.333 (33.9)			.123 (3.1)	
G	21	1.520 (38.6)	1.460 (37.1)	1.422 (36.1)	1.266 (32.2)	.133 (3.4)	1.250 (31.8)
		1.510 (38.4)	1.458 (37.0)			.123 (3.1)	
H	23	1.645 (41.8)	1.585 (40.3)	1.547 (39.3)	1.375 (34.9)	.159 (4.0)	1.375 (34.9)
		1.635 (41.5)	1.583 (40.2)			.149 (3.8)	
J	25	1.770 (45.0)	1.710 (43.4)	1.672 (42.5)	1.484 (37.7)	.155 (3.9)	1.500 (38.1)
		1.760 (44.7)	1.708 (43.4)			.145 (3.7)	

Metric dimensions (mm) are indicated in parentheses

233-105-07 MIL-DTL-38999 Series III Type Jam Nut Environmental Receptacle Connector

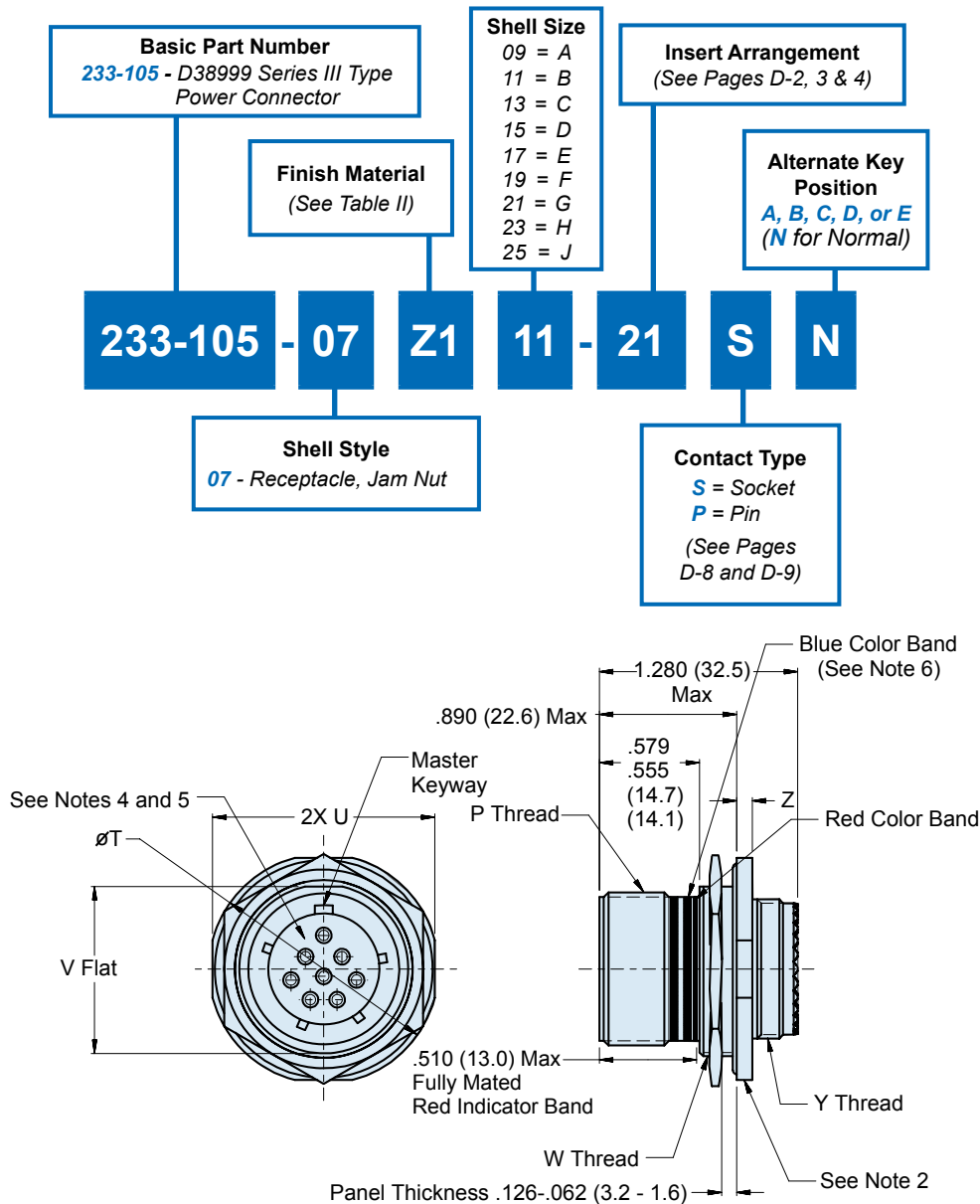

Consult factory for available insert arrangements.

APPLICATION NOTES

- Material/ Finishes:
Shells, Jam Nut - See Table II
(Composite Jam Nut No Plating Required).
Insulators- High Grade Rigid Dielectric/ N.A
Seals- Fluorosilicone/ N.A.
- Assembly to be identified with Glenair's name, part number and date code space permitting.
- Modified major diameter 1.252-1.257 (31.80-31.95).
- Insert arrangement in accordance with MIL-STD-1560.
- Insert arrangement shown is for reference only.
- Blue Color Band indicates rear release retention system.
- Metric dimensions (mm) are in parentheses.

233-105-07
MIL-DTL-38999 Series III Type
Jam Nut Environmental Receptacle Connector



TABLE II: FINISH			
SYM	MATERIAL	FINISH	MIL SYM
M	Aluminum	Electroless Nickel	F
NF		Cadmium O.D. Over Electroless Nickel	W
ZN		Zinc Ni, Olive Drab	Z
ZE		Zinc Ni, No Chromate	
ZR		Zinc Ni, Black (Tri-Valent CR)	
AL		Pure-Dense Electro-Deposited Aluminum	P
MT		Ni-PTFE 1000 Hour Grey™	T
XM	Composite	Electroless Nickel	M
XMT		Ni-PTFE 1000 Hour Grey™	
XO		No Finish	
XW		Cadmium O.D. over Electroless Nickel	J
Z1	Stainless Steel	Passivate	
ZC		Zinc Colbalt	
ZL		Electro-Deposited Nickel	
ZW		Cadmium O.D. over Nickel	
AB	Marine Bronze	None (Clean Only)	

*Consult Factory for Additional Plating Options

TABLE III: SHELL SIZE								
Shell Size Code	Shell Size	P Thread	T Dia	U	V	W Thread	Y Thread	Z
A	09	.6250-.1P-.3L-TS-2A	1.200 (30.5) 1.178 (29.9)	1.078 (27.4) 1.048 (26.6)	.654 (16.6) .645 (16.4)	M17 x 1.0-6g 0.100R	M12 x 1.0-6g 0.100R	.122 (3.1) .083 (2.1)
B	11	.7500-.1P-.3L-TS-2A	1.386 (35.2) 1.362 (34.6)	1.268 (32.2) 1.236 (31.4)	.755 (19.2) .745 (18.9)	M20 x 1.0-6g 0.100R	M15 x 1.0-6g 0.100R	
C	13	.8750-.1P-.3L-TS-2A	1.512 (38.4) 1.488 (37.8)	1.390 (35.3) 1.358 (34.5)	.942 (23.9) .932 (23.7)	M25 x 1.0-6g 0.100R	M18 x 1.0-6g 0.100R	
D	15	1.0000-.1P-.3L-TS-2A	1.638 (41.6) 1.614 (41.0)	1.516 (38.5) 1.484 (37.7)	1.066 (27.1) 1.056 (26.8)	M28 x 1.0-6g 0.100R	M22 x 1.0-6g 0.100R	
E	17	1.1875-.1P-.3L-TS-2A	1.764 (44.8) 1.740 (44.2)	1.642 (41.7) 1.610 (40.9)	1.191 (30.3) 1.181 (30.0)	M32 x 1.0-6g 0.100R*	M25 x 1.0-6g 0.100R	
F	19	1.2500-.1P-.3L-TS-2A	1.949 (49.5) 1.925 (48.9)	1.827 (46.4) 1.795 (45.6)	1.316 (33.4) 1.306 (33.2)	M35 x 1.0-6g 0.100R	M28 x 1.0-6g 0.100R	.153 (3.9) .114 (2.9)
G	21	1.3750-.1P-.3L-TS-2A	2.075 (52.7) 2.051 (52.1)	1.953 (49.6) 1.921 (48.8)	1.441 (36.6) 1.431 (36.3)	M38 x 1.0-6g 0.100R	M31 x 1.0-6g 0.100R	
H	23	1.5000-.1P-.3L-TS-2A	2.201 (55.9) 2.177 (55.3)	2.079 (52.8) 2.047 (52.0)	1.566 (39.8) 1.556 (39.5)	M41 x 1.0-6g 0.100R	M34 x 1.0-6g 0.100R	
J	25	1.6250-.1P-.3L-TS-2A	2.323 (59.0) 2.299 (58.4)	2.205 (56.0) 2.173 (55.2)	1.691 (43.0) 1.681 (42.7)	M44 x 1.0-6g 0.100R	M37 x 1.0-6g 0.100R	

*See Note 3





233-105-05
MIL-DTL-38999 Series III Type
In-Line Environmental Receptacle Connector

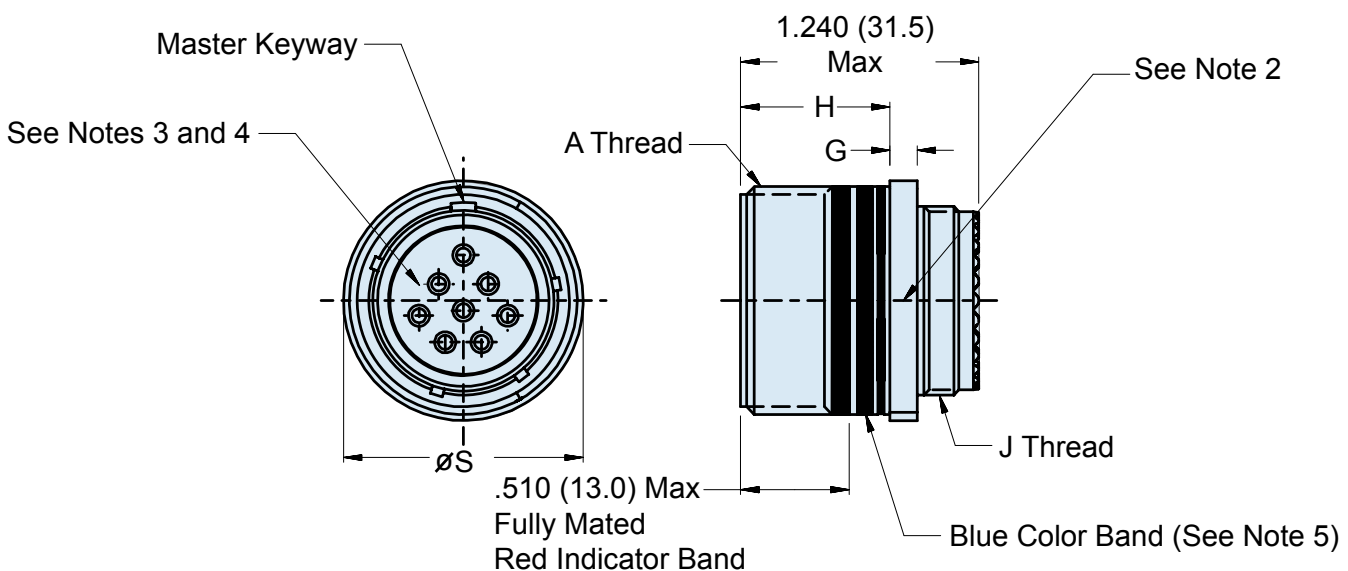
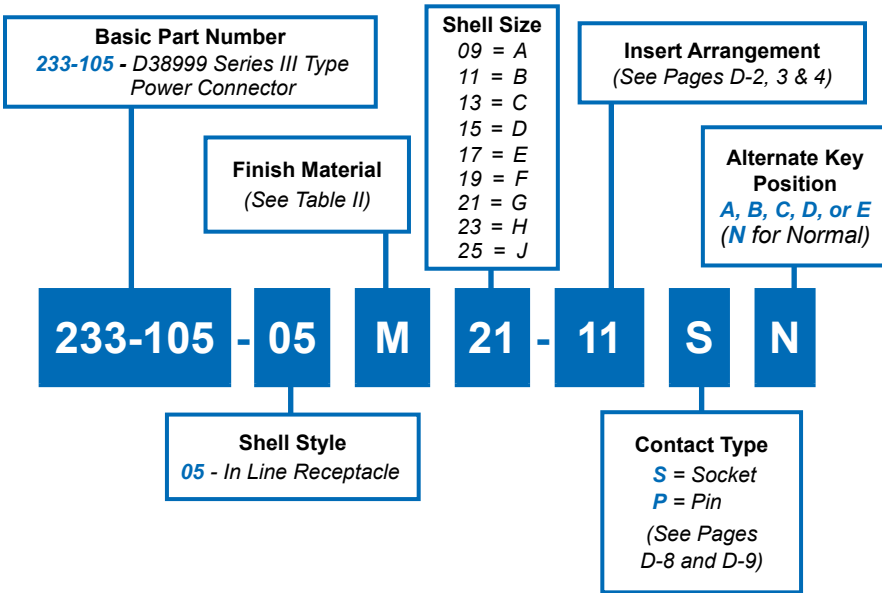

Consult factory for available insert arrangements.

APPLICATION NOTES

- | | |
|---|---|
| <p>1. Material/ Finishes:
 Shells - See Table II
 Insulator- High Grade Rigid Dielectric/ N.A
 Seals- Fluorosilicone/ N.A.</p> <p>2. Assembly to be identified with Glenair's name, part number and date code space permitting.</p> | <p>3. Insert arrangement in accordance with MIL-STD-1560.</p> <p>4. Insert arrangement shown is for reference only.</p> <p>5. Blue Color Band indicates rear release retention system.</p> <p>7. Metric Dimensions (mm) are indicated in parentheses.</p> |
|---|---|

233-105-05
MIL-DTL-38999 Series III Type
In-Line Environmental Receptacle Connector



TABLE II: FINISH			
SYM	MATERIAL	FINISH	MIL SYM
M	Aluminum	Electroless Nickel	F
NF		Cadmium O.D. Over Electroless Nickel	W
ZN		Zinc Ni, Olive Drab	Z
ZE		Zinc Ni, No Chromate	
ZR		Zinc Ni, Black (Tri-Valent CR)	
AL		Pure-Dense Electro-Deposited Aluminum	P
MT		Ni-PTFE 1000 Hour Grey™	T
XM		Composite	Electroless Nickel
XMT	Ni-PTFE 1000 Hour Grey™		
XO	No Finish		
XW	Cadmium O.D. over Electroless Nickel		J
Z1	Stainless Steel	Passivate	
ZC		Zinc Colbalt	
ZL		Electro-Deposited Nickel	
ZW		Cadmium O.D. over Nickel	
AB	Marine Bronze	None (Clean Only)	

*Consult Factory for Additional Plating Options

TABLE III: SHELL SIZE						
Shell Size Code	Shell Size	A Thread	G	H	S Max Dia	J Thread
A	09	.6250-.1P-.3L-TS-2A	.144 (3.7) .083 (2.1)	.823 (20.9) .768 (19.5)	.858 (21.8)	M12 x 1.0-6g 0.100R
B	11	.7500-.1P-.3L-TS-2A	.144 (3.7) .083 (2.1)	.823 (20.9) .768 (19.5)	.984 (25.0)	M15 x 1.0-6g 0.100R
C	13	.8750-.1P-.3L-TS-2A	.144 (3.7) .083 (2.1)	.823 (20.9) .768 (19.5)	1.157 (29.4)	M18 x 1.0-6g 0.100R
D	15	1.0000-.1P-.3L-TS-2A	.144 (3.7) .083 (2.1)	.823 (20.9) .768 (19.5)	1.280 (32.5)	M22 x 1.0-6g 0.100R
E	17	1.1875-.1P-.3L-TS-2A	.144 (3.7) .083 (2.1)	.823 (20.9) .768 (19.5)	1.406 (35.7)	M25 x 1.0-6g 0.100R
F	19	1.2500-.1P-.3L-TS-2A	.144 (3.7) .083 (2.1)	.823 (20.9) .768 (19.5)	1.516 (38.5)	M28 x 1.0-6g 0.100R
G	21	1.3750-.1P-.3L-TS-2A	.171 (65.2) .083 (39.8)	.791 (20.0) .736 (18.7)	1.642 (41.7)	M31 x 1.0-6g 0.100R
H	23	1.5000-.1P-.3L-TS-2A	.171 (65.2) .083 (39.8)	.791 (20.0) .736 (18.7)	1.768 (44.9)	M34 x 1.0-6g 0.100R
J	25	1.6250-.1P-.3L-TS-2A	.171 (65.2) .083 (39.8)	.791 (20.0) .736 (18.7)	1.890 (48.0)	M37 x 1.0-6g 0.100R





233-105-G6 MIL-DTL-38999 Series III Type Environmental Plug Connector

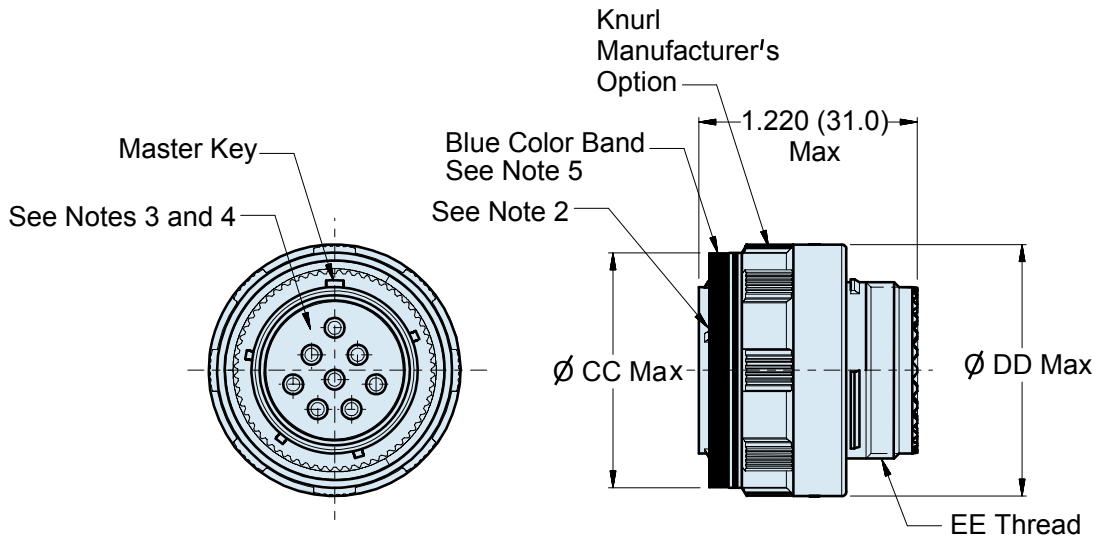
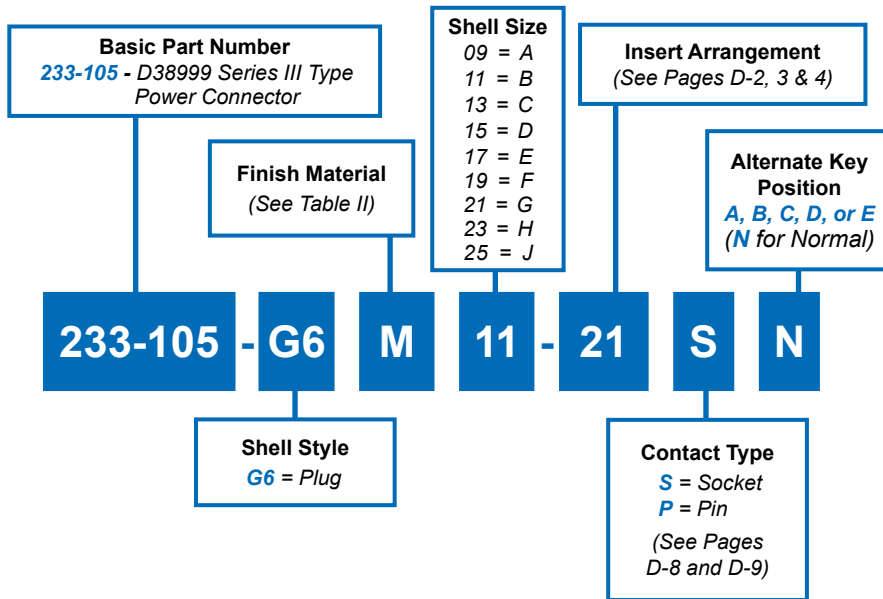

Consult factory for available insert arrangements.

APPLICATION NOTES

1. Material/ Finishes:
Barrel, Coupling Nut - See Table II
(Composite Coupling Nut - No Plating Required).
Insulators- High Grade Rigid Dielectric/ N.A.
Seals- Fluorosilicone/ N.A.
2. Assembly to be identified with Glenair's name, part number and date code space permitting.
3. Insert arrangement in accordance with MIL-STD-1560.
4. Insert arrangement shown is for reference only.
5. Blue Color Band indicates rear release retention system.
7. Metric Dimensions (mm) are indicated in parentheses.

233-105-G6
MIL-DTL-38999 Series III Type
Environmental Plug Connector



TABLE II: FINISH			
SYM	MATERIAL	FINISH	MIL SYM
M	Aluminum	Electroless Nickel	F
NF		Cadmium O.D. Over Electroless Nickel	W
ZN		Zinc Ni, Olive Drab	Z
ZE		Zinc Ni, No Chromate	
ZR		Zinc Ni, Black (Tri-Valent CR)	
AL		Pure-Dense Electro-Deposited Aluminum	P
MT		Ni-PTFE 1000 Hour Grey™	T
XM	Composite	Electroless Nickel	M
XMT		Ni-PTFE 1000 Hour Grey™	
XO		No Finish	
XW		Cadmium O.D. over Electroless Nickel	J
Z1	Stainless Steel	Passivate	
ZC		Zinc Colbalt	
ZL		Electro-Deposited Nickel	
ZW		Cadmium O.D. over Nickel	
AB	Marine Bronze	None (Clean Only)	

*Consult Factory for Additional Plating Options

D

TABLE III: SHELL SIZE				
Shell Size Code	Shell Size	CC Max Dia	DD Max Dia	EE Thread
A	09	.811 (20.6)	.858 (21.8)	M12 x 1.0-6g 0.100R
B	11	.929 (23.6)	.984 (25.0)	M15 x 1.0-6g 0.100R
C	13	1.110 (28.2)	1.157 (29.4)	M18 x 1.0-6g 0.100R
D	15	1.232 (31.3)	1.280 (32.5)	M22 x 1.0-6g 0.100R
E	17	1.358 (34.5)	1.406 (35.7)	M25 x 1.0-6g 0.100R
F	19	1.469 (37.3)	1.516 (38.5)	M28 x 1.0-6g 0.100R
G	21	1.594 (40.5)	1.642 (41.7)	M31 x 1.0-6g 0.100R
H	23	1.720 (43.7)	1.768 (44.9)	M34 x 1.0-6g 0.100R
J	25	1.843 (46.8)	1.890 (48.0)	M37 x 1.0-6g 0.100R

947-050
Jam Nut Mount Shorting Receptacle
MIL-DTL-38999 Series I Type

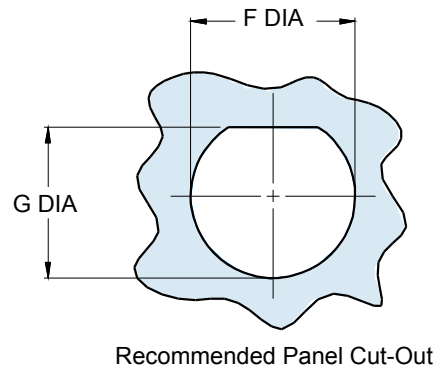
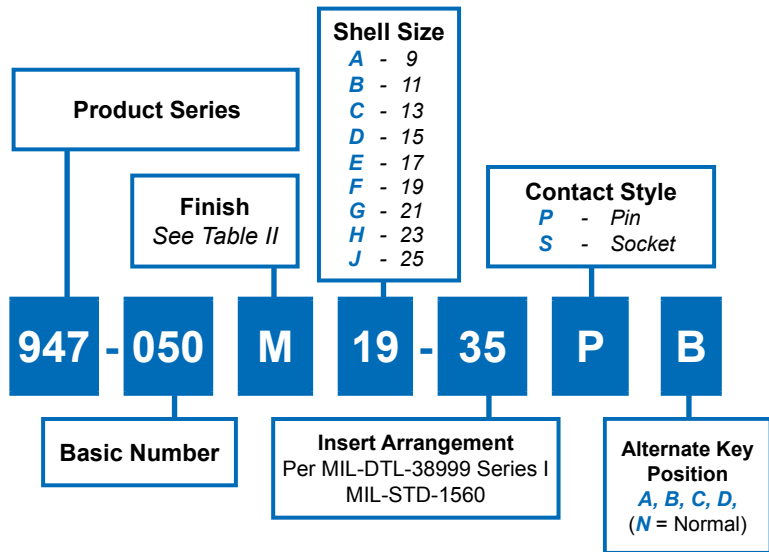

D

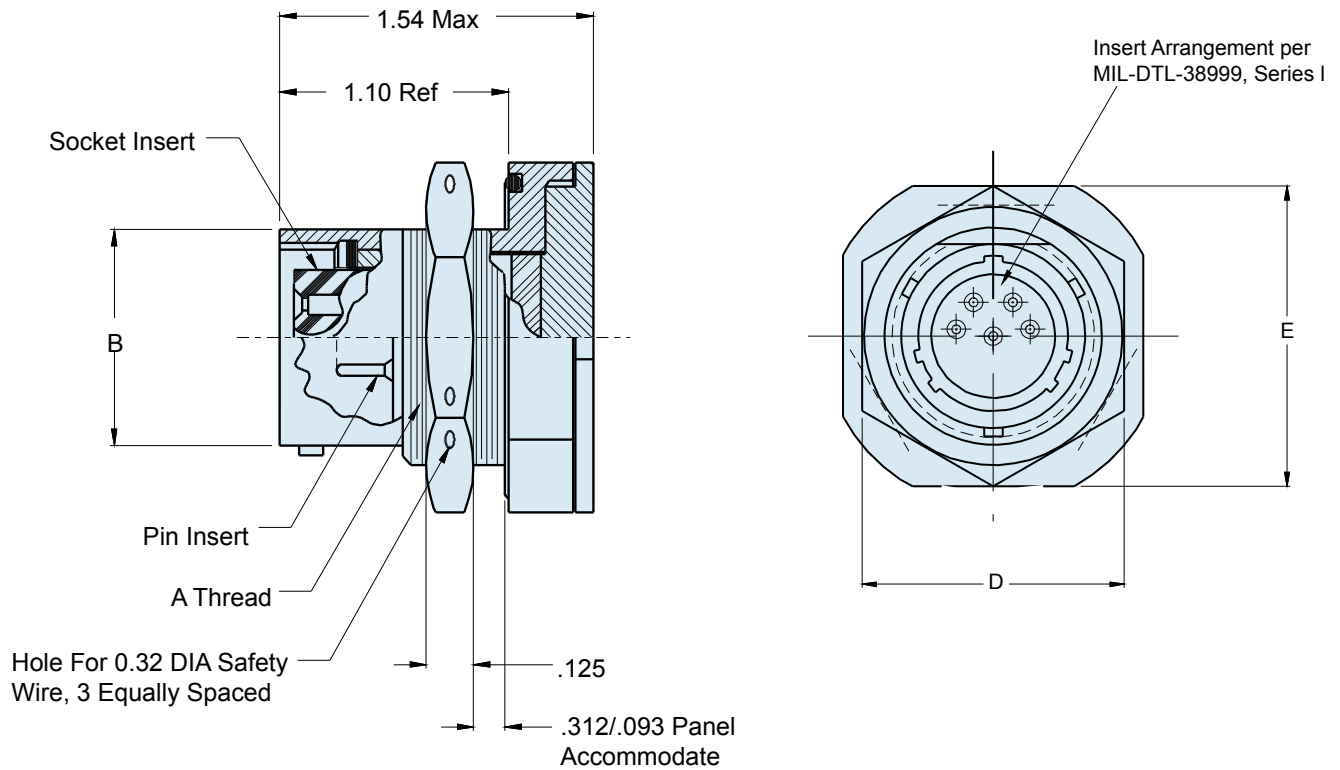

947-050
Jam Nut Mount Shorting Receptacle
MIL-DTL-38999 Series I Type



TABLE I: CONNECTOR DIMENSIONS

SHELL SIZE	A THREAD CLASS 2A	B DIA MAX	D HEX	E FLATS	F DIA ±.005(0.1)	G +.000-.005 (0-0.1)
09	11/16-24 UNEF	.573(14.6)	.875(22.2)	1.062(27.0)	.703(17.9)	.699(17.8)
11	13/16-20 UNEF	.701(17.8)	1.000(25.4)	1.250(31.8)	.827(21.0)	.769(19.5)
13	1 -20 UNEF	.851(21.6)	1.188(30.2)	1.375(34.9)	1.015(25.8)	.955(24.3)
15	1 1/8-18 UNEF	.976(24.8)	1.312(33.3)	1.500(38.1)	1.140(29.0)	1.084(27.5)
17	1 1/4-18 UNEF	1.101(28.0)	1.438(36.5)	1.625(41.3)	1.265(32.1)	1.208(30.7)
19	1 3/8-18 UNEF	1.208(30.7)	1.562(39.7)	1.812(46.0)	1.390(35.3)	1.333(33.9)
21	1 1/2-18 UNEF	1.333(33.9)	1.688(42.9)	1.938(49.2)	1.515(38.5)	1.459(37.1)
23	1 5/8-18 UNEF	1.458(37.0)	1.812(46.0)	2.062(52.4)	1.640(41.7)	1.580(40.1)
25	1 3/4-18 UNS	1.583(40.2)	2.000(50.8)	2.188(55.6)	1.765(44.8)	1.709(43.4)

TABLE II: FINISH

SYM	MATERIAL	FINISH
A	Aluminum	Cadmium Plate/Bright Dip
B		Cadmium Plate/Olive Drab
E		Gold Iridite
J		Gold Iridite over Cadmium Plate over Nickel Plate
L		Cadmium Plate/Olive Drab over Nickel Plate (500-Hour Salt Spray)
M		Electroless Nickel
N		Cadmium Plate/Olive Drab over Nickel Plate
NF		Cadmium Plate/Olive Drab over Nickel Plate (500 Hour Salt Spray)
P		Nickel Plate
T		Cadmium Plate over Nickel Plate
W		Leached Iridite
Y		Gold Iridite over Cadmium Plate
Z		Special per Purchase Order

*Consult Factory for Additional Plating Options

APPLICATION NOTES

1. Assembly identified with manufacturer's name and part number, space permitting.
2. Material/finish:
Shell assembly, jam nut, locking coupling nut—aluminum alloy/
see Table II
Contacts—copper alloy/gold plate
3. Insulators—high grade dielectric/N.A.
Bayonet pins—CRES/passivate
Ground wafer—copper/tin plate
Conductive seal—Consil II/N.A.
Metric Dimensions (mm) are indicated in parentheses.





GC487 Shorting Bulkhead Feed-Thru MIL-DTL-38999 Series I Type

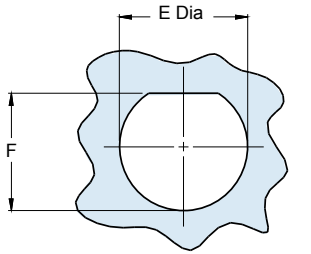
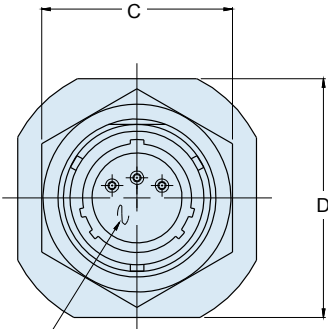
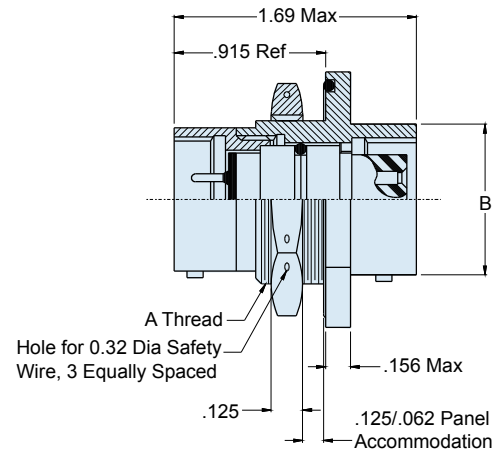
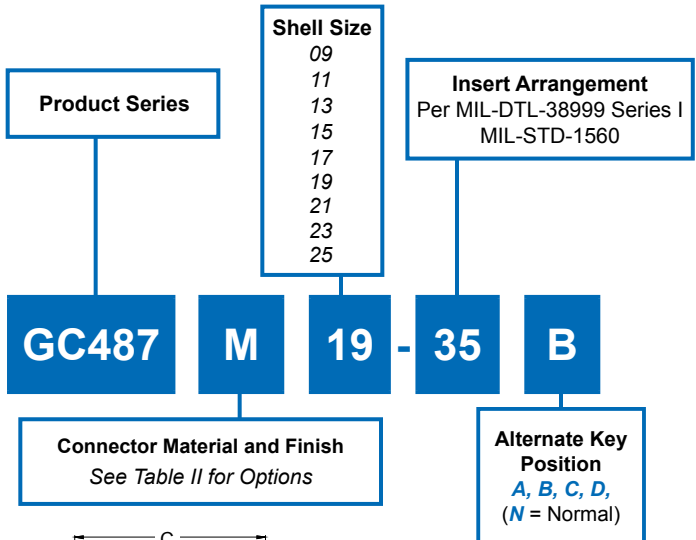

Insert Arrangement, per MIL-C-38999, Series I

Recommended Panel Cut-Out

TABLE II: FINISH	
SYM	FINISH
M	Electroless Nickel
MT	Ni-PTFE 1000 Hour Grey™ (Nickel-Fluorocarbon Polymer)
NF	Cadmium O.D. Over Electroless Nickel
N	Cadmium O.D. Over Nickel Plate

TABLE I: CONNECTOR DIMENSIONS						
SHELL SIZE	A THREAD CLASS 2A	B DIA MAX	C HEX	D FLATS	E DIA ±.005(0.1)	F +.000-.005 (0-0.1)
09	11/16-24 UNEF	.573(14.6)	.875(22.2)	1.062(27.0)	.703(17.9)	.669(17.0)
11	13/16-20 UNEF	.701(17.8)	1.000(25.4)	1.250(31.8)	.827(21.0)	.769(19.5)
13	1 -20 UNEF	.851(21.6)	1.188(30.2)	1.375(34.9)	1.015(25.8)	.955(24.3)
15	1 1/8-18 UNEF	.976(24.8)	1.312(33.3)	1.500(38.1)	1.140(29.0)	1.084(27.5)
17	1 1/4-18 UNEF	1.101(28.0)	1.438(36.5)	1.625(41.3)	1.265(32.1)	1.208(30.7)
19	1 3/8-18 UNEF	1.208(30.7)	1.562(39.7)	1.812(46.0)	1.390(35.3)	1.333(33.9)
21	1 1/2-18 UNEF	1.333(33.9)	1.688(42.9)	1.938(49.2)	1.515(38.5)	1.459(37.1)
23	1 5/8-18 UNEF	1.458(37.0)	1.812(46.0)	2.062(52.4)	1.640(41.7)	1.580(40.1)
25	1 3/4-18 UNS	1.583(40.2)	2.000(50.8)	2.188(55.6)	1.765(44.8)	1.709(43.4)

APPLICATION NOTES	
1. Assembly identified with manufacturer's name and part number, space permitting 2. Material/finish: Shell assembly, jam nut, lock ring—al alloy/see Table II	Contacts—copper alloy/gold plate Bayonet pins—CRES/passivate O-rings, interfacial & peripheral seals—silicone/N.A. Insulators—high grade rigid dielectric/ N.A. 3. Metric Dimensions (mm) are indicated in parentheses

250-005
Shorting Plug
MIL-DTL-38999 Series II Type

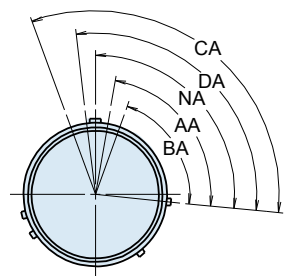
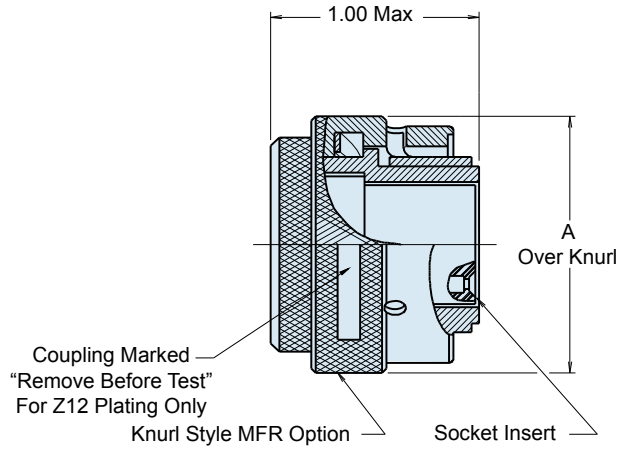
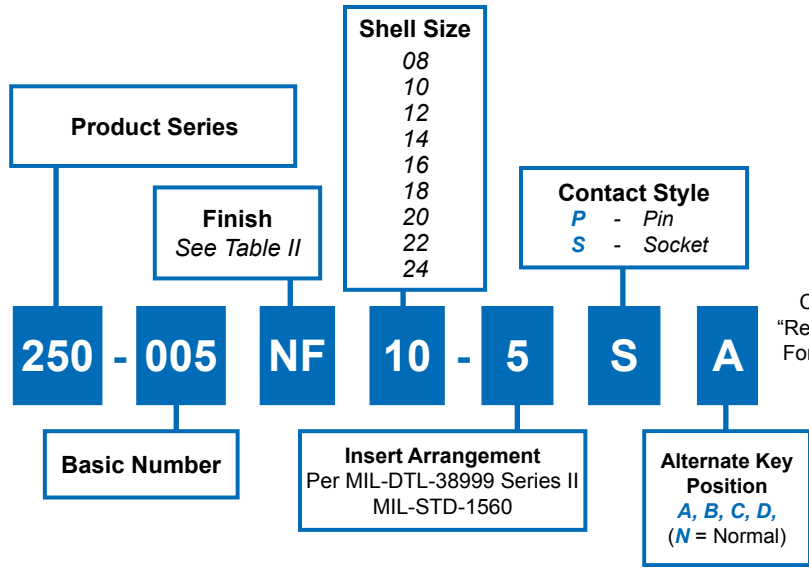

Figure 1
 Master Keyway Position
 Face View Shown
 Insert Arrangement Does
 Not Rotate With Master Keyway



TABLE I: CONNECTOR DIMENSIONS						
SHELL SIZE	A MAX	ALTERNATE KEYWAY POSITIONS				
		NA	AA	BA	CA	DA
08	.750(19.1)	100A	82A	-	-	118A
10	.859(21.8)	100A	86A	72A	128A	114A
12	1.031(26.2)	100A	80A	68A	132A	120A
14	1.156(29.4)	100A	79A	66A	134A	121A
16	1.281(32.5)	100A	82A	70A	130A	118A
18	1.406(35.7)	100A	82A	72A	130A	118A
20	1.531(38.9)	100A	82A	70A	130A	118A
22	1.641(41.7)	100A	85A	74A	126A	115A
24	1.766(44.9)	100A	85A	74A	126A	115A

TABLE II: FINISH	
SYM	FINISH
M	Electroless Nickel
MT	Ni-PTFE 1000 Hour Grey™ (Nickel-Fluorocarbon Polymer)
NF	Cadmium O.D. Over Electroless Nickel
N	Cadmium O.D. Over Nickel Plate

APPLICATION NOTES

1. Assembly identified with manufacturer's name, part number and date code.
2. All contacts are shorted to each other and to the shell, max resistance between contacts and shall shall be 2.5 milliohms.
3. Material/Finish:
 Barrel, coupling nut, cover—aluminum alloy/see Table II
 Contacts, grounding ring—copper alloy/gold plate
 Grounding wafer—copper/tin plate
 Wave washer—CRES/passivate
 Insulators—high grade rigid dielectric/N.A.
4. Metric Dimensions (mm) are indicated in parentheses.

947-150 Quick Disconnect Plug Connector MIL-DTL-38999 Series III Type

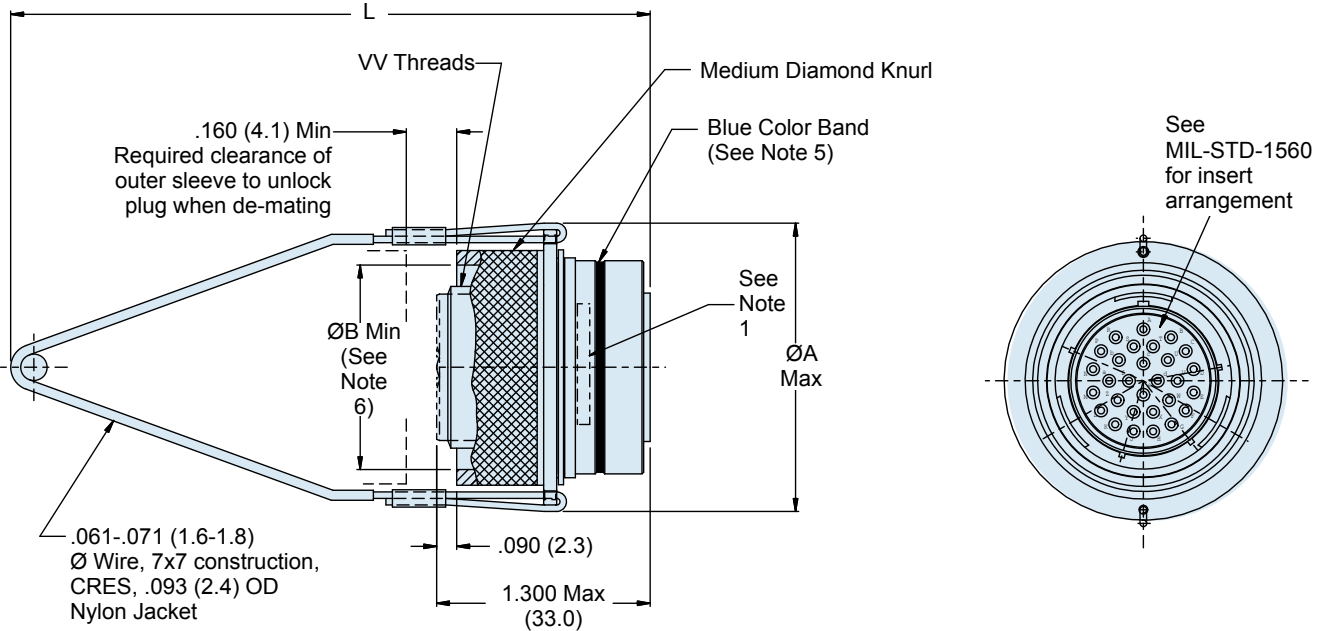
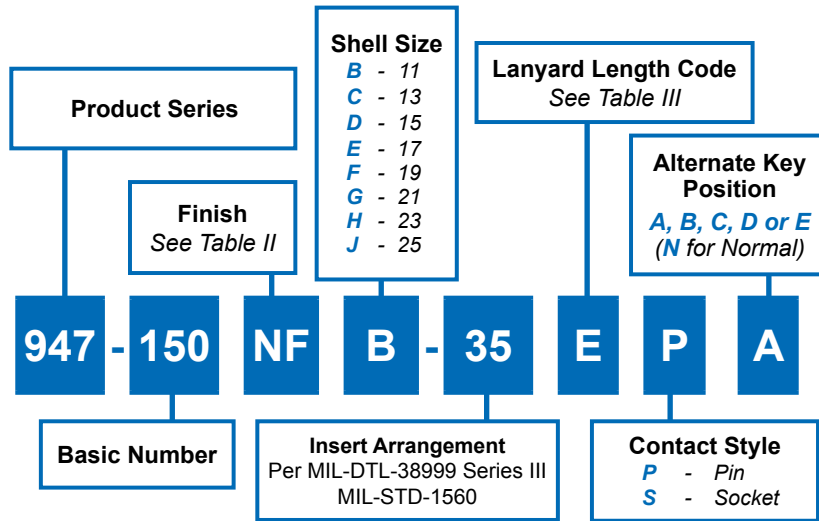

TABLE I: CONNECTOR DIMENSIONS

Shell Size	Shell Size Code	A Max	B Min	W Thread
09	A	1.720 (43.7)	.977 (24.8)	M12x1-6g-0.100R
11	B	1.746 (44.3)	1.003 (25.5)	M15x1-6g-0.100R
13	C	1.872 (47.5)	1.177 (29.9)	M18x1-6g-0.100R
15	D	2.104 (53.4)	1.299 (33.0)	M22x1-6g-0.100R
17	E	2.204 (56.0)	1.425 (36.2)	M25x1-6g-0.100R
19	F	2.230 (56.5)	1.535 (39.0)	M28x1-6g-0.100R
21	G	2.472 (62.8)	1.661 (42.2)	M31x1-6g-0.100R
23	H	2.374 (60.2)	1.787 (45.4)	M34x1-6g-0.100R
25	J	2.494 (63.3)	1.909 (48.5)	M37x1-6g-0.100R

TABLE II: FINISH

SYM	FINISH
M	Electroless Nickel
Z1	CRES, Passivated
ZL	CRES, Electrodeposited Nickel
MT	Ni-PTFE 1000 Hour Grey™ (Nickel-Fluorocarbon Polymer)
NF	Cadmium O.D. Over Electroless Nickel
N	Cadmium O.D. Over Nickel Plate

947-150
Quick Disconnect Plug Connector
MIL-DTL-38999 Series III Type



TABLE III: LANYARD LENGTH CODE

CODE	L ± .236 (±6)	CODE	L ± .236 (±6)	CODE	L ± .236 (±6)	CODE	L ± .236 (±6)
A	4.016 (102)	G	7.007 (178)	M	10.000 (254)	U	13.031 (331)
B	4.527 (115)	H	7.519 (191)	N	10.511 (267)	V	14.015 (356)
C	5.000 (127)	I	7.992 (203)	P	11.023 (280)	W	15.000 (381)
D	5.511 (140)	J	8.503 (216)	R	11.535 (293)	X	16.023 (407)
E	6.024 (153)	K	9.015 (229)	S	12.007 (305)	Y	17.007 (432)
F	6.535 (166)	L	9.527 (242)	T	12.519 (318)	Z	18.031 (458)

TABLE IV: SEPARATION FORCES MAX

SHELL SIZE	STRAIGHT PULL [NEWTON]	15 DEGREE PULL [NEWTON]
09	44.96 LBS [200]	55.08 LBS [245]
11	44.96 LBS [200]	55.08 LBS [245]
13	44.96 LBS [200]	55.08 LBS [245]
15	44.96 LBS [200]	55.08 LBS [245]
17	89.92 LBS [400]	100.04 LBS [445]
19	89.92 LBS [400]	100.04 LBS [445]
21	89.92 LBS [400]	100.04 LBS [445]
23	89.92 LBS [400]	100.04 LBS [445]
25	89.92 LBS [400]	100.04 LBS [445]

TABLE V: SUPPLIED COMPONENTS

Contact Size	Contact Pin P/N	Contact Socket P/N	Sealing Plug P/N	Insert/Remove Tool P/N
22D	M39029/58-360	M39029/56-348	M27488-22	M81969/14-01
20	M39029/58-363	M39029/56-351	M27488-20	M81969/14-10
16	M39029/58-364	M39029/56-352	M27488-16	M81969/14-03
12	M39029/58-365	M39029/56-353	M27488-12	M81969/14-04
12	M39029/102-558 COAX	M39029/103-559 COAX	M27488-12	M81969/14-04
8	M39029/60-367 COAX	M39029/59-366 COAX	M27488-8	M81969/14-06
8	M39029/90-529 TWINAX	M39029/91-530 TWINAX	M27488-8	M81969/14-06

APPLICATION NOTES

- Assembly to be identified with Glenair's name and part number.
- Material/finishes:
 Shell, coupling sleeve, lanyard ring,
 Inner sleeve, locking—al alloy or CRES/see Table II
 Contacts—copper alloy/gold plate (purchased separately)
 Insulators—high grade rigid dielectric/N.A.
 Seals—fluorosilicone/ N.A.
- This connector mates with MIL-DTL-38999/20, /21, /23, /24, /25, and /27.
- Dimensions in parenthesis are metric and for reference.
- Blue color band indicates rear release retention system.
- Dim B is clearance to accommodate AS85049 accessories.
- For backshell extender consult factory.
- Contacts, insertion/removal tools and sealing plugs are purchased separately. For more information please see catalog introduction.
- Metric dimensions (mm) are indicated in parentheses.



233-101-G6
Type 4 Lanyard Release Plug for MIL-STD-1760
 and Other MIL-DTL-38999 Series III Type
 Hybrid Signal, Power, Coax and Twinax Arrangements

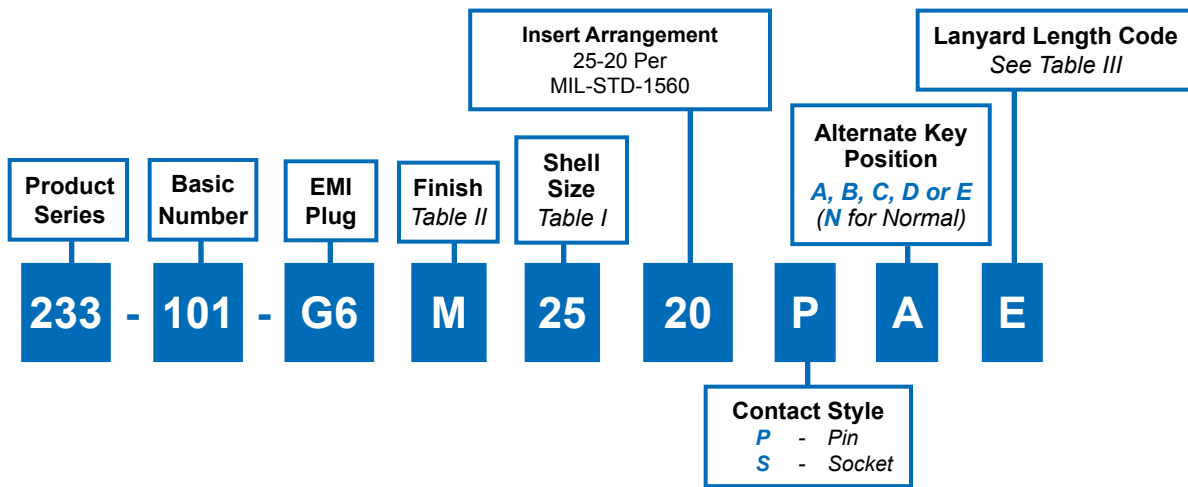

D

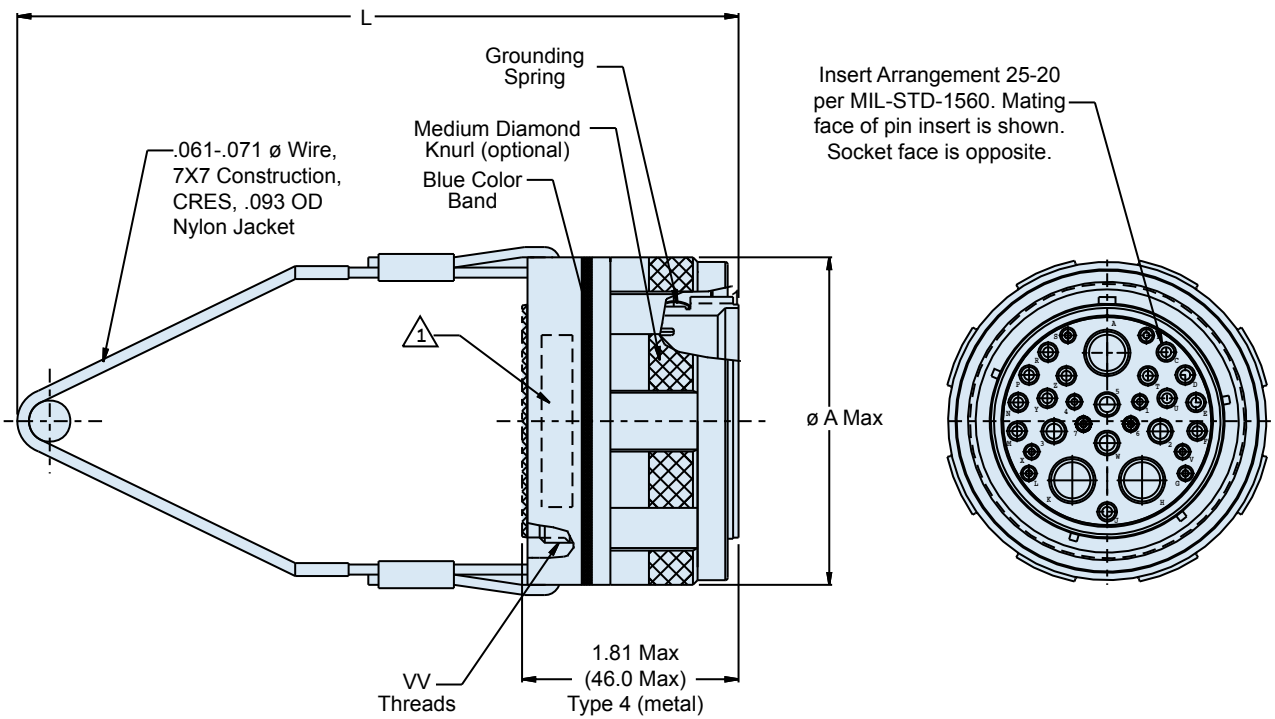

233-101-G6
Type 4 Lanyard Release Plug for MIL-STD-1760
and Other MIL-DTL-38999 Series III Type
Hybrid Signal, Power, Coax and Twinax Arrangements



TABLE I: CONNECTOR DIMENSIONS

SHELL SIZE	SHELL SIZE CODE	A MAX	W THREAD
09	A	1.00 (25.4)	M12 x1-6g-0.100R
11	B	1.110 (28.19)	M15 x1-6g-0.100R
13	C	1.972 (50.1)	M18x1-6g-0.100R
15	D	2.078 (52.8)	M22x1-6g-0.100R
17	E	2.204 (56.0)	M25x1-6g-0.100R
19	F	2.330 (59.2)	M28x1-6g-0.100R
21	G	2.472 (62.8)	M31x1-6g-0.100R
23	H	2.594 (65.9)	M34x1-6g-0.100R
25	J	2.704 (68.7)	M37x1-6g-0.100R

TABLE II: FINISH

Symbol	Finish
M	Al alloy, Electroless Nickel
Z1	CRES, Passivated
ZL	CRES, Electrodeposited Nickel
NF	Al alloy, Olive Drab Cadmium over Nickel

TABLE III: LANYARD LENGTH CODE

CODE	L ± .236 (±6)	CODE	L ± .236 (±6)	CODE	L ± .236 (±6)	CODE	L ± .236 (±6)
A	4.016(102)	G	7.007(178)	M	10.000(254)	U	13.031(331)
B	4.527(115)	H	7.519(191)	N	10.511(267)	V	14.015(356)
C	5.000(127)	I	7.992(203)	P	11.023(280)	W	15.000(381)
D	5.511(140)	J	8.503(216)	R	11.535(293)	X	16.023(407)
E	6.024(153)	K	9.015(229)	S	12.007(305)	Y	17.007(432)
F	6.535(166)	L	9.527(242)	T	12.519(318)	Z	18.031(458)

TABLE IV: SUPPLIED COMPONENTS

Contact Size	Contact Pin Part Number	Contact Socket Part Number	Sealing Plug Part Number	Insertion/Removal Tool Part Number
22D	M39029/58-360	M39029/56-348	M27488-22	M81969/14-01
20	M39029/58-363	M39029/56-351	M27488-20	M81969/14-10
16	M39029/58-364	M39029/56-352	M27488-16	M81969/14-03
12	M39029/58-365	M39029/56-353	M27488-12	M81969/14-04
12	M39029/102-558 Coax	M39029/103-559 Coax	M27488-12	M81969/14-04
8	M39029/60-367 Coax	M39029/59-366 Coax	M27488-8	M81969/14-06
8	M39029/90-529 Twinax	M39029/91-530 Twinax	M27488-8	M81969/14-06

APPLICATION NOTES

- Assembly to be identified with Glenair's name and part number.
- Material/finishes:
 Shell, coupling sleeve, lanyard ring—Aluminum alloy or CRES per Table I
 Retaining clips—Beryllium copper/gold plated
 Insulators—High grade rigid dielectric/NA
 Wave spring, retaining rings—Cres
 Grounding Spring—Beryllium copper/electroless nickel
 Seals—fluorosilicone/NA
- This connector mates with D38999/20 and /24,
- Dimensions in parenthesis are metric and for reference.
- Blue color band indicates rear release retention system.
- Connectors to be supplied with contacts, insertion/removal tools and sealing plugs. Quantity of contacts includes spares (see Table IV).



2570-1269
ARINC 828
 MIL-DTL-38999 Series III Type
 Quadrax Plug/Receptacle for EFB Standard

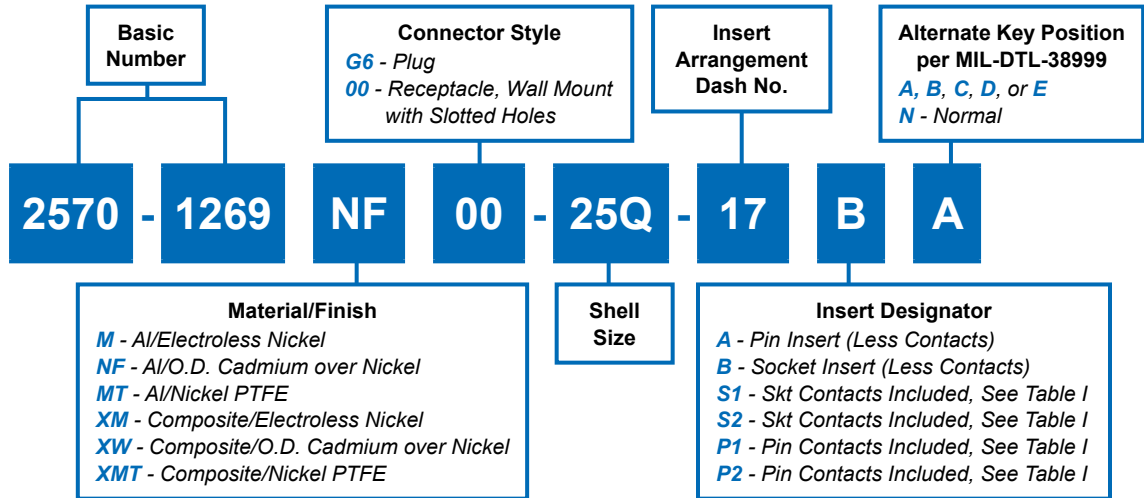
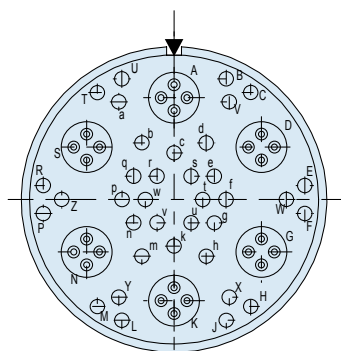
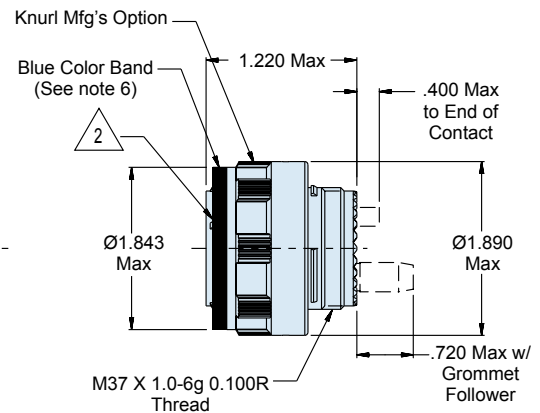
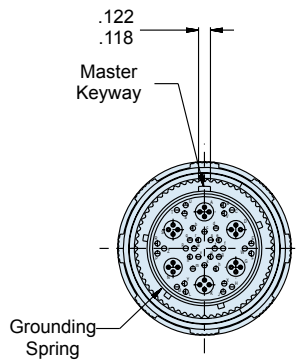

FIGURE 1: INSERT ARRANGEMENTS



Arrangement 25Q-17
 36 #22 Contacts
 6 #8 Quadrax Contacts
 (J2, J3, J4)



G6 - Plug

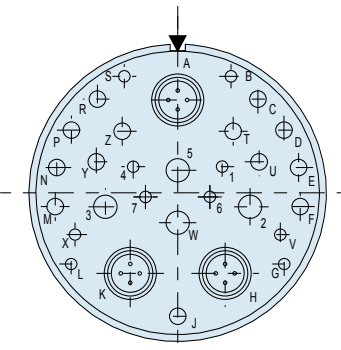

Arrangement 25Q-20
 (IAW prEN 3645-001)
 10 #20 Contacts
 13 #16 Contacts
 4 #12 Contacts
 3 #8 Quadrax Contacts
 (J1)

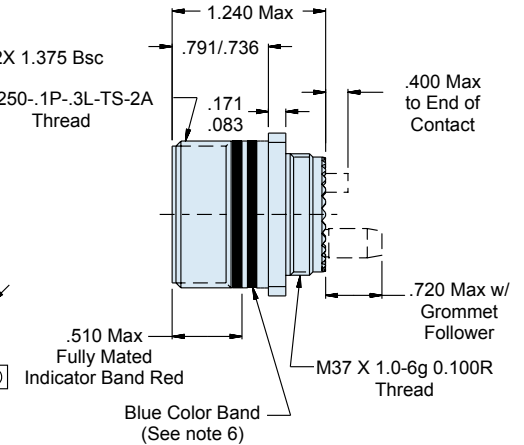
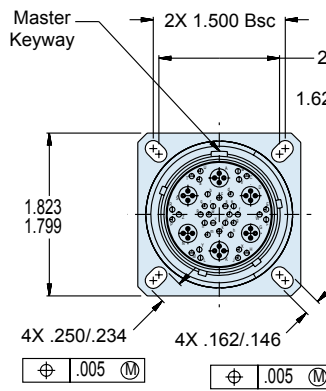

00-Wall Mount Receptacle
 With Slotted Holes

2570-1269
ARINC 828
MIL-DTL-38999 Series III Type
Quadrax Plug/Receptacle for EFB Standard



Table I: Cross-Reference to ARINC 828 Connectors (Wall Mount Receptacle)

ARINC 828 (Receptacle)	Glenair Conn P/N (See Notes 3 and 4)	Quadrax Contact Socket P/N	Qty	Reference Cable Accommodated
J1	2570-1269M00-25Q-20BA	Not Supplied (To Be Ordered Separately. See Note 5)		
	2570-1269M00-25Q-20S1A	854-002-02F	3	PIC E51424;TENSOLITE NF24Q100; BMS 13-72T03C04G024*; ECS 422404*
	2570-1269M00-25Q-20S2A	854-002-04F	3	PIC E50424*; ABS 1503KD24*
J2	2570-1269M00-25Q-17BA	Not Supplied (To Be Ordered Separately. See Note 5)		
	2570-1269M00-25Q-17S1A	854-002-02F	6	PIC E51424;TENSOLITE NF24Q100; BMS 13-72T03C04G024*; ECS 422404*
	2570-1269M00-25Q-17S2A	854-002-04F	6	PIC E50424*; ABS 1503KD24*
J3	2570-1269M00-25Q-17BB	Not Supplied (To Be Ordered Separately. See Note 5)		
	2570-1269M00-25Q-17S1B	854-002-02F	6	PIC E51424;TENSOLITE NF24Q100; BMS 13-72T03C04G024*; ECS 422404*
	2570-1269M00-25Q-17S2B	854-002-04F	6	PIC E50424*; ABS 1503KD24*
J4	2570-1269M00-25Q-17BC	Not Supplied (To Be Ordered Separately. See Note 5)		
	2570-1269M00-25Q-17S1C	854-002-02F	6	PIC E51424;TENSOLITE NF24Q100; BMS 13-72T03C04G024*; ECS 422404*
	2570-1269M00-25Q-17S2C	854-002-04F	6	PIC E50424*; ABS 1503KD24*

Table II: Quadrax Contact Pin P/N for Plug Connector

	Quadrax Contact Pin P/N	Reference Cable Accommodated
P1	854-001-02F	PIC E51424;TENSOLITE NF24Q100; BMS 13-72T03C04G024*; ECS 422404*
P2	854-001-04F	PIC E50424*; ABS 1503KD24*

Recommended Panel Mounting Holes (Receptacle)

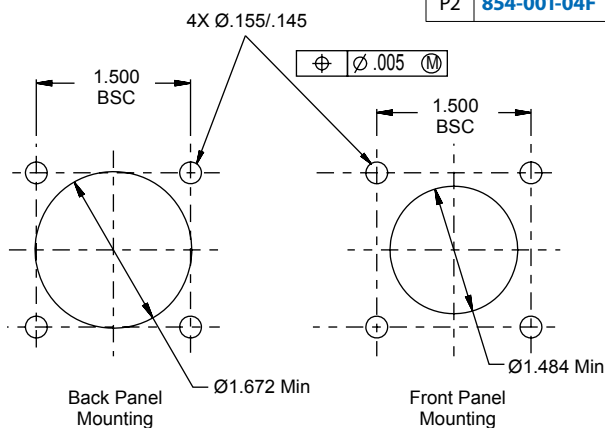

Table III: Signal/Power Contact P/N (to be supplied w/ "P" or "S")

Pin/Socket	Contact Size	Contact P/N
Pin	22	M39029/58-360
	20	M39029/58-363
	16	M39029/58-364
	12	M39029/58-365
Socket	22	M39029/56-348
	20	M39029/56-351
	16	M39029/56-352
	12	M39029/56-353

APPLICATION NOTES

- Material/Finishes:
Receptacle, Barrel, Coupling Nut - See P/N Development
Insulators - High Grade Rigid Dielectric
Seals - Fluorosilicone
Grounding Spring - BeCu Alloy
Quadrax Contacts -
Pin - See 854-001-XX (XX Denotes Cable Type, See Table II)
Socket - See 854-002-XX (XX Denotes Cable Type, See Table I)
Grommet Follower - 687-754-8-X
Signal/Power Contacts - When insert designator is P* or S*, the Signal/Power contacts in Table III will be shipped with connector, as required, along with Quadrax contacts.
- Insert arrangement is in accordance with MIL-STD-1560 and Figure 1
- Common EFB connector material/finish IAW ARINC 828 is Al/ Electroless Nickel, code "M". Other material/finishes are also available, see P/N development for ordering.
- All "J*" connectors, as defined in ARINC 828, are receptacles and their contacts are sockets. The mating plug connectors with pin contacts are not defined in the standard, and can be ordered as shown in P/N development.
- Glenair connector is designed to accept Glenair Quadrax contacts only.
- Blue color band indicates rear release system.



Glenair Twinax and Quadrax MIL-DTL-38999 Type Connectors

SECTION E TABLE OF CONTENTS

GLENAIR MIL-DTL-38999 TYPE TWINAX AND QUADRAX CONNECTORS:

MIL-DTL-38999 Type Twinax and Quadrax Connectors Product Features.....	E-1
247-410 Metal or Composite Ground Plane Twinax Connector, 8 Ga.....	E-2
257-411 Metal or Composite Twinax Receptacle Connector, Jam Nut Mount, 8 Ga.....	E-4
257-414 (H) Metal or Composite Twinax Receptacle Connector, Box Mount, Standard Holes.....	E-6
257-414 (S7) Metal or Composite Twinax Receptacle Connector, Box Mount, Slotted Holes.....	E-7
257-414 (T7) Metal or Composite Twinax Receptacle Connector, Box Mount, Tapped Holes.....	E-8
247-414 Metal or Composite Twinax Receptacle Connector Dimensions, Finish & Ground Plane..	E-9
247-414 Metal or Composite Twinax Receptacle Connector Dimensions and Cut-Outs.....	E-10
257-410, 257-411 and 257-414 Twinax Connector Insert Arrangements.....	E-11
257-455 Box Mount QUadrax Connector with PC Tails.....	E-12
257-459 Wall Mount Plug Quadrax Connector.....	E-14
257-606 (00) Wall Mount Quadrax Receptacle Connector with Slotted Holes.....	E-16
257-606 (G6) Quadrax Plug Connector.....	E-17
257-606 (07) Jam Nut Mount Receptacle Connector.....	E-18
257-606 Quadrax Connector Dimensions, Finish and Ground Plane.....	E-19
257-606 Quadrax Connector Dimensions and Cut-Outs.....	E-20
257-606 Quadrax Connector Insert Arrangements.....	E-21
257-616 Twinax and Quadrax PC Tail Contacts.....	E-22
854-001 and 854-002 Crimp Quadrax Pin and Socket Contacts.....	E-23

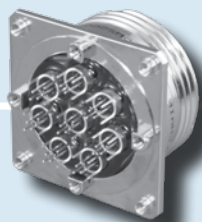

MIL-DTL-38999 Twinax and Quadrax Connector for Reliable High-Speed Applications

Product Applications

Glenair is recognized as trusted supplier of harsh environment electrical connectors built to the MIL-DTL-38999 standard. Both quadrax and twinax appear to have unique but equally beneficial qualities. The quadrax connector has four pins connected to a single cable, providing two-way Ethernet data communications. The twinax connector with two pins, provides one-way communication. Two twinax connectors and two wires are required for two-way communications which adds up to about 50% more weight than a quadrax connection. Twinax connectors have proven to be highly reliable and easy to maintain. Quadrax connectors are more difficult to maintain in the field and are yet to be thoroughly proven for reliability. Depending on the application, the end user will prefer one or the other (for example,

Airbus prefers Quadrax while Boeing prefers twinax) which is why Glenair offers both.

Available Insert Arrangements

Based on industry-standard specifications, Glenair's MIL-DTL-38999 derivative environmental class connector systems are supplied with insert arrangements IAW MIL-STD-1560, or appropriate sub-sets depending on connector series. Consult factory for available insert arrangements.

Errata

Catalog contents—including part numbers, materials and dimensions—are accurate to the best of our ability when we go to print. When errors or mistakes are brought to our attention, corrected content is posted immediately to www.glenair.com.

Same-Day Delivery on Many Common Shell Styles and Layouts

Selected Range of D38999 Series I thru III Pin and Socket Insert Arrangements—Consult Factory for Availability

Lightweight, Corrosion-Free Composite Versions

Special Lanyard-Release Versions

All Standard Material Options, Including Stainless Steel

Jam Nut, Solder Mount, Wall Mount and Box Mount Options

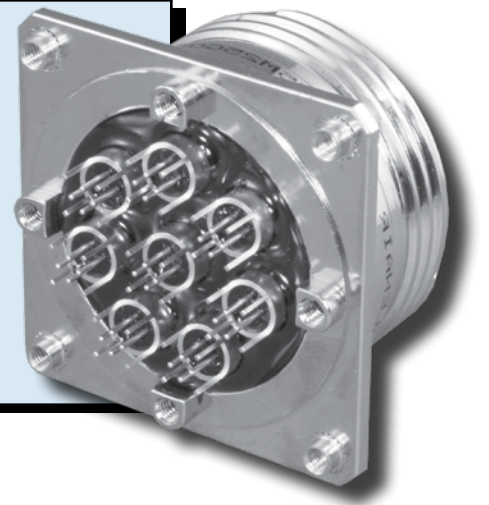

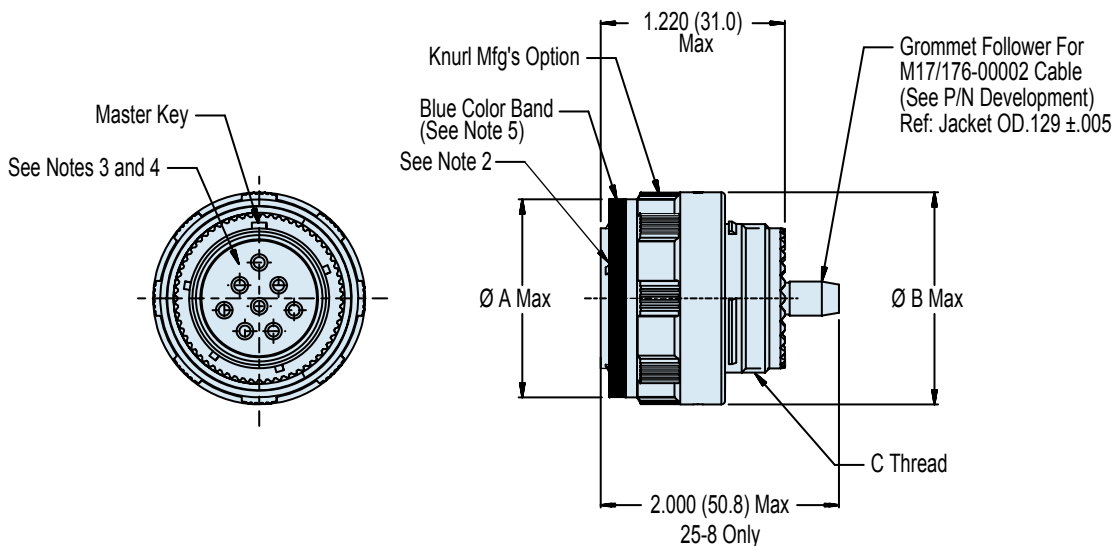
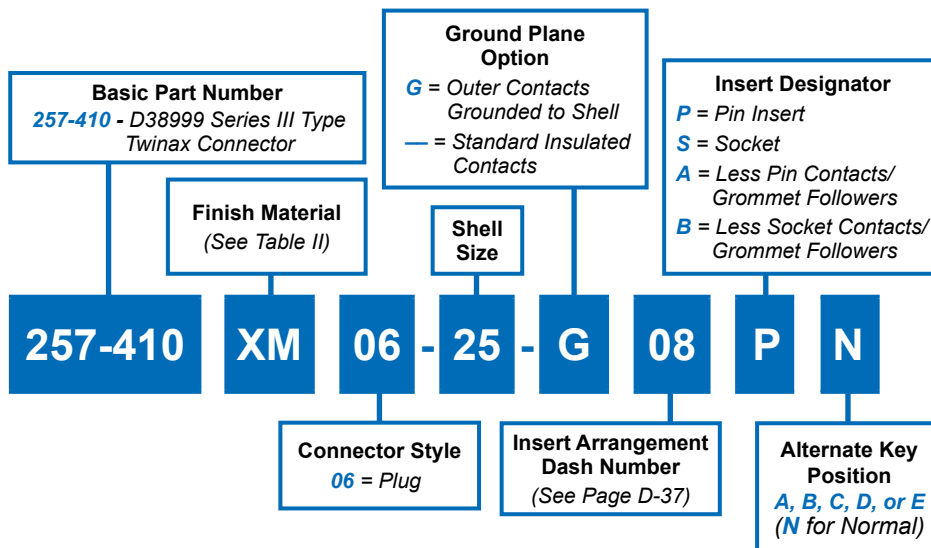

APPLICATION NOTES

- Material/Finishes:
Plug barrel/Coupling nut - See Table II.
(Composite coupling is unplated).
Insulator - Aluminum alloy/Conductive plate
or high-grade thermoplastic.
Contact retainer clips - HT BeCu/Conductive plate.
Seals - Fluorosilicone/N.A.
- Assembly to be identified with Glenair's name, partnumber
and date code, space permitting.
- Insert arrangements are in accordance with MIL-STD-1560
(See page D-37).
- Insert arrangement shown is for reference only.
- Blue color band indicates rear release retention system.
- Ground plane performance: per Table II, between outer
contact and plug barrel (see part number development).
- For P and S, plug is supplied with contacts P/N M39029/90-
529 (Pin) or M39029/91-530 (Socket) and Grommet Follower
P/N 687-643-8-1 (No spares/sealing plugs provided).
- Metric dimensions (mm) are in parentheses.

257-410
Metal or Composite Ground Plane Twinax Connector
8GA • MIL-DTL-38999 Series III Type



TABLE I: SHELL SIZE

Shell Size	A Dia Max	B Dia Max	C Thread
09	.811 (20.6)	.858 (21.8)	M12 x 1.0-6g 0.100R
21	1.594 (40.5)	1.642 (41.7)	M31 x 1.0-6g 0.100R
23	1.720 (43.7)	1.768 (44.9)	M34 x 1.0-6g 0.100R
25	1.843 (46.8)	1.890 (48.0)	M37 x 1.0-6g 0.100R

TABLE II: MATERIAL/FINISH and GROUND PLANE

Sym	Material	Finish	Ground Plane
M	Aluminum	Electroless Nickel	1 mV
NF		Cadmium O.D. Over Electroless Nickel	2.5 mV
XM	Composite	Electroless Nickel	3.0 mV
XW		Cadmium O.D. over Electroless Nickel	3.0 mV

Consult Factory for Additional Plating Options



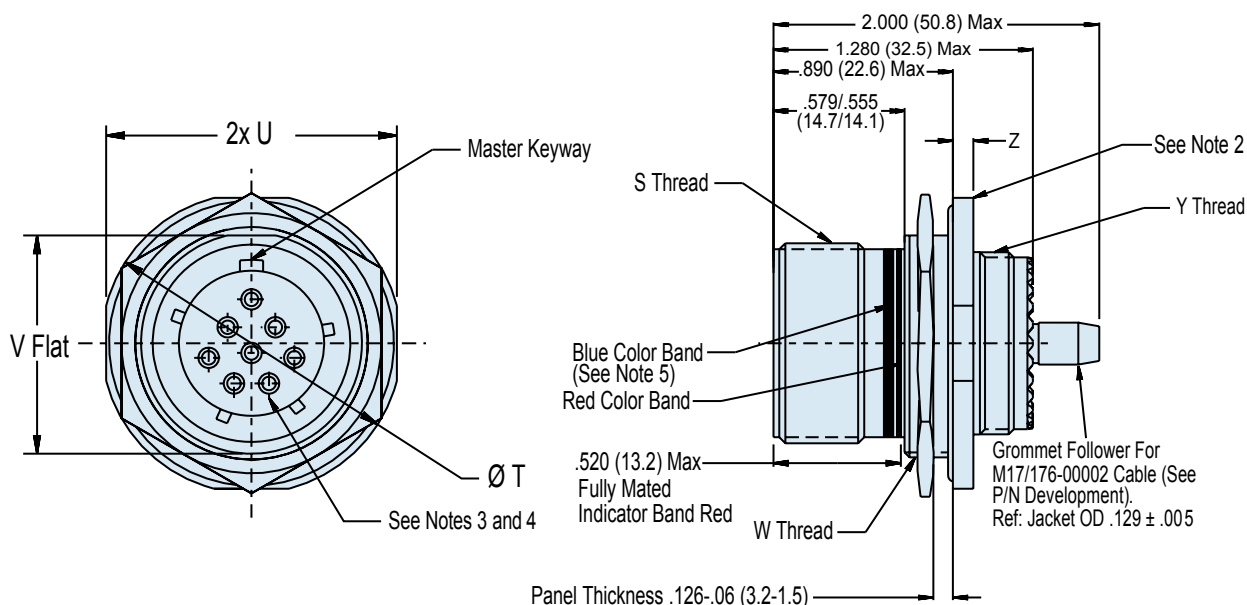
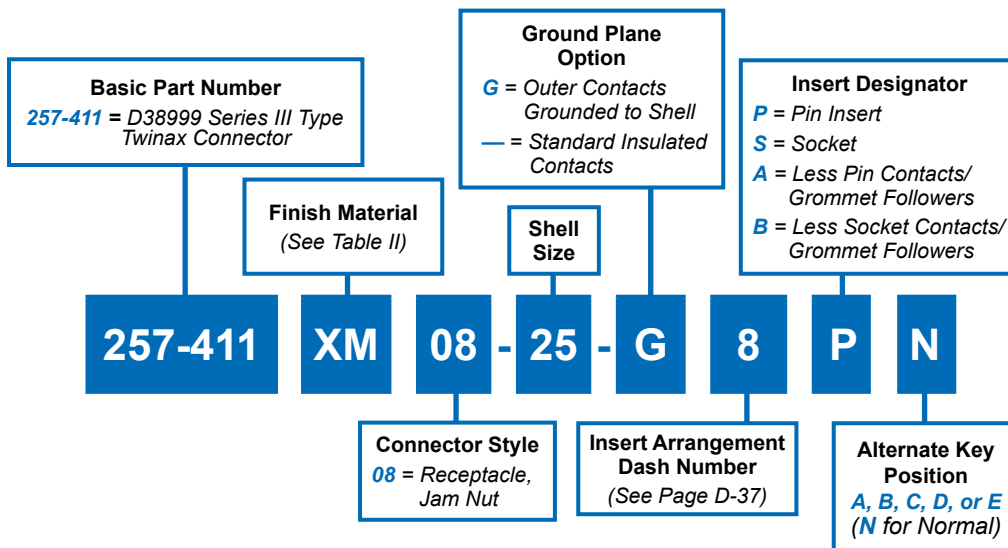

APPLICATION NOTES

- Material/Finishes:
 Receptacle and Jam Nut - See Table II.
 (Composite coupling is unplated).
 Insulators - Aluminum alloy/Conductive plate
 or high-grade thermoplastic.
 Contact retainer clips - HT BeCu/Conductive plate.
 Seals - Fluorosilicone/N.A.
- Assembly to be identified with Glenair's name, partnumber
 and date code, space permitting.
- Insert arrangements are in accordance with MIL-STD-1560
 (See page D-37).
- Insert arrangement shown is for reference only.
- Blue color band indicates rear release retention system.
- Ground plane performance: per Table II, between outer
 contact and plug barrel (see part number development).
- For P and S, receptacle is supplied with contacts P/N
 M39029/90-529 (Pin) or M39029/91-530 (Socket) and
 Grommet Follower P/N 687-643-8-1 (No spares/sealing plugs
 provided).
- Metric dimensions (mm) are in parentheses.

257-411
Twinax Receptacle Connector
 Jam Nut Mount • Metal or Composite
 Ground Plane • 8GA • MIL-DTL-38999 Series III Type



TABLE I: MATERIAL/FINISH and GROUND PLANE			
Sym	Material	Finish	Ground Plane
M	Aluminum	Electroless Nickel	1 mV
NF		Cadmium O.D. Over Electroless Nickel	2.5 mV
XM	Composite	Electroless Nickel	3.0 mV
XW		Cadmium O.D. over Electroless Nickel	3.0 mV

Consult Factory for Additional Plating Options

TABLE II: JAM NUT MOUNT							
Shell Size	S Thread	T Dia	U	V	W Thread	Y Thread	Z
9	.6250-.1P-.3L-TS2A	1.201 (30.5) 1.177 (44.9)	1.079 (27.4) 1.047 (26.6)	.655 (16.6) .645 (16.4)	M17 x 1.0-6g 0.100R	M12 x 1.0-6g 0.100R	.122 (3.1) .083 (2.1)
21	1.3750-.1P-.3L-TS-2A	2.075 (52.7) 2.051 (52.1)	1.953 (49.6) 1.921 (48.8)	1.441 (36.6) 1.431 (36.3)	M38 x 1.0-6g 0.100R	M31 x 1.0-6g 0.100R	
23	1.5000-.1P-.3L-TS-2A	2.201 (55.9) 2.177 (55.3)	2.079 (52.8) 2.047 (52.0)	1.566 (39.8) 1.556 (39.5)	M41 x 1.0-6g 0.100R	M34 x 1.0-6g 0.100R	.153 (3.9) .114 (2.9)
25	1.6250-.1P-.3L-TS-2A	2.323 (59.0) 2.299 (58.4)	2.205 (56.0) 2.173 (55.2)	1.691 (43.0) 1.681 (42.7)	M44 x 1.0-6g 0.100R	M37 x 1.0-6g 0.100R	

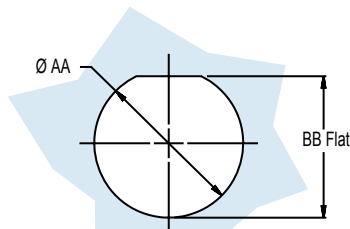

RECOMMENDED PANEL CUT OUT
 (See Table III)

TABLE III: CUT-OUT		
Shell Size	AA Dia Max	BB
09	.710 (18.0)	.670 (17.0)
	.700 (17.8)	.660 (16.8)
21	1.520 (38.6)	1.460 (37.1)
	1.510 (38.4)	1.450 (36.8)
23	1.645 (41.8)	1.585 (40.3)
	1.635 (41.5)	1.575 (40.0)
25	1.770 (45.0)	1.710 (43.4)
	1.760 (44.7)	1.700 (43.2)





257-414 (H7) Metal or Composite Twinax Receptacle Connector Box Mount with Standard Holes Ground Plane • 8GA • MIL-DTL-38999 Series III Type

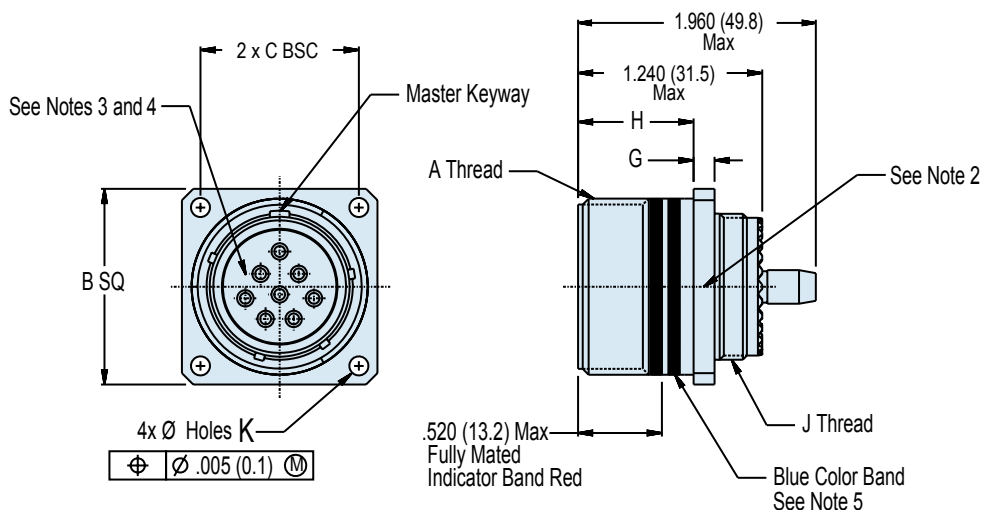
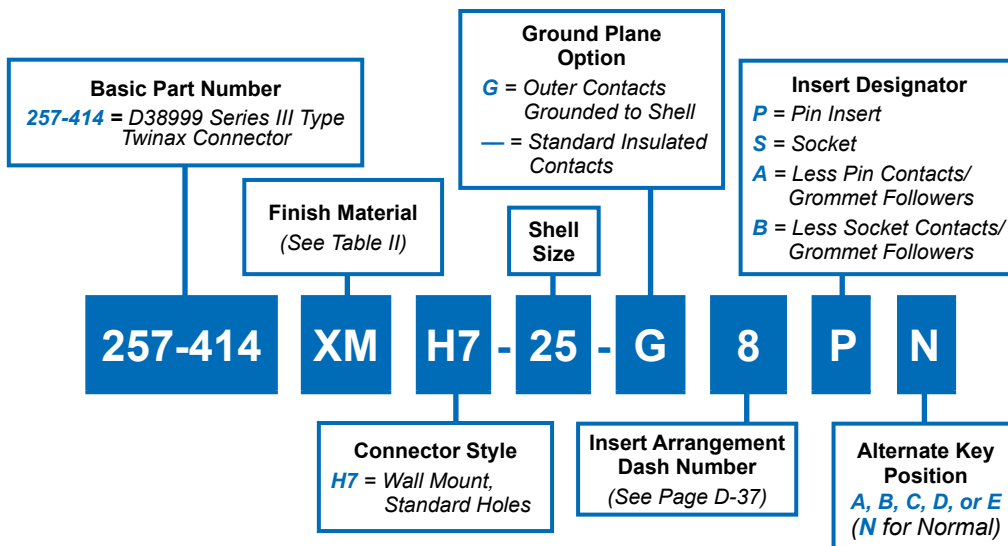

APPLICATION NOTES

- Material/Finishes:
Receptacle and Jam Nut - See Table II. (Composite coupling is unplated).
Insulators - Aluminum alloy/Conductive plate or high-grade thermoplastic.
Contact retainer clips - HT BeCu/Conductive plate.
Seals - Fluorosilicone/N.A.
- Assembly to be identified with Glenair's name, partnumber and date code, space permitting.
- Insert arrangements are in accordance with MIL-STD-1560 (See page D-37).
- Insert arrangement shown is for reference only.
- Blue color band indicates rear release retention system.
- Ground plane performance: per Table II, between outer contact and plug barrel (see part number development).
- For P and S, receptacle is supplied with contacts P/N M39029/90-529 (Pin) or M39029/91-530 (Socket) and Grommet Follower P/N 687-643-8-1 (No spares/sealing plugs provided).
- Metric dimensions (mm) are in parentheses.

257-414 (S7)
Metal or Composite Twinax Receptacle Connector
Box Mount with Slotted Holes
Ground Plane • 8GA • MIL-DTL-38999 Series III Type

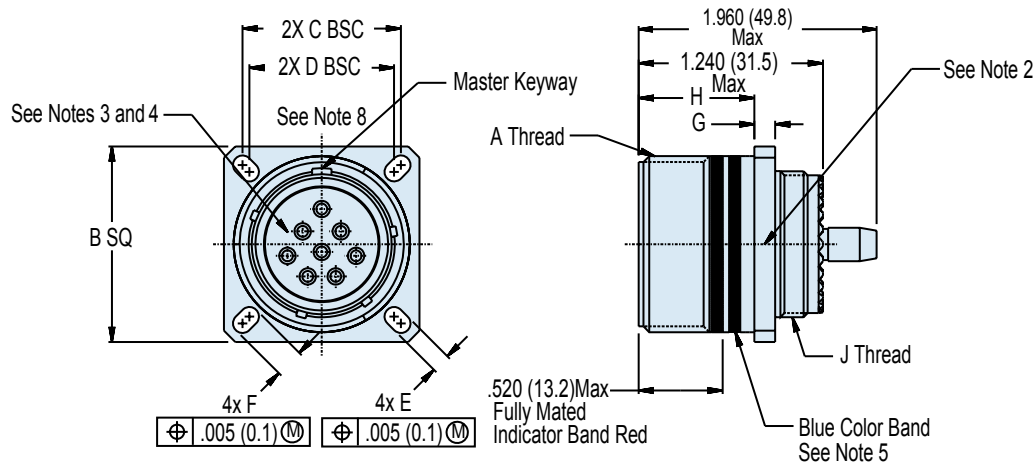
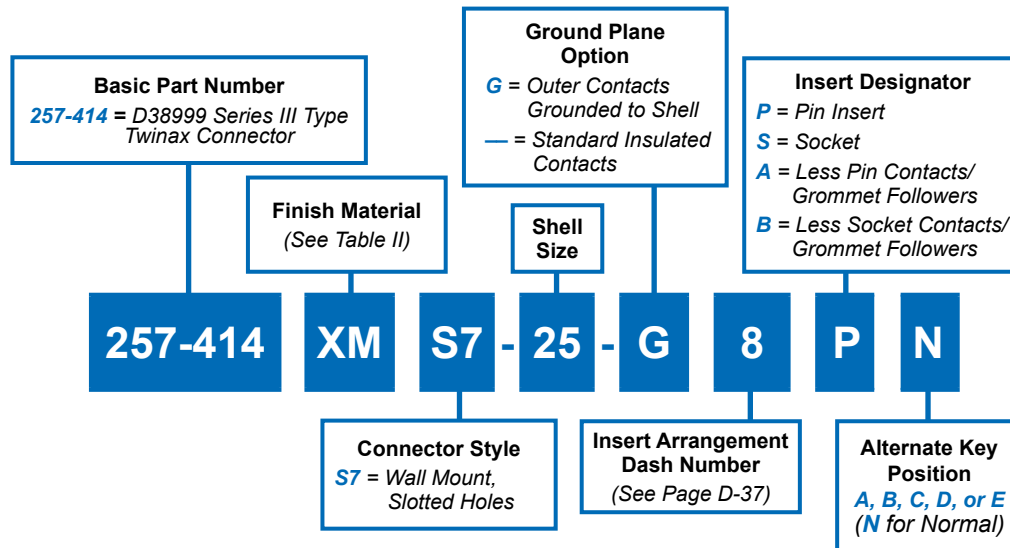

APPLICATION NOTES

- Material/Finishes:
 Receptacle and Jam Nut - See Table II. (Composite coupling is unplated).
 Insulators - Aluminum alloy/Conductive plate or high-grade thermoplastic.
 Contact retainer clips - HT BeCu/Conductive plate.
 Seals - Fluorosilicone/N.A.
- Assembly to be identified with Glenair's name, partnumber and date code, space permitting.
- Insert arrangements are in accordance with MIL-STD-1560 (See page D-37).
- Insert arrangement shown is for reference only.
- Blue color band indicates rear release retention system.
- Ground plane performance: per Table II, between outer contact and plug barrel (see part number development).
- For P and S, receptacle is supplied with contacts P/N M39029/90-529 (Pin) or M39029/91-530 (Socket) and Grommet Follower P/N 687-643-8-1 (No spares/sealing plugs provided).
- Metric dimensions (mm) are in parentheses.

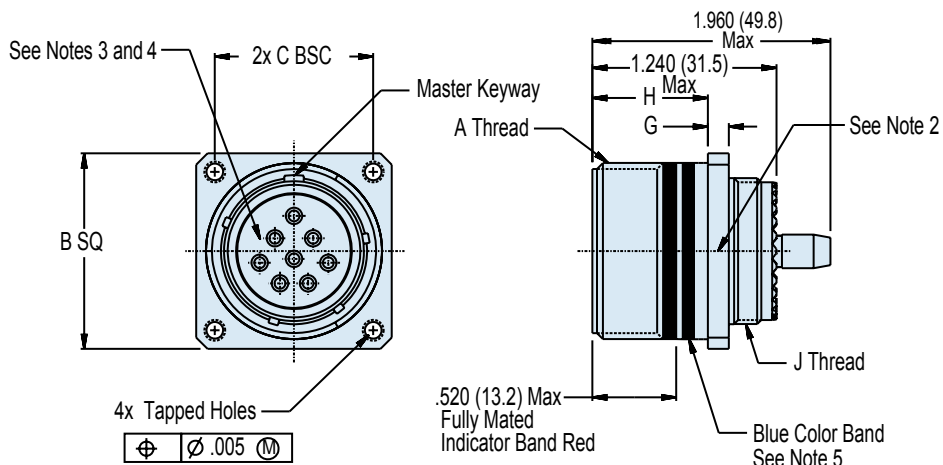
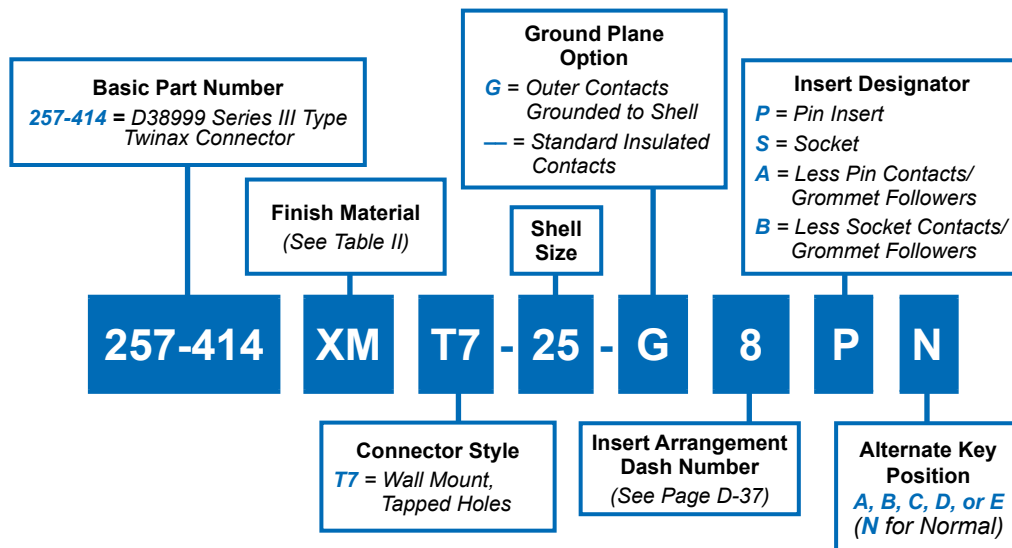

APPLICATION NOTES

- Material/Finishes:
 Receptacle and Jam Nut - See Table II. (Composite coupling is unplated).
 Insulators - Aluminum alloy/Conductive plate or high-grade thermoplastic.
 Contact retainer clips - HT BeCu/Conductive plate.
 Seals - Fluorosilicone/N.A.
- Assembly to be identified with Glenair's name, partnumber and date code, space permitting.
- Insert arrangements are in accordance with MIL-STD-1560 (See page D-37).
- Insert arrangement shown is for reference only.
- Blue color band indicates rear release retention system.
- Ground plane performance: per Table II, between outer contact and plug barrel (see part number development).
- For P and S, receptacle is supplied with contacts P/N M39029/90-529 (Pin) or M39029/91-530 (Socket) and Grommet Follower P/N 687-643-8-1 (No spares/sealing plugs provided).
- Metric dimensions (mm) are in parentheses.

257-414
Metal or Composite Twinax Receptacle Connector
Dimensions, Finish, Material and Ground Plane
8GA • MIL-DTL-38999 Series III Type



TABLE I: SHELL SIZE AND DIMENSIONS (Continued on following page)

Shell Size	A Thread	B SQ	C BSC	D BSC (See Note 8)	E	F	G	H
9	.6250-.1P-.3L-TS-2A	.949 (24.1)	.719 (18.3)	.626 (15.9)	.136 (3.45)	.224 (5.7)	.144 (3.7)	.823 (20.9)
		.925 (23.5)				.208 (5.3)		
21	1.3750-.1P-.3L-TS-2A	1.575 (40.0)	1.156 (29.4)	1.125 (28.6)	.120 (3.0)	.202 (5.1)		
		1.551 (39.4)				.186 (4.7)		
23	1.5000-.1P-.3L-TS-2A	1.701 (43.2)	1.375 (34.9)	1.250 (31.8)	.162 (4.1)	.250 (6.4)	.171 (4.3)	.791 (20.1)
		1.677 (42.6)				.234 (5.9)		
25	1.6250-.1P-.3L-TS-2A	1.823 (46.3)	1.500 (38.1)	1.375 (34.9)	.146 (3.7)			
		1.799 (45.7)						

TABLE II: MATERIAL/FINISH and GROUND PLANE

Sym	Material	Finish	Ground Plane
M	Aluminum	Electroless Nickel	1 mV
NF		Cadmium O.D. Over Electroless Nickel	2.5 mV
XM	Composite	Electroless Nickel	3.0 mV
XW		Cadmium O.D. over Electroless Nickel	3.0 mV

Consult Factory for Additional Plating Options



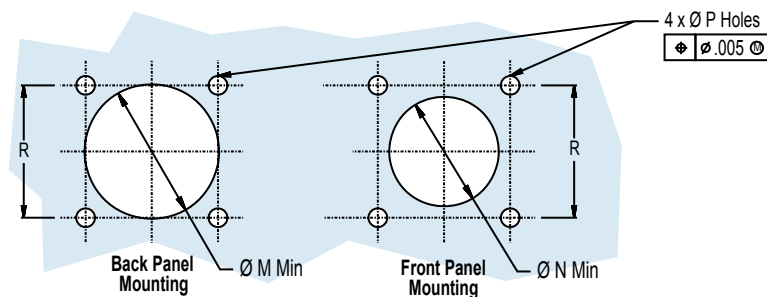

Recommended Mounting For Wall Mount Receptacles, See Table II

TABLE I: SHELL SIZE AND CUT-OUT DIMENSIONS (Table continued from preceding page)

Shell Size	J Thread	K Dia	L Tapped Holes	M Dia Min	N Dia Min	P Holes	R BSC
9	M12 x 1.0-6g 0.100R	.136 (3.5) .120 (3.0)	.112-40 UNC-2B	.656 (16.7)	.516 (13.1)	.133 (8.4) .123 (3.1)	.719 (18.3)
21	M31 x 1.0-6g 0.100R			1.422 (36.1)	1.266 (32.2)		1.250 (31.8)
23	M34 x 1.0-6g 0.100R	.162 (4.1) .146 (3.7)	.138-32 UNC-2B	1.547 (39.3)	1.375 (34.9)	.159 (4.0) .149 (3.8)	1.375 (34.9)
25	M37 x 1.0-6g 0.100R			1.672 (42.5)	1.484 (37.7)	.155 (3.9) .145 (3.7)	1.500 (38.1)

MIL-DTL-38999 Series III Type
 257-410, 257-411 and 257-414 Twinax Connectors
 Insert Arrangements (IAW MIL-STD-1560)

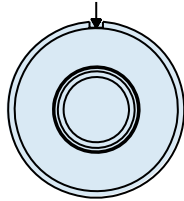

ARRANGEMENT 09-05

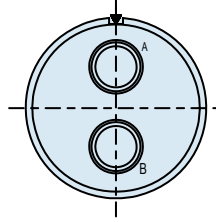

ARRANGEMENT 17-75

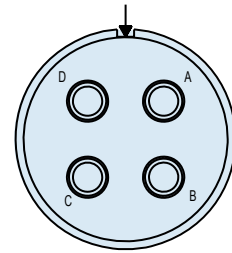

ARRANGEMENT 21-75

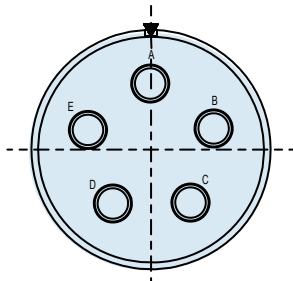

ARRANGEMENT 23-05

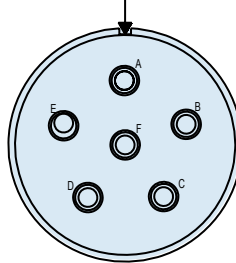

ARRANGEMENT 23-06

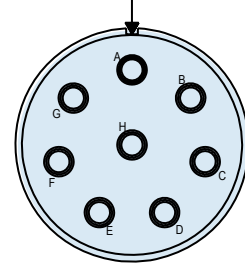

ARRANGEMENT 25-08

Mating Face of Pin Insert Shown



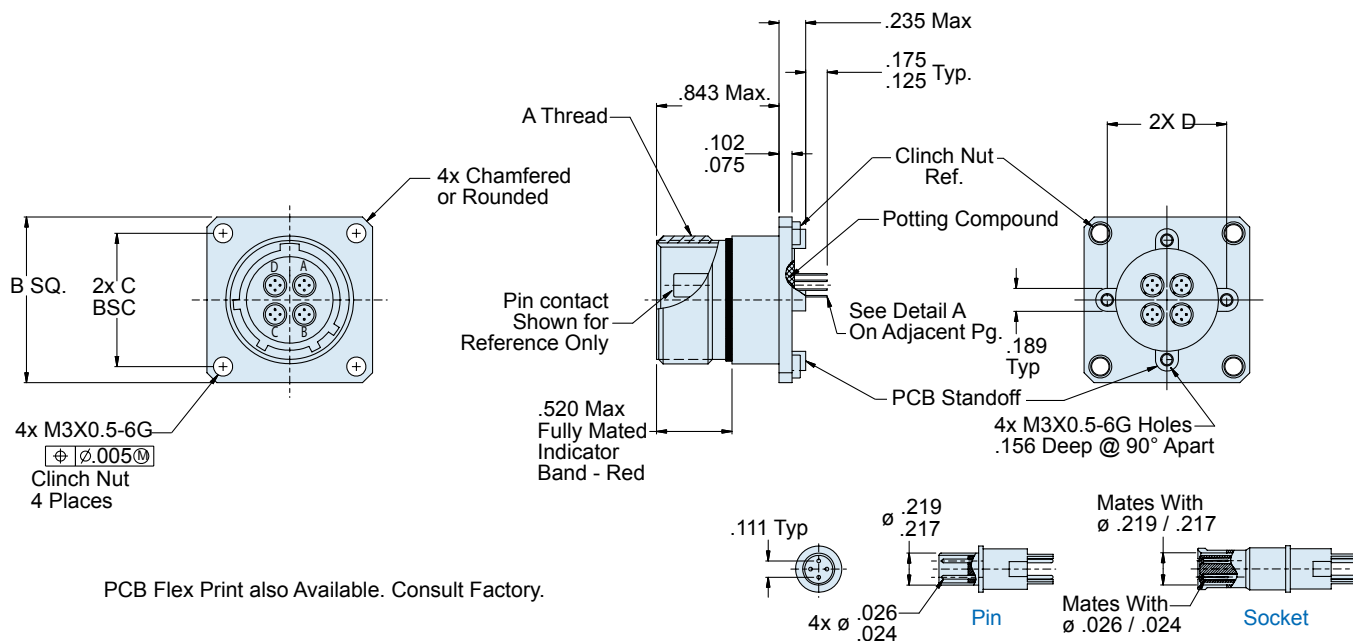
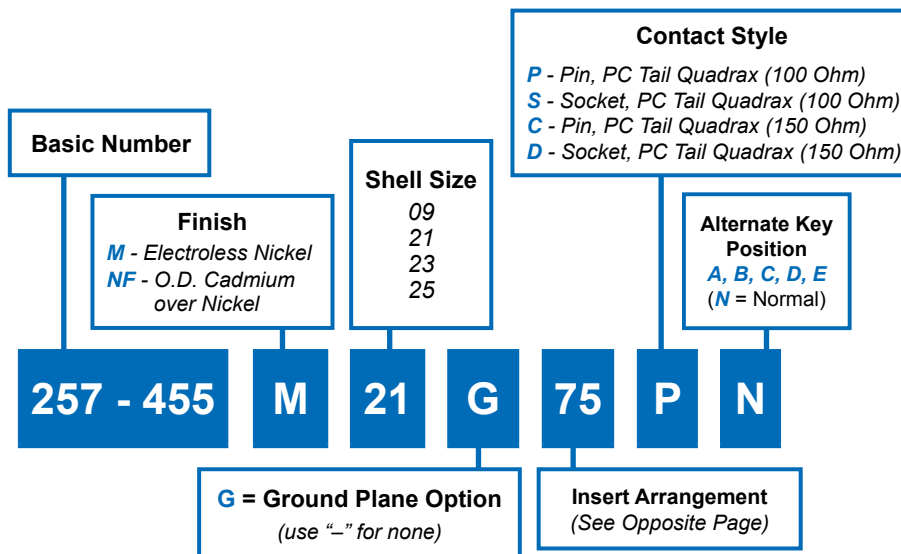

APPLICATION NOTES

1. Assembly identified with Glenair's, part number and date code
2. Insert arrangements IAW MIL-STD-1560 and Figure I
3. Glenair 257-455 receptacle connector is designed to mate with any QPL manufacturers MIL-C-38999 series III plug connector having the same insert arrangement, polarization and the same quadrax interface dimensions shown.
4. PC contacts supplied with connector (installed) and are not sold separately.
5. Material/finish:
 Shell assembly, jam nut, lock ring—Al alloy/see Table II
 Contacts—copper alloy/gold plate
 Bayonet pins—CRES/passivate
 O-rings, interfacial & peripheral seals—silicone/N.A.
 Insulators—high grade rigid dielectric/ N.A.
6. Metric Dimensions (mm) are indicated in parentheses

257-455
Box Mount Quadrax Connector
 With PC Tails • MIL-DTL-38999 Series III Type



Twinax and
 Quadrax
 Connectors

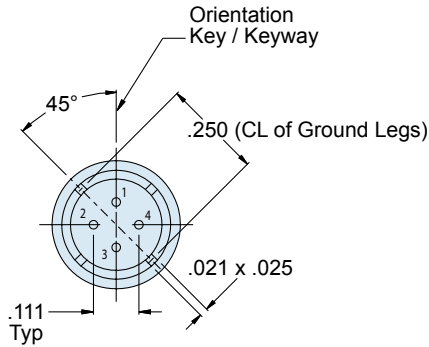

Rear View of Differential Quadrax

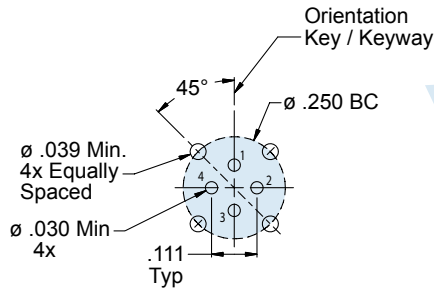

Recommended PCB Layout

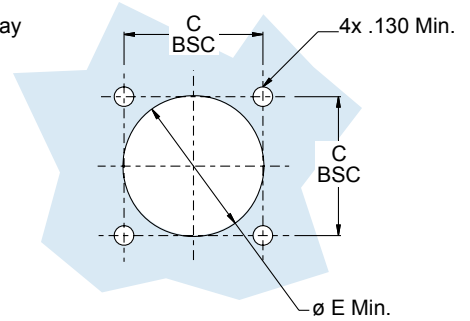

Back Panel Mounting

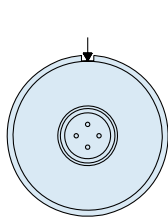

Arrangement 09-5

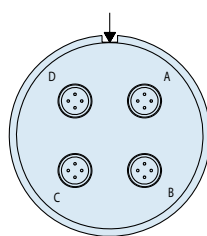

Arrangement 21-75

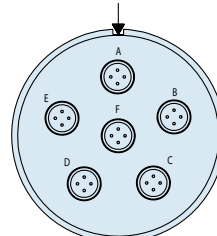

Arrangement 23-06

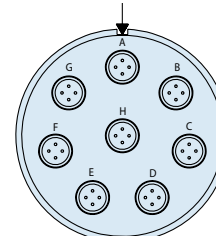

Arrangement 25-08

See Quadrax Contact Information on D-24

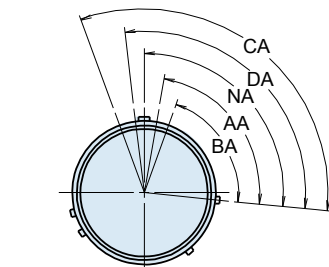
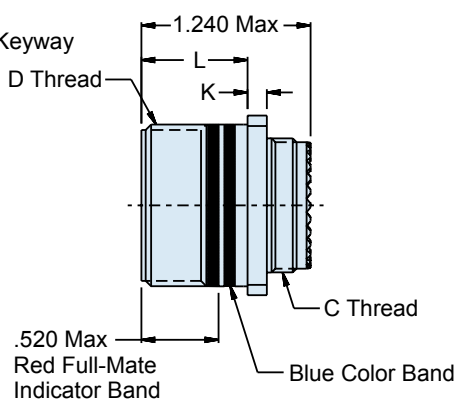
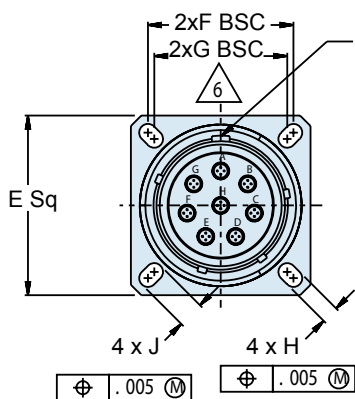
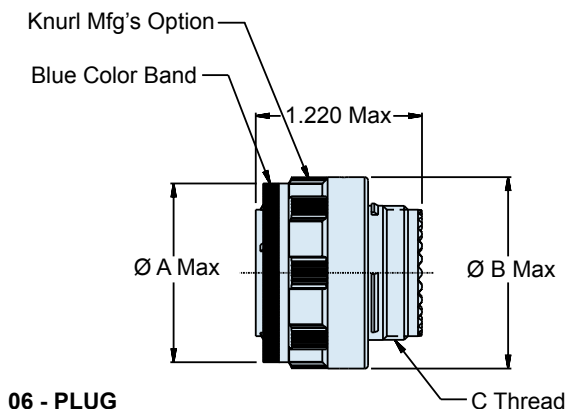
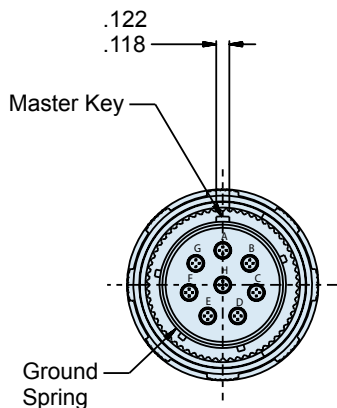
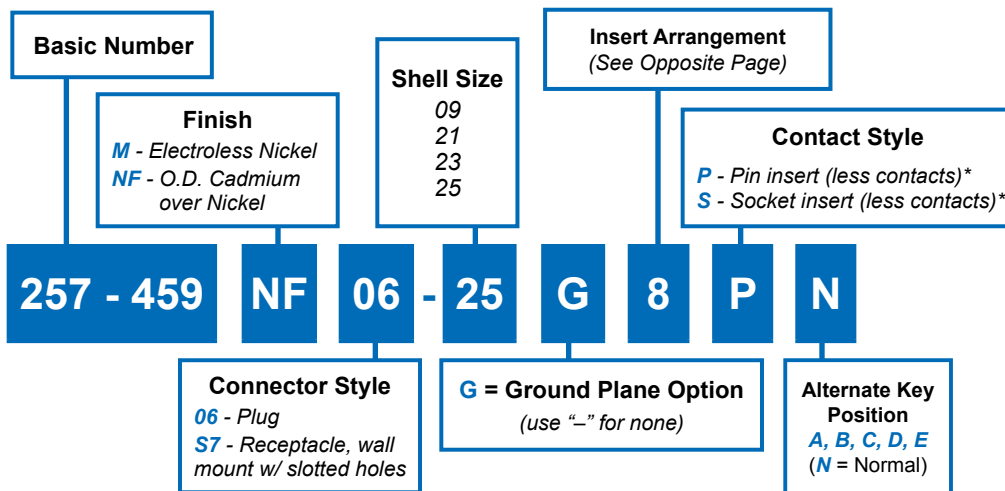

Figure 1
 Master Keyway Position
 Face View Shown
 Insert Arrangement Does
 Not Rotate With Master Keyway

TABLE I					
Shell Size	A Thread	B Sq.	C Bsc.	D Bsc.	ø E Min.
09	.6250-.1P-.3L-TS-2A	1.031 1.007	.719	.594	.656
21	1.3750-.1P-.3L-TS-2A	1.575 1.545	1.250	1.221	1.421
23	1.5000-.1P-.3L-TS-2A	1.701 1.677	1.375	1.360	1.546
25	1.6250-.1P-.3L-TS-2A	1.823 1.799	1.500	1.475	1.672





257-459 (06) or (S7)
 Plug or Wall Mount Receptacle Quadrax Connector
 MIL-DTL-38999 Series III Type

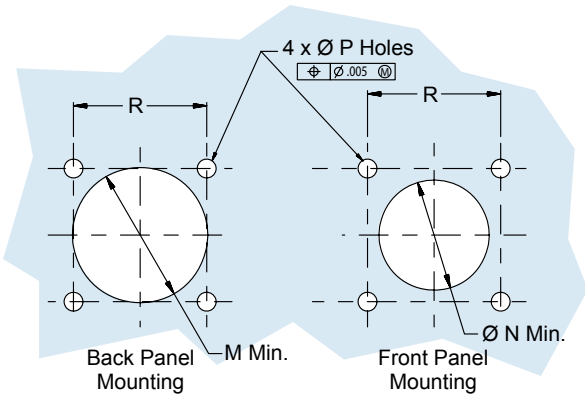

Shell Size Code	Shell Size	ø A Max.	ø B Max.	C Thread
A	09	.732	.858	M12 x 1.0-g 0.100R
G	21	1.508	1.642	M31 x 1.0-g 0.100R
H	23	1.626	1.768	M34 x 1.0-g 0.100R
J	25	1.752	1.890	M37 x 1.0-g 0.100R

Shell Size Code	Shell Size	D Thread	E Sq.	F BSC	G BSC	H	J	K	L
A	09	.6250-.1P-.3L-TS-2A	.949 .925	.719	.626	.136 .120	.224 .208	.144 .083	.823 .768
G	21	1.3750-.1P-.3L-TS-2A	1.575 1.551	1.250	1.156		.202 .186		
H	23	1.5000-.1P-.3L-TS-2A	1.701 1.667	1.375	1.250	.162 .146	.250 .234	.171 .083	.791 .736
J	25	1.6250-.1P-.3L-TS-2A	1.823 1.799	1.500	1.375				

Shell Size Code	Shell Size	ø M Min.	ø N Min.	P Holes	R BSC
A	09	.656	.516	.133 .123	.719
G	21	1.422	1.266		1.250
H	23	1.547	1.375	.159 .149	1.375
J	25	1.672	1.484	.155 .145	1.500

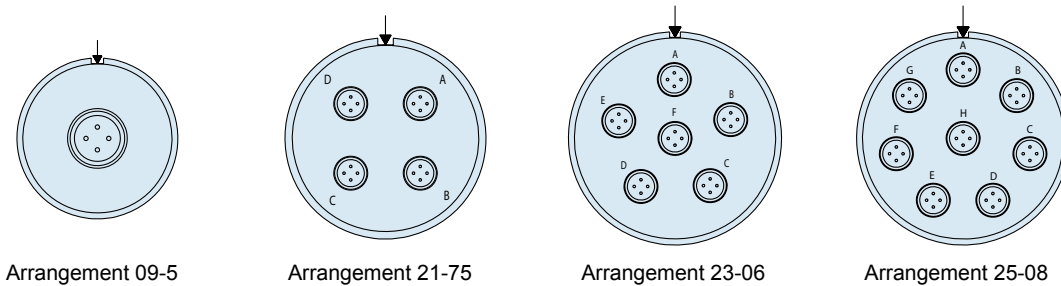

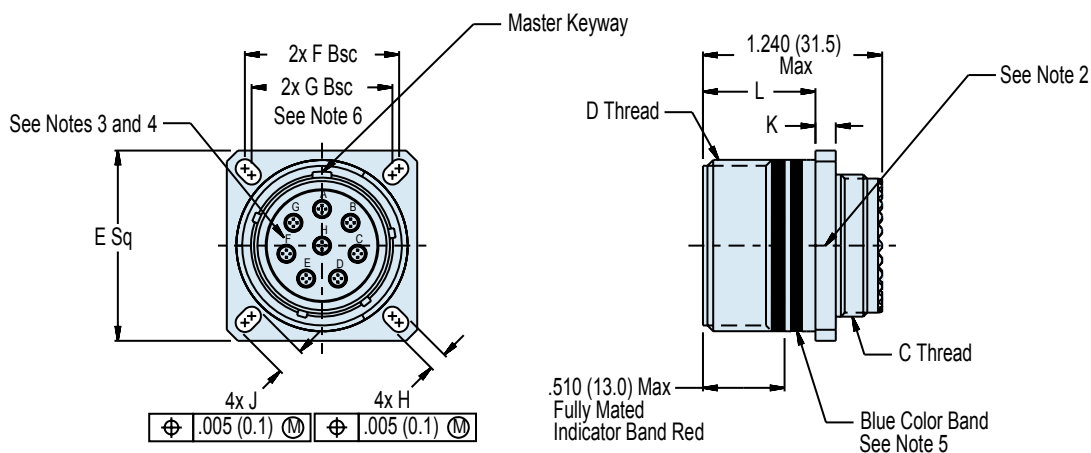
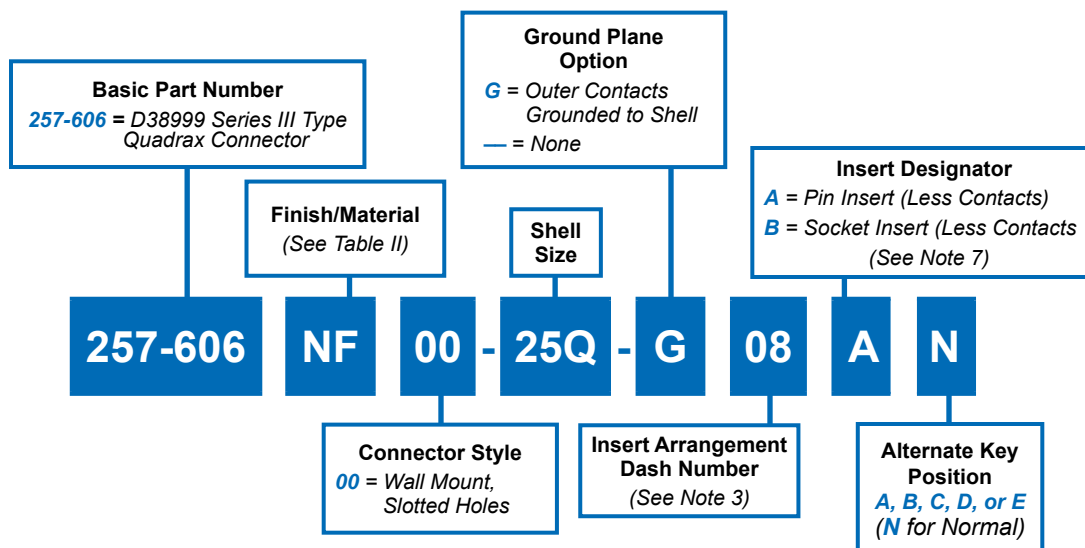

**00-Wall Mount Receptacle
With Slotted Holes**
(See Table I)

APPLICATION NOTES

- | | |
|--|---|
| 1. Material/Finish (See Table II). | 5. Blue color band indicates rear release retention system. |
| 2. Assembly identified with Glenair's, part number and date code | 6. Front panel mount only. |
| 3. Insert arrangements IAW MIL-STD-1560 and Figure 1. | 7. Parts will be identified "A" or "B." |
| 4. Insert arrangements shown is for reference only. | |

**257-606 (G6)
 Quadrax Plug Connector
 MIL-DTL-38999 Series III Type**

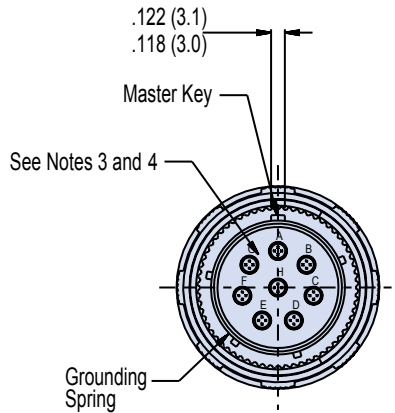
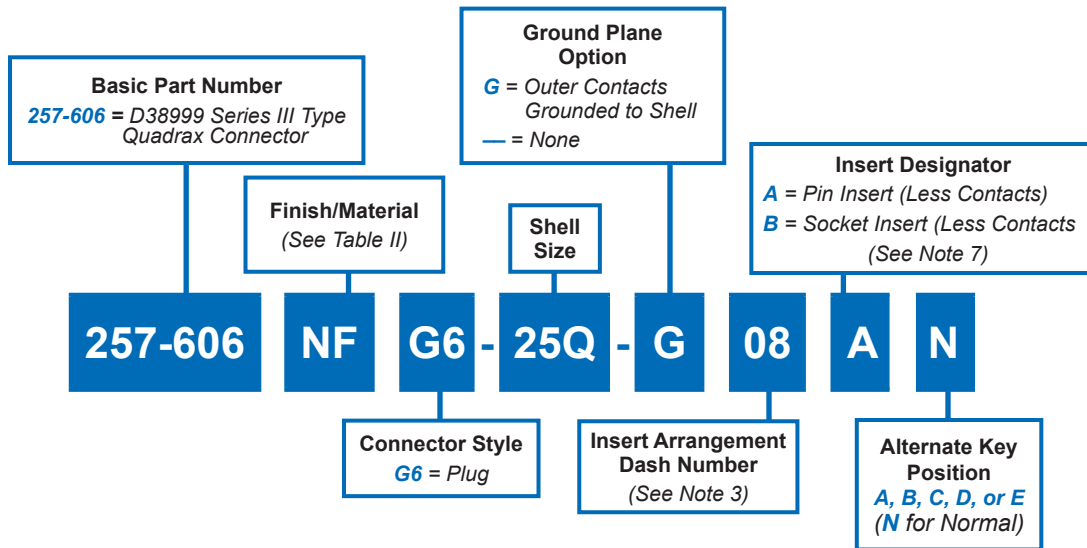

G6 - Plug
 (See Table III)

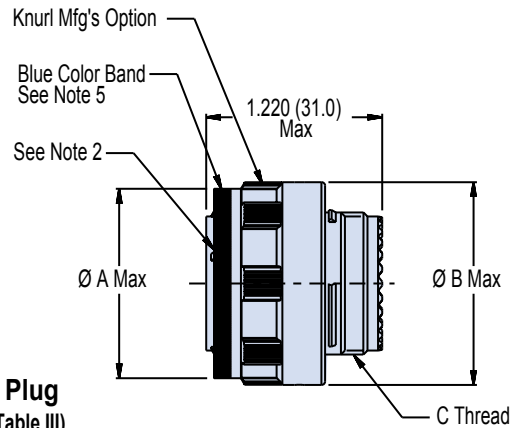

APPLICATION NOTES

1. Material/Finish (See Table II).
2. Assembly identified with Glenair's, part number and date code
3. Insert arrangements IAW MIL-STD-1560 and Figure 1.
4. Insert arrangements shown is for reference only.
5. Blue color band indicates rear release retention system.
6. Front panel mount only.
7. Parts will be identified "A" or "B."

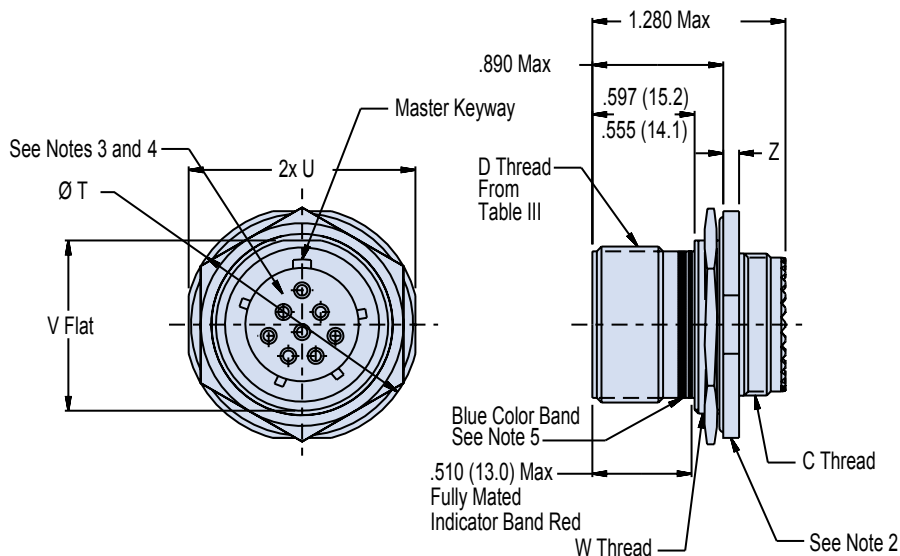
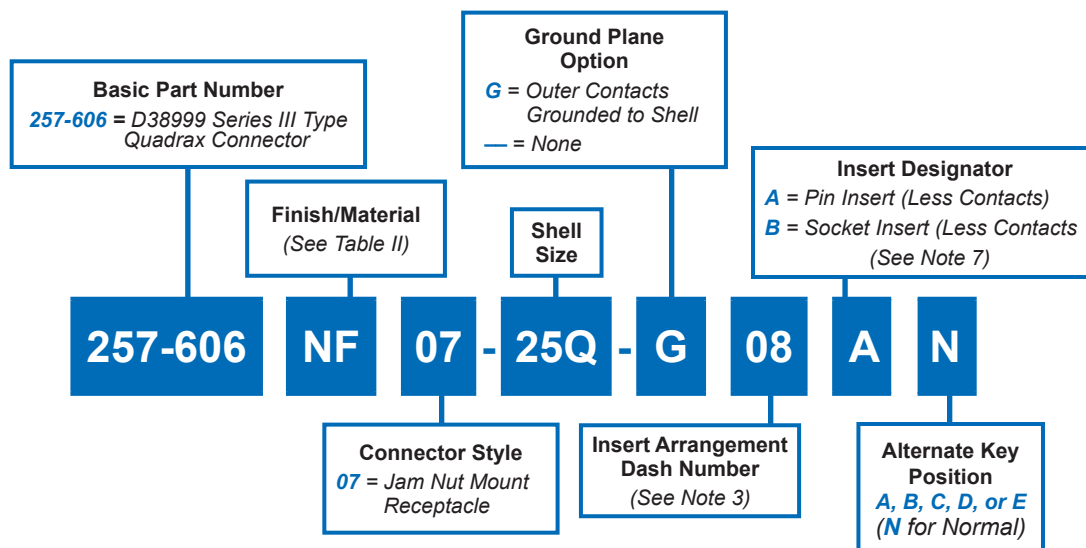

07 - Jam Nut Mount Receptacle
(See Table IV)

APPLICATION NOTES

- | | |
|--|---|
| 1. Material/Finish (See Table II). | 5. Blue color band indicates rear release retention system. |
| 2. Assembly identified with Glenair's, part number and date code | 6. Front panel mount only. |
| 3. Insert arrangements IAW MIL-STD-1560 and Figure 1. | 7. Parts will be identified "A" or "B." |
| 4. Insert arrangements shown is for reference only. | |

257-606
Quadrax Connector Dimensions,
Finish and Ground Plane • MIL-DTL-38999 Series III Type



TABLE I: G6 PLUG DIMENSIONS

Shell Size Code	Shell Size	ø A Max.	ø B Max.	C Thread
A	09	.811 (20.6)	.858 (21.8)	M12 x 1.0-6g 0.100R
B	11	.929 (23.6)	.984 (25.0)	M15 x 1.0-6g 0.100R
E	17	1.358 (34.5)	1.406 (35.7)	M25 x 1.0-6g 0.100R
F	19	1.469 (37.3)	1.516 (38.5)	M28 x 1.0-6g 0.100R
G	21	1.594 (40.5)	1.642 (41.7)	M31 x 1.0-6g 0.100R
H	23	1.720 (43.7)	1.768 (44.9)	M34 x 1.0-6g 0.100R
J	25	1.843 (46.8)	1.890 (48.0)	M37 x 1.0-6g 0.100R

TABLE II: MATERIAL/FINISH and GROUND PLANE

Sym	Material	Finish	Ground Plane
M	Aluminum	Electroless Nickel	1 mV
NF		Cadmium O.D. Over Electroless Nickel	2.5 mV
XM	Composite	Electroless Nickel	3.0 mV
XW		Cadmium O.D. over Electroless Nickel	3.0 mV

Consult Factory for Additional Plating Options

TABLE III: 00 WALL MOUNT DIMENSIONS

Shell Size Code	Shell Size	D Thread	E Sq.	F BSC	G BSC (See Note 6)	H	J	K	L
A	09	.6250-.1P-.3L-TS-2A	.949 (24.1) .925 (23.5)	.719 (18.3)	.626 (15.9)	.136 (3.5) .120 (3.0)	.224 (5.7) .208 (5.3)	.144 (3.7) .083 (2.1)	.823 (20.9) .768 (19.5)
B	11	.7500-.1P-.3L-TS-2A	1.043 (26.5) 1.019 (25.9)	.812 (20.6)	.719 (18.3)		.202 (5.1) .186 (4.7)		
E	17	1.1875-.1P-.3L-TS-2A	1.323 (33.6) 1.299 (33.0)	1.062 (27.0)	.969 (24.6)				
F	19	1.2500-.1P-.3L-TS-2A	1.449 (36.8) 1.425 (36.2)	1.156 (29.4)	1.062 (27.0)	.162 (4.1) .146 (3.7)	.250 (6.4) .234 (5.9)	.171 (4.3) .083 (2.1)	.791 (20.1) .736 (18.7)
G	21	1.3750-.1P-.3L-TS-2A	1.575 (40.0) 1.551 (39.4)	1.250 (31.8)	1.156 (29.4)				
H	23	1.5000-.1P-.3L-TS-2A	1.701 (43.2) 1.667 (42.3)	1.375 (34.9)	1.250 (31.8)	.162 (4.1) .146 (3.7)	.250 (6.4) .234 (5.9)	.171 (4.3) .083 (2.1)	.791 (20.1) .736 (18.7)
J	25	1.6250-.1P-.3L-TS-2A	1.823 (46.3) 1.799 (45.7)	1.500 (38.1)	1.375 (34.9)				



TABLE II: MATERIAL/FINISH

Sym	Material	Finish
M	Aluminum	Electroless Nickel
NF		Cadmium O.D. Over Electroless Nickel
MT		Ni-PTFE 1,000 Hour Grey™ (Nickel Fluorocarbon Polymer)
XM	Composite	Electroless Nickel
XW		Cadmium O.D. Over Electroless Nickel
XMT		Ni-PTFE 1,000 Hour Grey™ (Nickel Fluorocarbon Polymer)

Consult Factory for Additional Plating Options

TABLE IV: 07 JAM NUT MOUNT

Shell Size Code	Shell Size	øT	U	V Flat	W Thread	Z
A	09	1.200 (30.5) 1.178 (29.9)	1.078 (27.4) 1.048 (26.6)	.654 (16.6) .645 (16.4)	M17 x 1.0-6g 0.100R	.122 (3.1) .083 (2.1)
B	11	1.386 (35.2) 1.362 (34.6)	1.268 (32.2) 1.236 (31.4)	.755 (19.2) .745 (18.9)	M20 x 1.0-6g 0.100R	
E	17	1.764 (44.8) 1.740 (44.2)	1.642 (41.7) 1.610 (40.9)	1.191 (30.3) 1.181 (30.0)	M32 x 1.0-6g 0.100R (See Note 6)	
F	19	1.949 (49.5) 1.925 (48.9)	1.827 (46.4) 1.795 (45.6)	1.316 (33.4) 1.306 (33.2)	M35 x 1.0-6g 0.100R	.153 (3.9) .114 (2.9)
G	21	2.075 (52.7) 2.051 (52.1)	1.953 (49.6) 1.921 (48.8)	1.441 (36.6) 1.431 (36.3)	M38 x 1.0-6g 0.100R	
H	23	2.201 (55.9) 2.177 (55.3)	2.079 (52.8) 2.047 (52.0)	1.566 (39.8) 1.556 (39.5)	M41 x 1.0-6g 0.100R	
J	25	2.323 (59.0) 2.299 (58.4)	2.205 (56.0) 2.173 (55.2)	1.691 (43.0) 1.681 (42.7)	M44 x 1.0-6g 0.100R	

Recommended Mounting Holes Receptacle (See Table V)

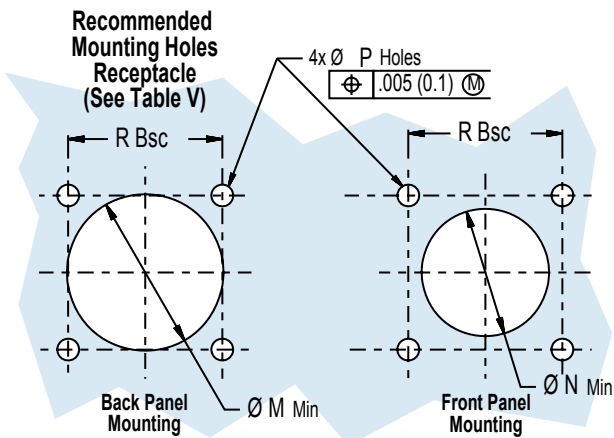

TABLE V: MOUNTING HOLE DIMENSIONS

Shell Size Code	Shell Size	øM Min	øN Min	P Holes	R BSC
A	09	.656 (16.7)	.516 (13.1)	.133 (3.4) .123 (3.1)	.719 (18.3)
B	11	.796 (19.5)	.625 (15.9)		.812 (20.6)
E	17	1.219 (31.0)	1.016 (25.8)		1.062 (27.0)
F	19	1.297 (32.4)	1.141 (29.0)	.159 (4.0) .149 (3.8)	1.156 (29.4)
G	21	1.422 (36.1)	1.266 (32.2)		1.250 (31.8)
H	23	1.547 (39.3)	1.375 (34.9)	.155 (3.9) .145 (3.7)	1.375 (34.9)
J	25	1.672 (42.5)	1.484 (37.7)		1.500 (38.1)

257-606
Quadrax Connector Insert Arrangements
MIL-DTL-38999 Series III Type (IAW MIL-STD-1560)



Twinax and
 Quadrax
 Connectors

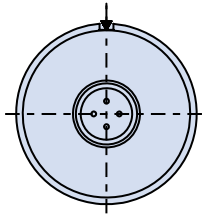

ARRANGEMENT 09Q-05

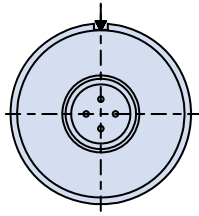

ARRANGEMENT 11Q-01

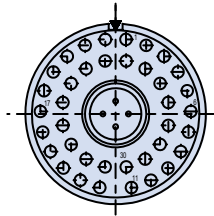

ARRANGEMENT 17Q-02
 1X SIZE 8 QUADRIX
 38X SIZE 22

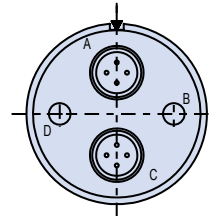

ARRANGEMENT 17Q-22
 (IAW PREN 3645-001)
 2X SIZE 8 QUADRIX
 2X SIZE 12

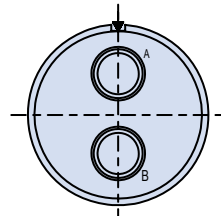

ARRANGEMENT 17Q-75
 (IAW PREN 3645-001)
 2X SIZE 8 QUADRIX

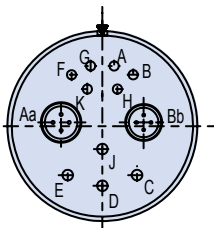

ARRANGEMENT 19Q-12
 6X SIZE 20
 4X SIZE 16
 2X SIZE 8 QUADRIX

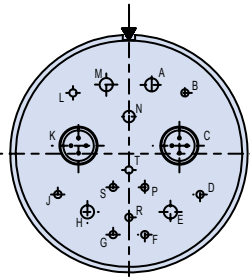

ARRANGEMENT 19Q-17
 10X SIZE 22D
 1X SIZE 20
 4X SIZE 16
 2X SIZE 8 QUADRIX

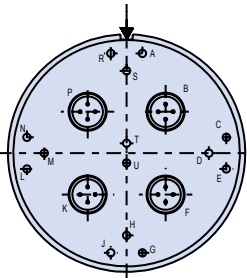

ARRANGEMENT 19Q-18
 14X SIZE 22D
 4X SIZE 8 QUADRIX

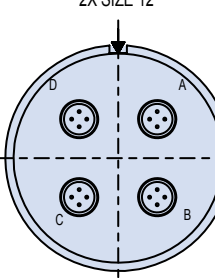

ARRANGEMENT 21Q-75
 4X SIZE 8 QUADRIX

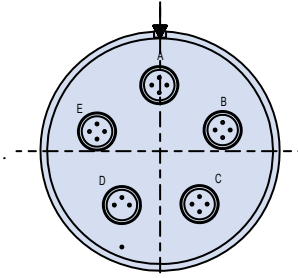

ARRANGEMENT 23Q-05
 (IAW PREN 3645-001)
 5X SIZE 8 QUADRIX

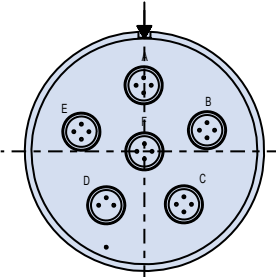

ARRANGEMENT 23Q-06
 (IAW PREN 3645-001)
 6X SIZE 8 QUADRIX

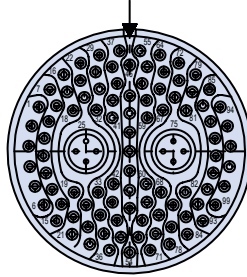

ARRANGEMENT 25Q-07
 97X SIZE 22
 2X SIZE 8 QUADRIX

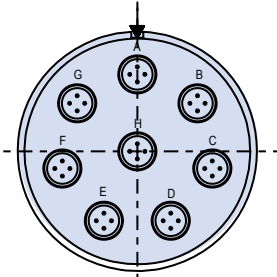

ARRANGEMENT 25Q-08
 8X SIZE 8 QUADRIX

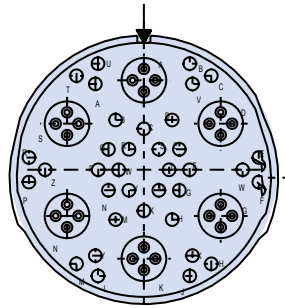

ARRANGEMENT 25Q-17
 36X SIZE 22
 6X SIZE 8 QUADRIX

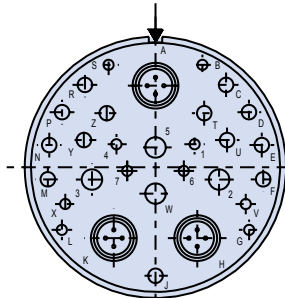

ARRANGEMENT 25Q-20
 (IAW PREN 3645-001)
 10X SIZE 20
 13X SIZE 16
 4X SIZE 12
 3X SIZE 8 QUADRIX

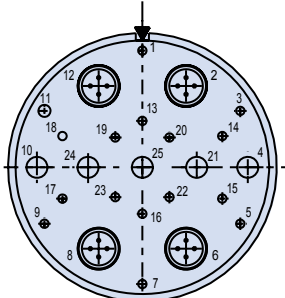

ARRANGEMENT 25Q-26
 (IAW PREN 3645-001)
 16X SIZE 20, 5X SIZE 12
 4X SIZE 8 QUADRIX

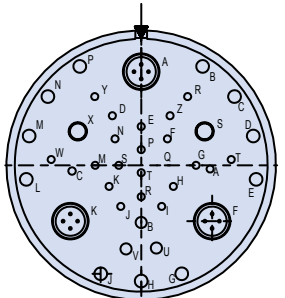

ARRANGEMENT 25Q-41
 22X SIZE 22D, 3X SIZE 20
 11X SIZE 16, 2X SIZE 12

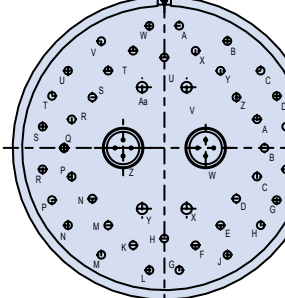

ARRANGEMENT 25Q-46
 40X SIZE 20
 4X SIZE 16

Mating Face of Pin Insert Shown





257-616 Twinax and Quadrax PC Tail Contacts MIL-DTL-38999 Series III Type

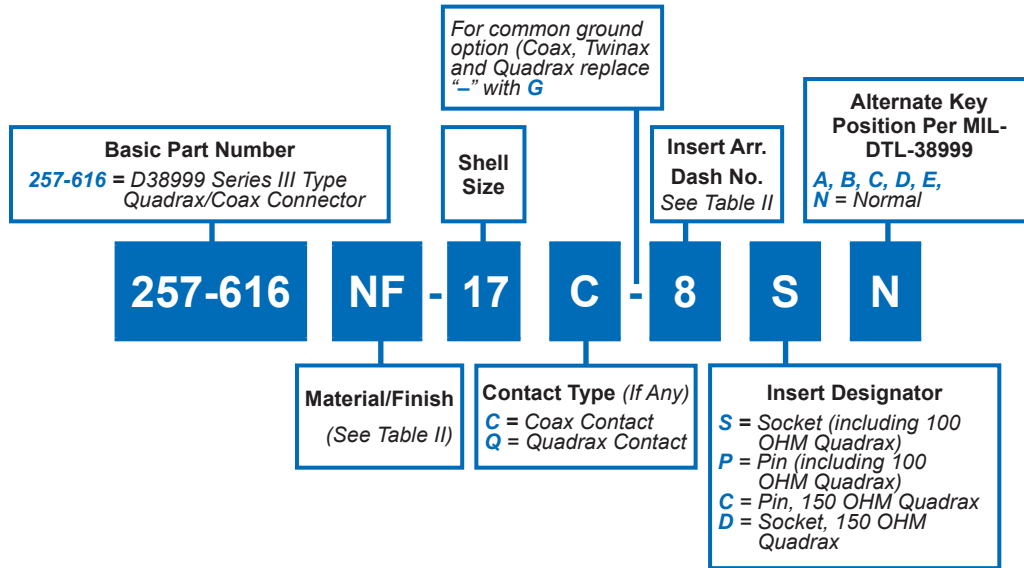

TABLE I: DIMENSIONS

Shell Size Code	Shell Size	A Thread	B Sq		C Bsc		D	E	Ø G		J Holes
			In	mm	In	mm					
A	9	.6250-1P-.3L-TS-2A	1.015 1.005	25.78 25.53	.719	18.26	.171 .083 (4.34) (2.11)	.791 .736 (20.09) (18.64)	0.656	16.66	.125 (3.18) Min
B	11	.7500-.1P-.3L-TS-2A	1.015 1.005	25.78 25.53	.812	20.62			0.796	20.22	
C	13	.8750-.1P-.3L-TS-2A	1.218 1.186	30.94 30.12	.906	23.01			0.921	23.39	
D	15	1.0000-.1P-.3L-TS-2A	1.286 1.254	32.66 31.85	.969	24.61			1.047	26.59	
E	17	1.1875-.1P-.3L-TS-2A	1.366 1.334	34.70 33.88	1.062	26.97			1.219	30.96	
F	19	1.2500-.1P-.3L-TS-2A	1.449 1.425	36.80 36.20	1.156	29.36			1.296	32.92	
G	21	1.3750-.1P-.3L-TS-2A	1.575 1.545	40.01 39.24	1.250	31.75			1.421	36.09	
H	23	1.5000-.1P-.3L-TS-2A	1.701 1.677	43.21 42.60	1.375	34.93			1.547	39.29	
J	25	1.6250-.1P-.3L-TS-2A	1.823 1.799	46.30 45.69	1.500	38.10			1.672	42.47	

Table II: Material and Finish

Symbol	Material	Finish Description
M	Aluminum	Electroless Nickel
MT		Nickel-PTFE
NF		Cadmium O.D. Over Electroless Nickel

257-616
Twinax and Quadrax PC Tail Contacts
MIL-DTL-38999 Series III Type

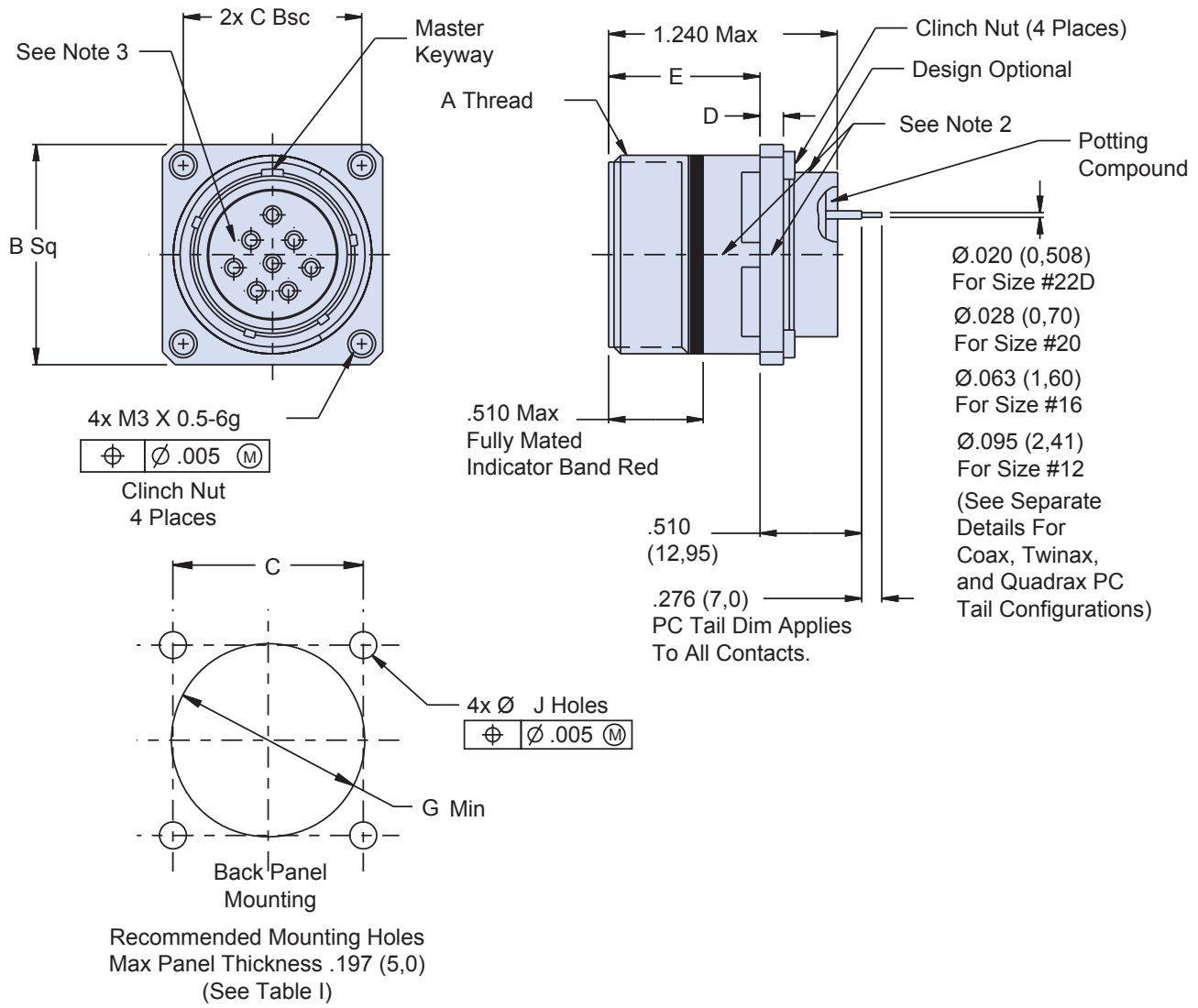



257-616 Twinax and Quadrax PC Tail Contacts MIL-DTL-38999 Series III Type

COAX CONTACT

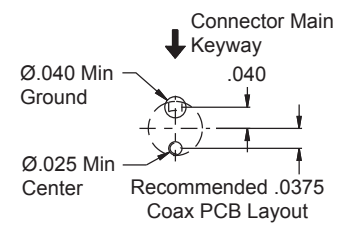
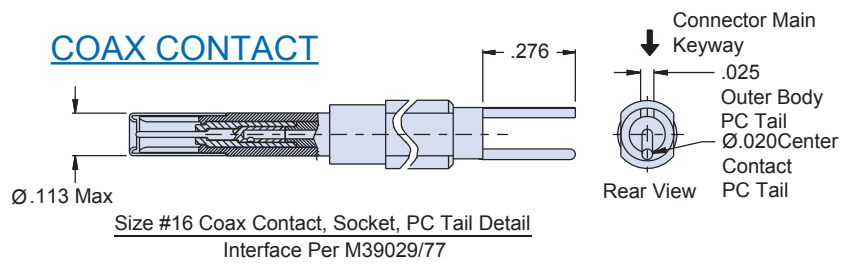

TWINAX CONTACT

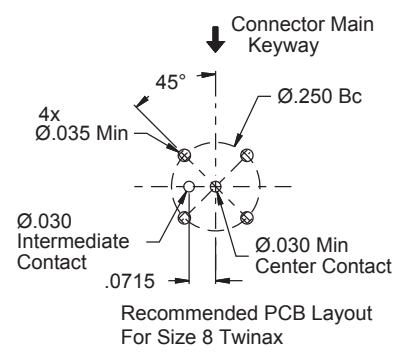
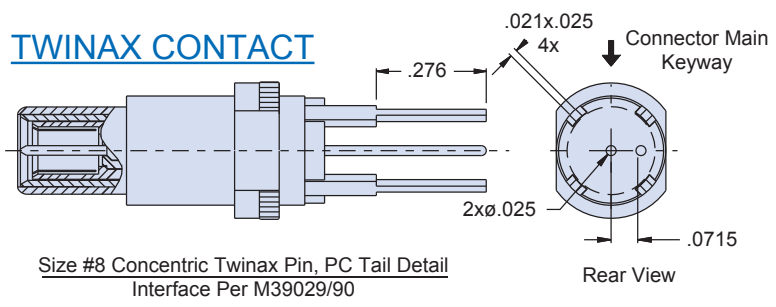

E

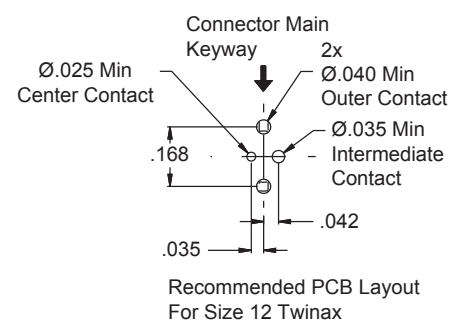
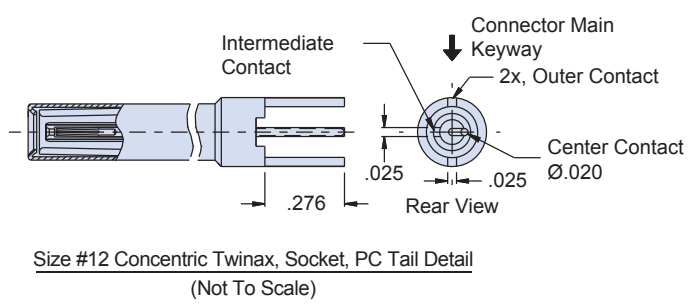

QUADRIX CONTACT

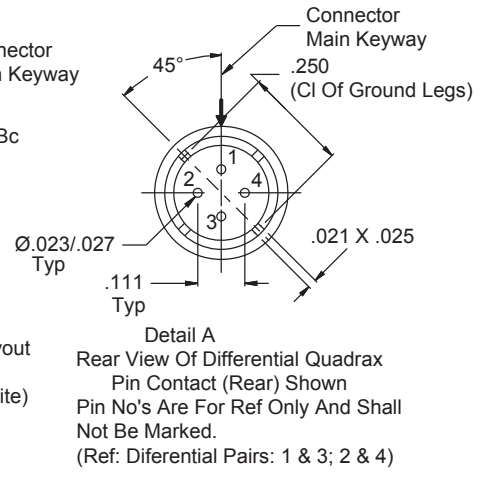
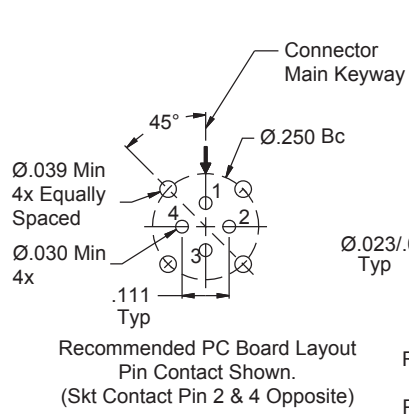
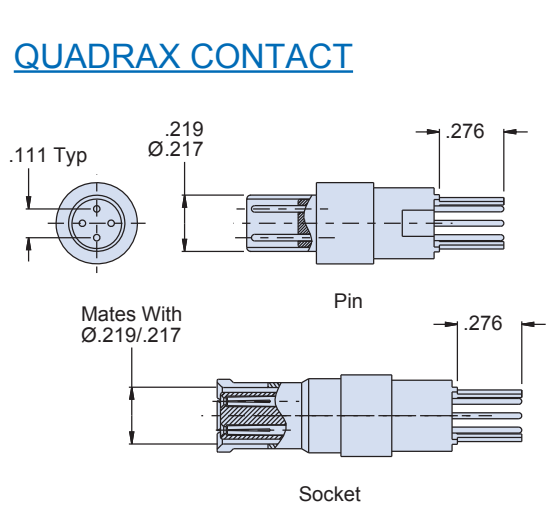

257-616
Twinax and Quadrax PC Tail Contacts
 MIL-DTL-38999 Series III Type Insert Arrangements



TABLE II: INSERT ARRANGEMENTS
 (not all arrangements shown, other arrangements available upon request)

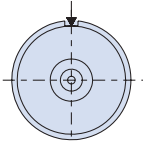

Arrangement 9-5
 Available Only 9G5 (Common Ground Option)
 Size 8 Concentric Twinax

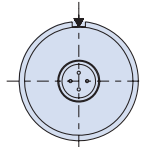

Arrangement 09QG05
 (Common Ground Option Only)
 Size 8 Quadrax Contact

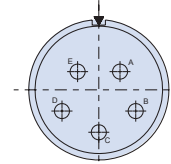

Arrangement 11-5
 Size 20 Contact
 5 Places

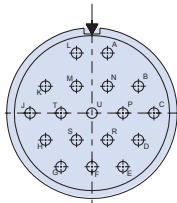

Arrangement 15-18
 Size 20 Contact
 18 Places

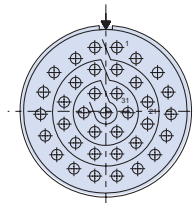

Arrangement 15-35
 Size 22D Contact
 37 Places

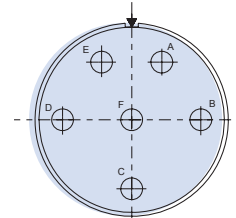

Arrangement 17-6
 Size 12 Contact
 6 Places

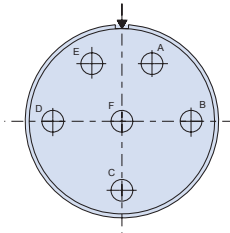

Arrangement 17t-6
 17TG6 (Common Ground Option)
 Size 12 Twinax Contact, 6 Places

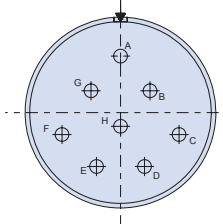

Arrangement 17C-8
 17CG8 (Common Ground Option)
 Size 16 Coax Contact, 8 Places

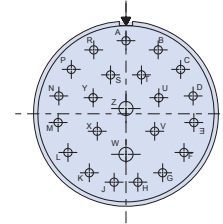

Arrangement 17-99
 Size 16 Skt Contact, 2 Places
 Size 20 Skt Contact, 21 Places

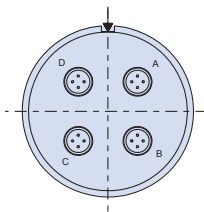

Arrangement 21Q-75
 Size 8 Gage Quadrax, 4 Places

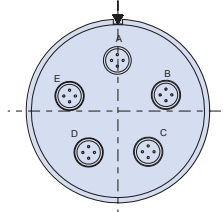

Arrangement 23Q-05
 Size 8 Quadrax, 5 Places

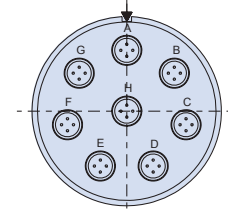

Arrangement 25Q-08
 Size 8 Gage Quadrax, 8 Places

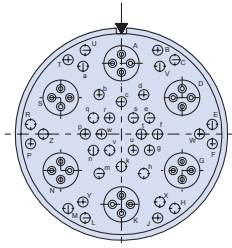

Arrangement 25Q-17
 Size 22D Contact, 36 Places

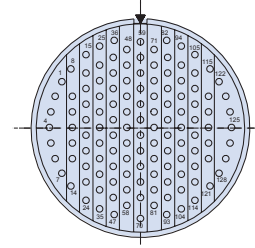

Arrangement 25-35
 Size 22D Contact, 128 Places



854-001 and 854-002 Crimp Quadrax Pin and Socket Contacts MIL-DTL-38999 Series III Type

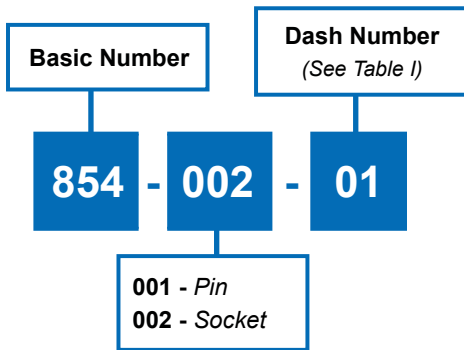
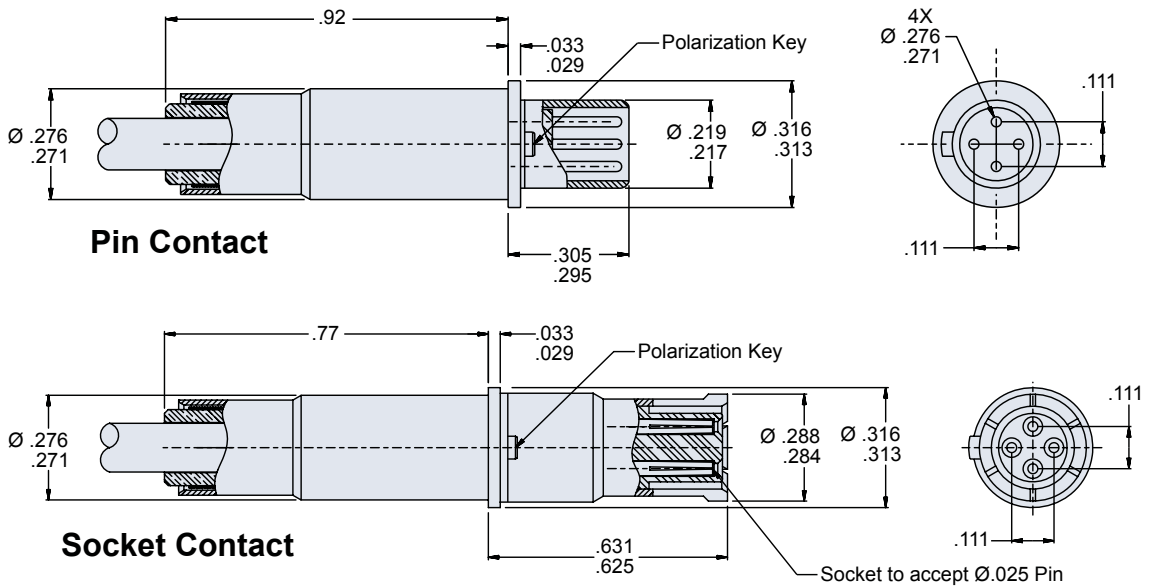

TABLE I	
Dash Number	Cables Accomodated
-01	Tensolite NF26Q100
-02	Tensolite NF24Q100
-03	Draka Fileca F 4704-6
-04	Draka Fileca F 4704-4



PRODUCT ORDERING INFORMATION							
Contact Size	Type	Glenair Part Number	Military Part Number	Tool Code	Cable Type Dash No.	Wire Size	Sample Contact
#8	Quadrax	854-001	N/A	C, J (Inner) K, M (Outer)	-01 - Tensolite NF26Q100	26AWG	
		854-002			-02 - Tensolite NF24Q100	24AWG	
					-03 - Draka Fileca F 4704-6	26AWG	
					-04 - Draka Fileca F 4704-4	24AWG	

APPLICATION NOTES	
1. Assembly to be bagged and tagged with Glenair's name, part number and date code.	3. Electrical Parameters: Differential impedance - 100 ohms nominal Dielectric withstanding voltage - 500 VRMS Insulation resistance - 5000 megohms minimum at 200 VDC
2. Material/Finish: Contact body - Copper alloy / Gold plated Inner contacts - Copper alloy / Gold plated Crimp ferrule - Brass or equivalent / Gold plated Insulator - Teflon, Ultem series 1000 or equivalent	4. Contact is designed to accomodate cable listed in table I
	5. Pin contact shall mate with Glenair socket contact p/n 854-001-xx and fit into Glenair connector series 257-459 only.

Glenair Environmental and Hermetic MIL-DTL-38999 Type Bulkhead Feed-Thrus

SECTION F TABLE OF CONTENTS

GLENAIR MIL-DTL-38999 TYPE BULKHEAD FEED-THRUS:

MIL-DTL-38999 Type Bulkhead Feed-Thru Product Features.....	F-1
231-103-H7 Series I Type Jam Nut Mount Hermetic Bulkhead Feed-Thru.....	F-2
231-104-00 Series I Type Wall Mount Environmental Bulkhead Feed-Thru.....	F-3
231-104-07 Series I Type Jam Nut Mount Environmental Bulkhead Feed-Thru.....	F-4
231-104-09 Series I Type Jam Nut Mount Env. Plug/Receptacle Bulkhead Feed-Thru.....	F-5
947-101 Series I Type Flange Mount Pressure Vessel Penetrator.....	F-6
232-103-H7 Series II Type Jam Nut Mount Hermetic Bulkhead Feed-Thru.....	F-7
232-104-00 Series II Type Wall Mount Environmental Bulkhead Feed-Thru.....	F-8
233-103-H7 Series III Type Jam Nut Mount Hermetic Bulkhead Feed-Thru.....	F-10
233-104-00 Series III Type Wall Mount Environmental Bulkhead Feed-Thru.....	F-11
233-104-07 Series III Type Jam Nut Mount Environmental Bulkhead Feed-Thru.....	F-12
233-103-H9 Series III Type Jam Nut Mount Hermetic Plug/Receptacle Bulkhead Feed-Thru.....	F-13
947-112 Series III Type Jam Nut Mount Pressure Vessel Penetrator.....	F-14

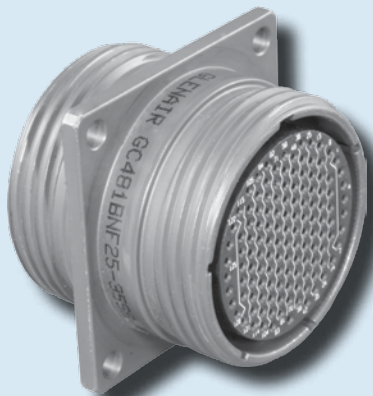

The Widest Range of MIL-DTL-38999 Type Bulkhead Feed-Thru Connectors Available In The Industry.

Product Applications

Bulkhead feed-thrus eliminate the need to permanently fix cable harnesses to panels—affording increased system flexibility, superior mechanical integrity, and greater serviceability. Glenair hermetic and environmental bulkhead feed-thru connectors are available in MIL-DTL-38999 Series I, II and III configurations. Hermetic Versions are ideally suited for high-pressure/low-leakage applications in air, sea and space environments, meeting a leak rate of 1×10^{-7} cm³ per second. Environmental versions offer IP67 level sealing.

Errata

Catalog contents—including part numbers, materials and dimensions—are accurate to the best of our ability when we go to print. Even so, customers are advised to consult the factory for the latest specifications, particularly to confirm critical dimensions such as connector lengths, threads, and so on. When errors or mistakes are brought to our attention, corrected content is posted immediately to our website: www.glenair.com.

TABLE I: MATERIALS

Shell, Barrel, and Coupling Nut (Environmental)	Aluminum alloy 6061 per ASTM-B211
Shell, Barrel Coupling and Jam Nut (Hermetic)	Stainless steel per AMS-QQ-S-763
Shell, Barrel, Coupling Nut and Jam Nut (Hermetic)	Carbon Steel per ASTM-B545 or ASTM-B339
Grommet, Peripheral Seal and Interfacial Seal	Blended elastomer, 30% silicone per ZZ-R-765, 70% fluorosilicone per MIL-R-25988
Hermetic Insert	Vitreous glass
Feed-Thru Contacts (Environmental)	Copper Alloy / Gold Plate
Feed-Thru (Hermetic)	Nickel-iron alloy per ASTM F30 (Alloy 52), 50 microinches gold plated per ASTM B488 Type 3 Code C Class 1, 27 over nickel plate per QQ-N-290 Class 2, 50-100 microinches
Adhesives	Silicone and epoxy

TABLE II: POPULAR FINISHES

Plating Code	Material	Finish	Specification
M	Aluminum	Electroless Nickel	AMS-C-26074
NF	Aluminum	Cadmium Plate Olive Drab over Electroless Nickel	AMS-QQ-P-416, over AMS-C-26074 (1000 Hour Salt Spray)
NC	Aluminum	Zinc-Cobalt	ASTMB840
ZN	Aluminum	Olive Drab Zinc-Nickel	Zinc alloy per ASTM B841-91, Class 1 Type E Grade 3 over Electroless nickel per ASTM B733-90 SC2, Type 1 Class 5
MT	Aluminum	Ni-PTFE 1,000 Hour Grey™ (Nickel Fluorocarbon Polymer)	MIL-DTL-38999L (500 Hour Salt Spray)
AL	Aluminum	Pure Electrodeposited Aluminum	MIL-DTL-83488 (1000 Hour Salt Spray)
Z1	Stainless Steel	Passivate	AMS-QQ-P-35
FT	Carbon Steel	Fused Tin Plate	ASTM-B545 or ASTM-B339
ZL	Stainless Steel	Electrodeposited Nickel	SAE-AMS-QQ-N-290, Class 2





231-103-H7 Jam Nut Mount Hermetic Bulkhead Feed-Thru MIL-DTL-38999 Series I Type

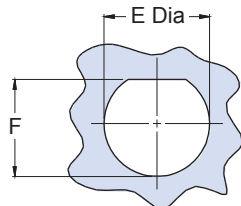
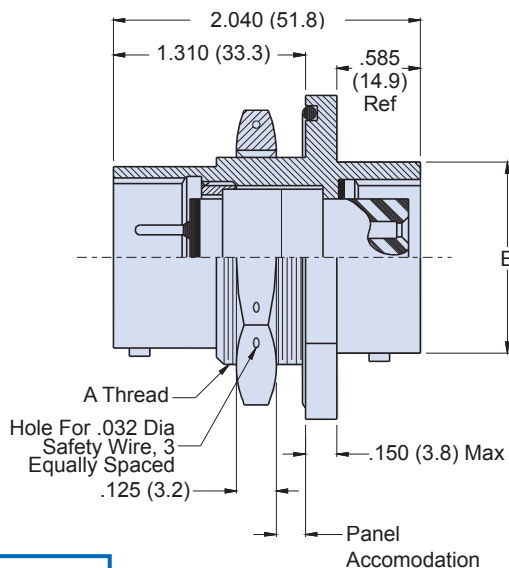
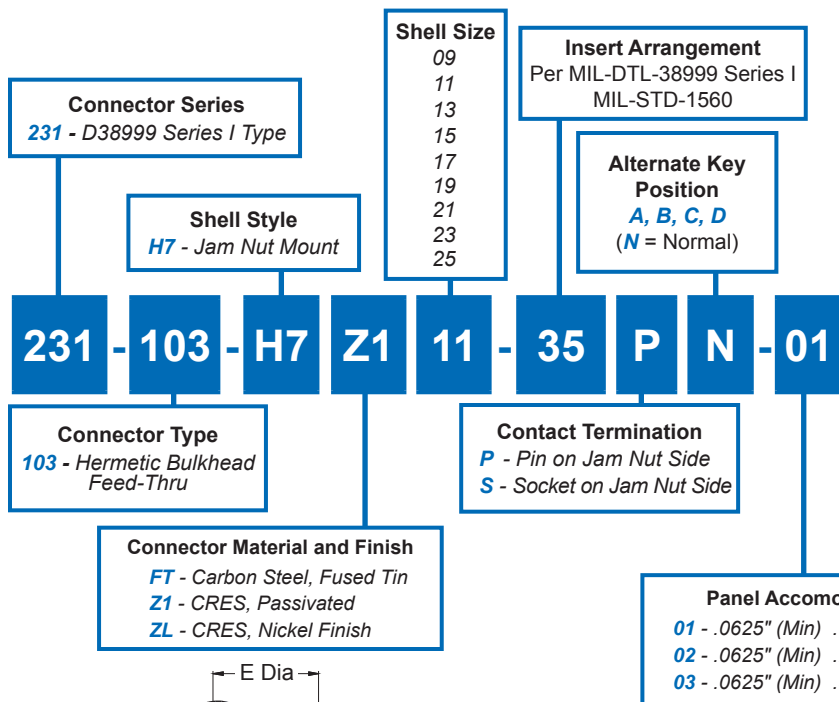

Recommended Panel Cut-Out

TABLE I: CONNECTOR DIMENSIONS

SHELL SIZE	A THREAD CLASS 2A	B DIA MAX	C HEX	D FLATS	E DIA ±.005(0.1)	F +.000-.005 (0-0.1)
09	.688-24 UNEF	.573(14.6)	.875(22.2)	1.062(27.0)	.703(17.9)	.669(17.0)
11	0.812-20 UNEF	.701(17.8)	1.000(25.4)	1.250(31.8)	.827(21.0)	.769(19.5)
13	1.000-20 UNEF	.851(21.6)	1.188(30.2)	1.375(34.9)	1.015(25.8)	.955(24.3)
15	1.125-18 UNEF	.976(24.8)	1.312(33.3)	1.500(38.1)	1.140(29.0)	1.084(27.5)
17	1.250-18 UNEF	1.101(28.0)	1.438(36.5)	1.625(41.3)	1.265(32.1)	1.208(30.7)
19	1.375-18 UNEF	1.208(30.7)	1.562(39.7)	1.812(46.0)	1.390(35.3)	1.333(33.9)
21	1.500-18 UNEF	1.333(33.9)	1.688(42.9)	1.938(49.2)	1.515(38.5)	1.459(37.1)
23	1.625-18 UNEF	1.458(37.0)	1.812(46.0)	2.062(52.4)	1.640(41.7)	1.580(40.1)
25	1.750-18 UNS	1.583(40.2)	2.000(50.8)	2.188(55.6)	1.765(44.8)	1.709(43.4)

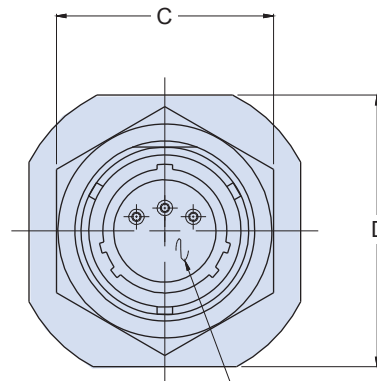

Insert Arrangement per MIL-DTL-38999, Series I MIL-STD-1560

APPLICATION NOTES

- Power to a given contact on one end will result in power to contact directly opposite, regardless of identification letter.
- Hermeticity = less than 1×10^{-4} cc/sec at one atmosphere. Not for use in liquid atmosphere.
- Material/finish:
Shell, nut – CRES/passivated, carbon steel/fused tin or CRES/nickel per QQ-N-290.
- Contacts – Gold Plated. Pin: alloy 52; Skt.: copper alloy
Insulator – fused vitreous glass/N.A.
Seals – fluorosilicone rubber/N.A.
- Metric dimensions (mm) are indicated in parentheses.

231-104-00 Wall Mount Environmental Bulkhead Feed-Thru MIL-DTL-38999 Series I Type

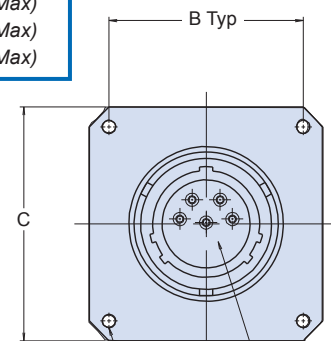
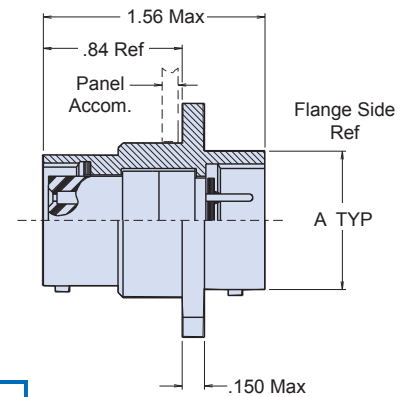
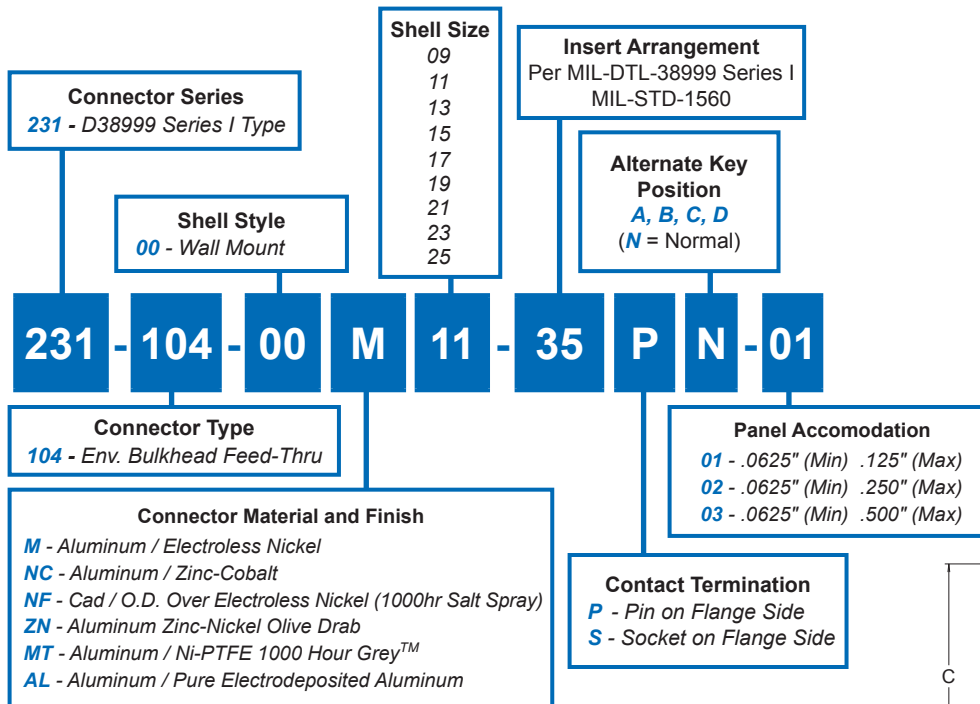

Insert Arrangement per MIL-DTL-38999, Series I MIL-STD-1560

TABLE I: CONNECTOR DIMENSIONS					
SHELL SIZE	A MAX	B SQ	C SQ	D DIA	E ±.005(0.1)
09	.573(14.6)	.719(18.3)	.938(23.8)	.125(3.2)	.703(17.9)
11	.701(17.8)	.812(20.6)	1.031(26.2)	.125(3.2)	.827(21.0)
13	.851(21.6)	.906(23.0)	1.125(28.8)	.125(3.2)	1.015(25.8)
15	.976(24.8)	.969(24.6)	1.219(31.0)	.125(3.2)	1.140(29.0)
17	1.101(28.0)	1.062(27.0)	1.312(33.3)	.125(3.2)	1.265(32.1)
19	1.208(30.7)	1.156(29.4)	1.438(36.5)	.125(3.2)	1.390(35.3)
21	1.333(33.9)	1.250(31.8)	1.562(39.7)	.125(3.2)	1.515(38.5)
23	1.458(37.0)	1.375(34.9)	1.688(42.9)	.156(4.0)	1.640(41.7)
25	1.583(40.2)	1.500(38.1)	1.812(46.0)	.156(4.0)	1.765(44.8)

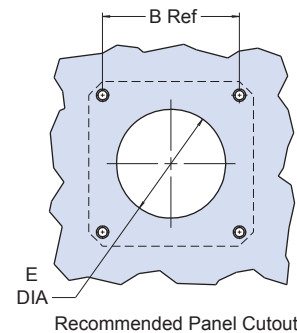

Recommended Panel Cutout

APPLICATION NOTES

- Material/finish:
Shells and nuts – Al alloy, 6061-T6, QQ-A-225/8, see Table I (D5)
Contacts – Leaded nickel copper/gold plate MIL-G-45204, Type II, Class I
Bayonet pins – AISI 300 series stainless steel/passivate, QQ-P-35
Hoods – AISI 305 series stainless steel/passivate, QQ-P-35
Inserts – Epiall 1908
Seals – Silicone per ZZ-R-765
- Metric Dimensions (mm) are indicated in parentheses.



231-104-07 Jam Nut Environmental Bulkhead Feed-Thru MIL-DTL-38999 Series I Type

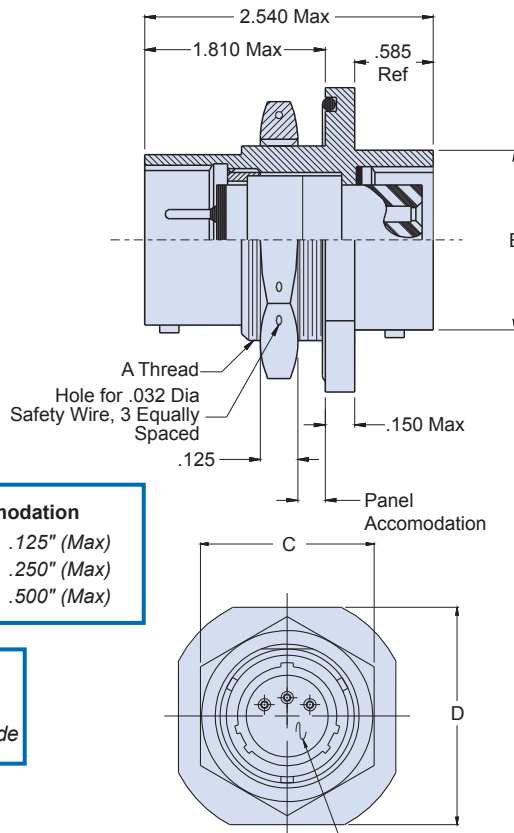
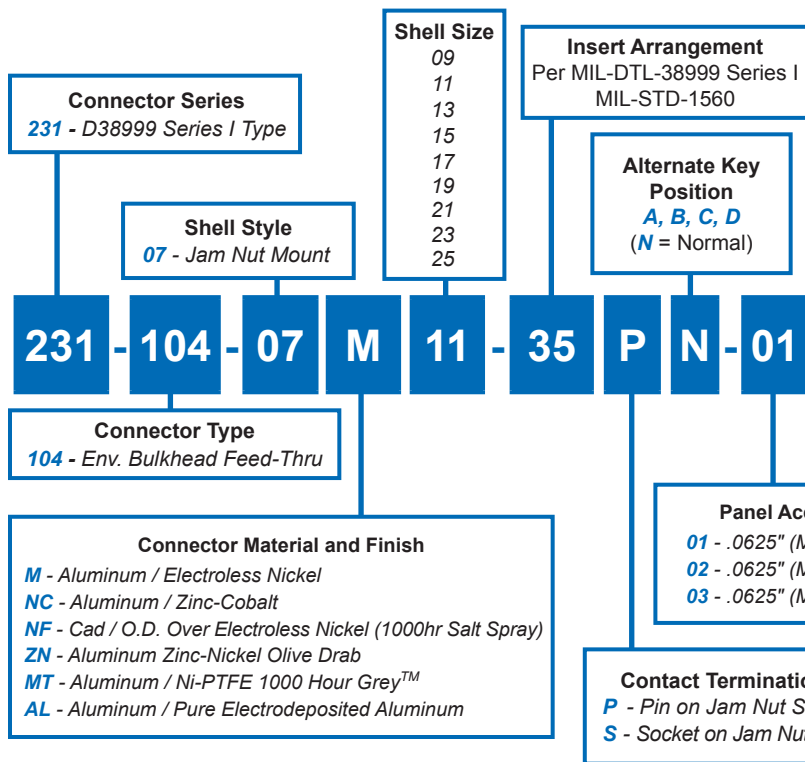

Insert arrangement, per MIL-C-38999, Series I MIL-STD-1560

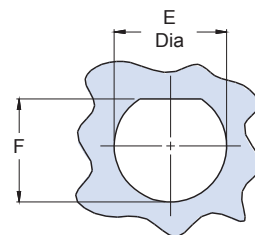

Recommended Panel Cut-Out

TABLE I: CONNECTOR DIMENSIONS

SHELL SIZE	A THREAD CLASS 2A	B DIA MAX	C HEX	D FLATS	E DIA ±.005(0.1)	F +.000-.002 (0-.06)
09	.688-24 UNEF	.573(14.6)	.875(22.2)	1.062(27.0)	.678(17.7)	.657(16.70)
11	.813-20 UNEF	.701(17.8)	1.000(25.4)	1.250(31.8)	.830(21.1)	.771(19.59)
13	1.000-20 UNEF	.851(21.6)	1.188(30.2)	1.375(34.9)	1.015(25.8)	.955(24.26)
15	1.125-18 UNEF	.976(24.8)	1.312(33.3)	1.500(38.1)	1.140(29.0)	1.085(27.56)
17	1.250-18 UNEF	1.101(28.0)	1.438(36.5)	1.625(41.3)	1.265(32.1)	1.210(30.73)
19	1.375-18 UNEF	1.208(30.7)	1.562(39.7)	1.812(46.0)	1.390(35.3)	1.335(33.91)
21	1.500-18 UNEF	1.333(33.9)	1.688(42.9)	1.938(49.2)	1.515(38.5)	1.460(37.08)
23	1.625-18 UNEF	1.458(37.0)	1.812(46.0)	2.062(52.4)	1.640(41.7)	1.585(40.26)
25	1.750-18 UNS	1.583(40.2)	2.000(50.8)	2.188(55.6)	1.765(44.8)	1.710(43.43)

APPLICATION NOTES

- Power to a given contact on one end will result in power to contact directly opposite regardless of identification letter
- Metric Dimensions (mm) are indicated in parentheses
- Material/finish:
Shell, locking, jam nut—Al alloy, See Table II Page D-5

Contacts—Copper alloy/gold plate
Insulators—High grade rigid dielectric/N.A.
Bayonet Pins—CRES/passivate
Seals—silicone/N.A.

231-104-09 Jam Nut Mount Environmental Plug/Receptacle Bulkhead Feed-Thru for MIL-DTL-38999 Series I Type



Bulkhead
Feed-Thru

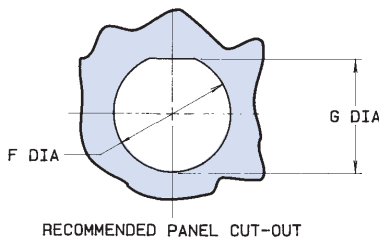
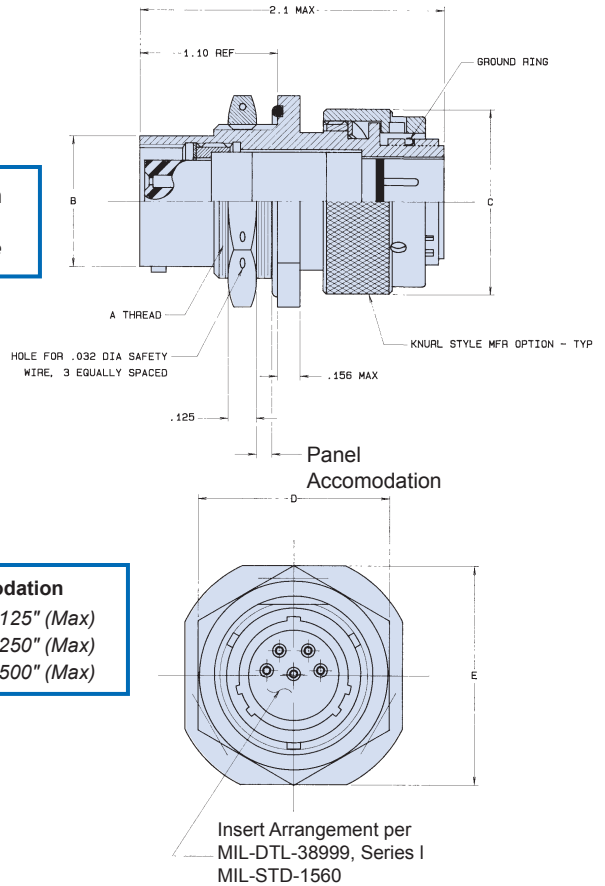
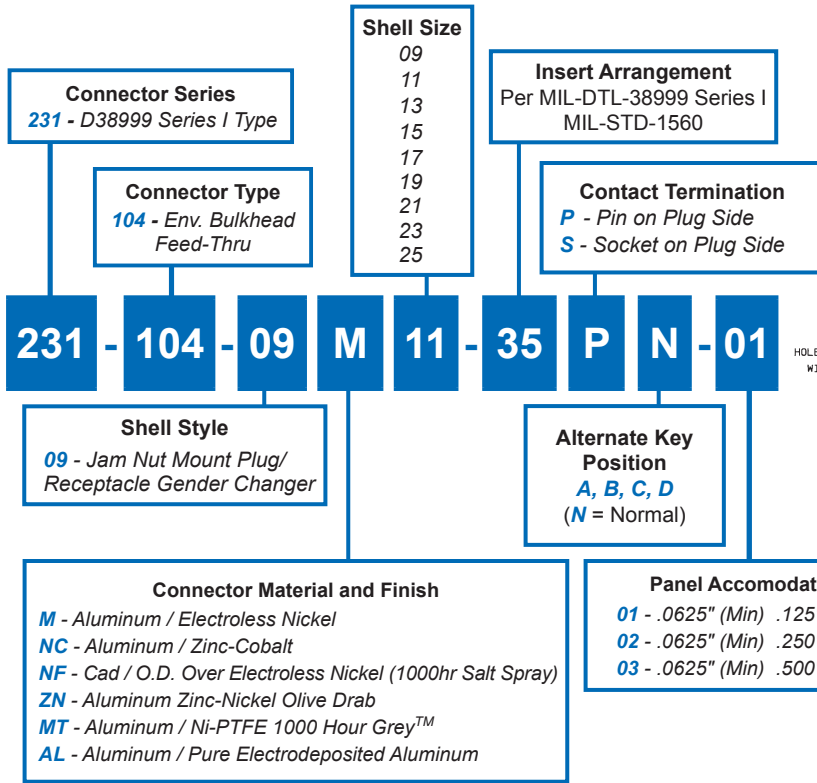

TABLE I: CONNECTOR DIMENSIONS

SHELL SIZE	A THREAD CLASS 2A	B DIA MAX	C MAX	D HEX	E FLATS	F DIA .005(0.1)	G +.000-.005 (0-0.1)
09	.688-24 UNEF	.573(14.6)	.900(22.9)	.875(22.2)	1.062(27.0)	.703(17.9)	.699(17.8)
11	0.813-20 UNEF	.701(17.8)	1.030(26.2)	1.000(25.4)	1.250(31.8)	.827(21.0)	.769(19.5)
13	1.000-20 UNEF	.851(21.6)	1.205(30.6)	1.188(30.2)	1.375(34.9)	1.015(25.8)	.955(24.3)
15	1.125-18 UNEF	.976(24.8)	1.325(33.7)	1.312(33.3)	1.500(38.1)	1.140(29.0)	1.084(27.5)
17	1.250-18 UNEF	1.101(28.0)	1.450(36.8)	1.438(36.5)	1.625(41.3)	1.265(32.1)	1.208(30.7)
19	1.375-18 UNEF	1.208(30.7)	1.565(39.8)	1.562(39.7)	1.812(46.0)	1.390(35.3)	1.333(33.9)
21	1.500-18 UNEF	1.333(33.9)	1.690(42.9)	1.688(42.9)	1.938(49.2)	1.515(38.5)	1.459(37.1)
23	1.625-18 UNEF	1.458(37.0)	1.795(45.6)	1.812(46.0)	2.062(52.4)	1.640(41.7)	1.580(40.1)
25	1.750-18 UNS	1.583(40.2)	1.920(48.8)	2.000(50.8)	2.188(55.6)	1.765(44.8)	1.709(43.4)

APPLICATION NOTES

- Material/finish:
Shell assembly, coupling nut, jam nut, lock ring—Aluminum Alloy, See Table II
Contacts—Copper alloy/gold plate
Bayonet pins, wave washer—CRES/passivate
 - O-Ring, interfacial and peripheral seals—silicone/N.A.
Insulators—High grade rigid dielectric/N.A.
Ground Ring—Beryllium copper/gold plate
2. Metric Dimensions (mm) are indicated in parentheses.

F



947-101
Flange Mount Environmental
Bulkhead Feed-Thru
1.00in Panel • MIL-DTL-38999 Series I Type

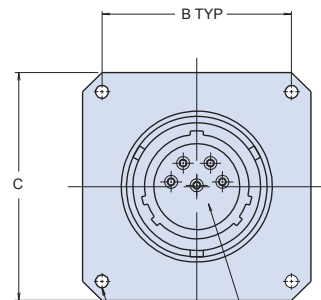
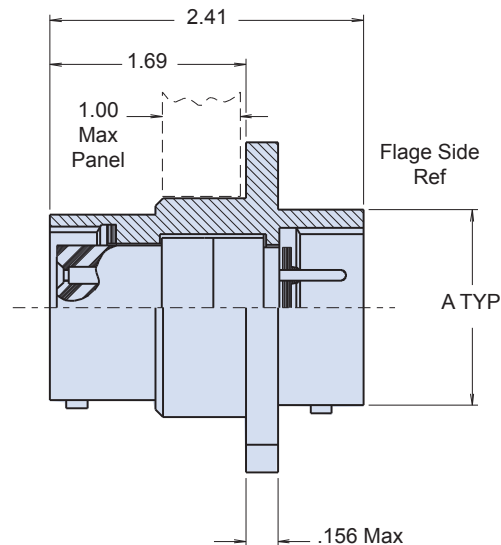
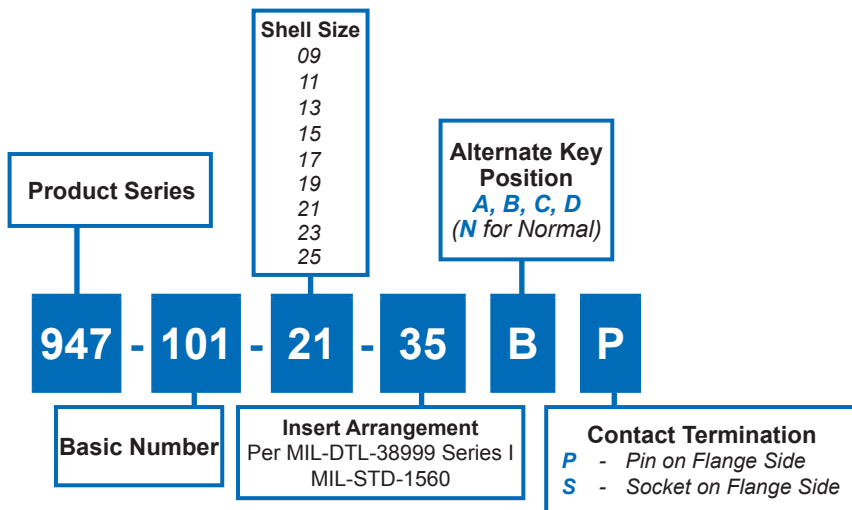

Insert Arrangement per MIL-DTL-38999, Series I
D Dia Typ

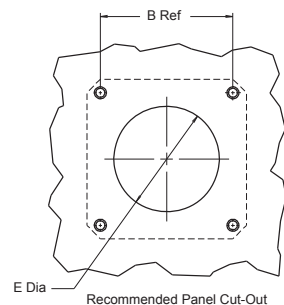

TABLE I: CONNECTOR DIMENSIONS

SHELL SIZE	A MAX	B SQ	C SQ	D DIA	E ±.005(0.1)
09	.573(14.6)	.719(18.3)	.938(23.8)	.125(3.2)	.703(17.9)
11	.701(17.8)	.812(20.6)	1.031(26.2)	.125(3.2)	.827(21.0)
13	.851(21.6)	.906(23.0)	1.125(28.8)	.125(3.2)	1.015(25.8)
15	.976(24.8)	.969(24.6)	1.219(31.0)	.125(3.2)	1.140(29.0)
17	1.101(28.0)	1.062(27.0)	1.312(33.3)	.125(3.2)	1.265(32.1)
19	1.208(30.7)	1.156(29.4)	1.438(36.5)	.125(3.2)	1.390(35.3)
21	1.333(33.9)	1.250(31.8)	1.562(39.7)	.125(3.2)	1.515(38.5)
23	1.458(37.0)	1.375(34.9)	1.688(42.9)	.156(4.0)	1.640(41.7)
25	1.583(40.2)	1.500(38.1)	1.812(46.0)	.156(4.0)	1.765(44.8)

APPLICATION NOTES

- Assembly identified with manufacturer's name and part number, space permitting
 - Material/finish:
 Shells and nuts—Al alloy, 6061-T6, QQ-A-225/8/cadmium O.D. per QQ-P-416 Type II, Class 3 over electroless nickel, Mil-C-26074, Class 1/2/3/4, Grade A/B/C, 500 hr. salt spray
 Contacts—lead nickel copper/gold plate, MIL-G-45204, Type II
 - Metric Dimensions (mm) are indicated in parentheses.
- Class I
 Bayonet pins—AISI 300 series stainless steel/passivate, QQ-P-35
 Hoods—AISI 305 series stainless steel/passivate, QQ-P-35.
 Inserts—Epiall 1908
 Seals—silicone per ZZ-R-765

232-103-H7 Jam Nut Mount Hermetic Bulkhead Feed-Thru MIL-DTL-38999 Series II Type



Bulkhead
Feed-Thru

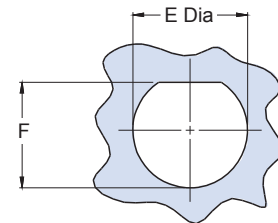
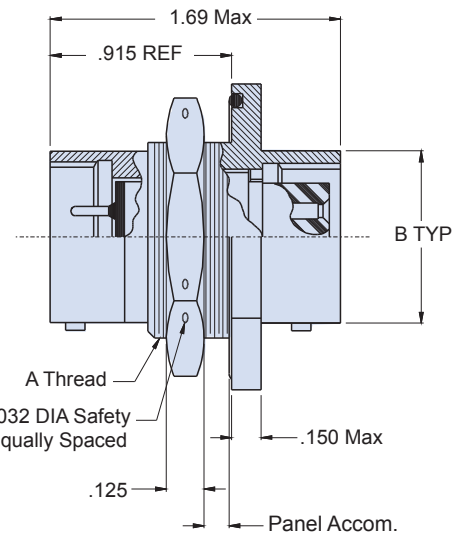
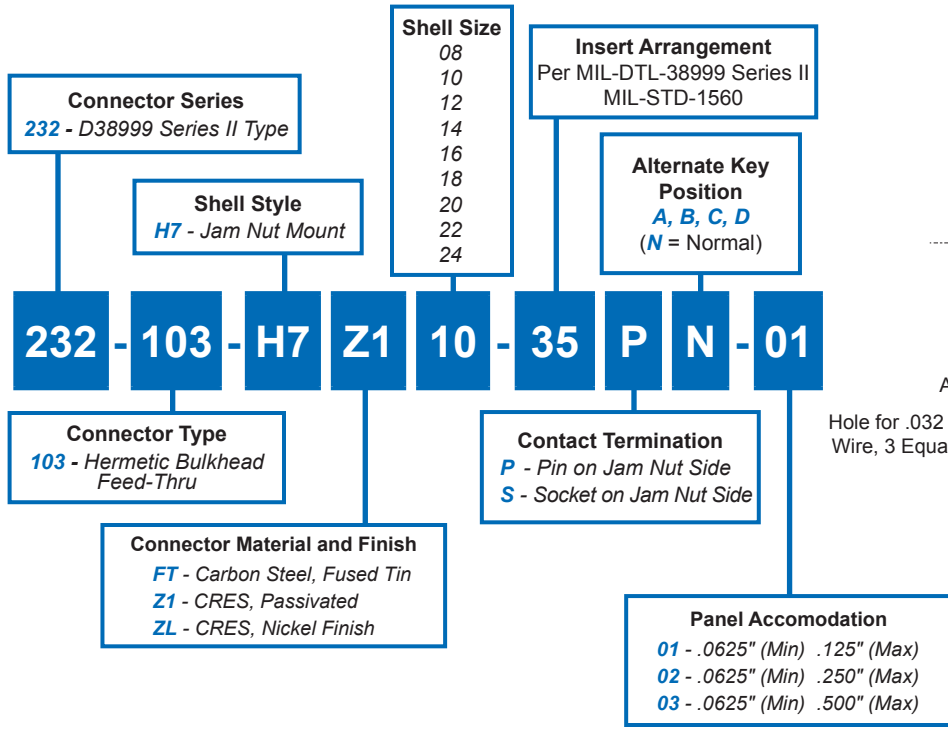

Recommended Panel Cut-Out

TABLE I: CONNECTOR DIMENSIONS

SHELL SIZE	A THREAD CLASS 2A	B DIA MAX	C HEX	D FLATS	E DIA ±.005(0.1)	F +.000-.005 (0-0.1)
08	.875-20 UNEF	.474(12.0)	1.062(27.0)	1.250(31.8)	.885(22.5)	.830(21.1)
10	1.000-20 UNEF	.591(15.0)	1.188(30.2)	1.375(34.9)	1.010(25.7)	.955(24.3)
12	1.125-18 UNEF	.751(19.1)	1.312(33.3)	1.500(38.1)	1.135(28.8)	1.085(27.6)
14	1.250-18 UNEF	.876(22.3)	1.438(36.5)	1.625(41.3)	1.260(32.0)	1.210(30.7)
16	1.375-18 UNEF	1.001(25.4)	1.562(39.7)	1.781(45.2)	1.385(35.2)	1.335(33.9)
18	1.500-18 UNEF	1.126(28.6)	1.688(42.9)	1.890(48.0)	1.510(38.4)	1.460(37.1)
20	1.625-18 UNEF	1.251(31.8)	1.812(46.0)	2.016(51.2)	1.635(41.5)	1.585(40.3)
22	1.750-18 UNS	1.376(35.0)	2.000(50.8)	2.140(54.4)	1.760(44.7)	1.710(43.4)
24	1.875-16 UN	1.501(38.1)	2.125(54.0)	2.265(57.5)	1.885(47.9)	1.835(46.6)

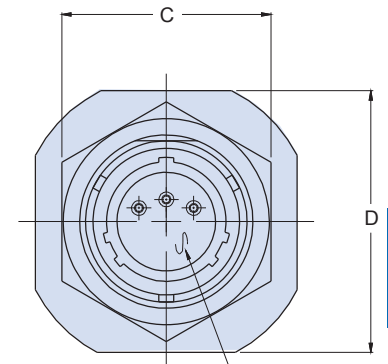

Insert Arrangement per MIL-DTL-38999, Series II MIL-STD-1560

APPLICATION NOTES

- Power to a given contact on one end will result in power to contact directly opposite, regardless of identification letter.
- Hermeticity = less than 1×10^{-4} cc/sec at one atmosphere. Not for use in liquid atmosphere.
- Material/finish:
Shell, nut – CRES/passivated, carbon steel/fused tin or CRES/nickel per QQ-N-290.
- Contacts – Gold Plated. Pin: alloy 52; Skt.: copper alloy
Insulator – fused vitreous glass/N.A.
Seals – fluorosilicone rubber/N.A.



232-104-00 Wall Mount Environmental Bulkhead Feed-Thru MIL-DTL-38999 Series II Type

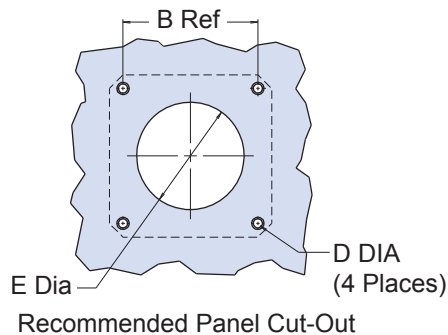
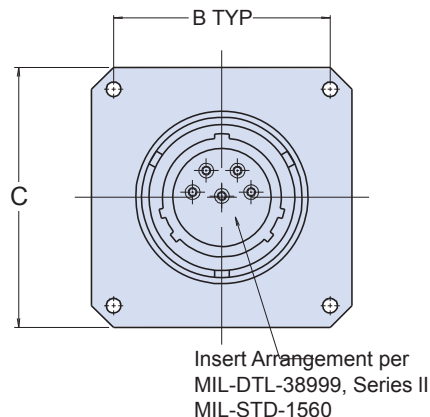
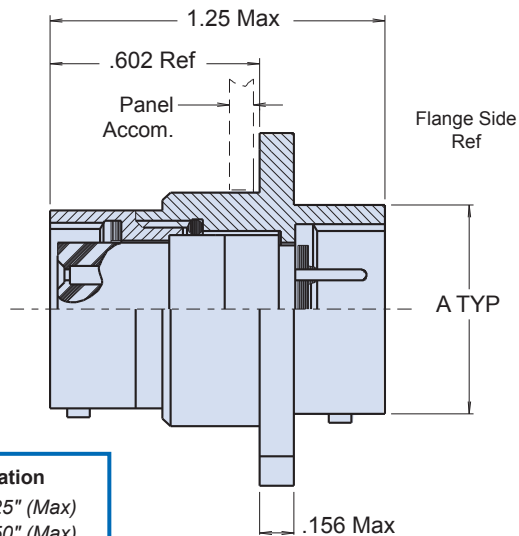
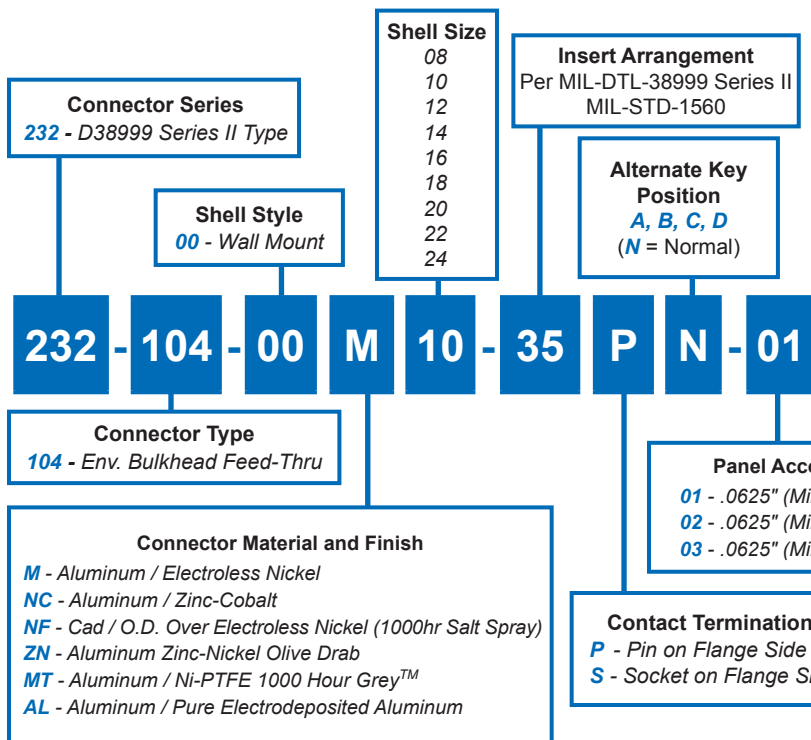

TABLE I: CONNECTOR DIMENSIONS

SHELL SIZE	A MAX	B SQ	C SQ	D DIA	E ±.005(0.1)
08	.474(12.0)	.594(15.1)	.818(20.8)	.125(3.2)	.580(14.7)
10	.591(15.0)	.719(18.3)	.944(24.0)	.125(3.2)	.697(17.7)
12	.751(19.1)	.812(20.6)	1.037(26.3)	.125(3.2)	.885(22.5)
14	.876(22.3)	.906(23.0)	1.131(28.7)	.125(3.2)	1.010(25.7)
16	1.001(25.4)	.969(24.6)	1.224(31.1)	.125(3.2)	1.135(28.8)
18	1.126(28.6)	1.062(27.0)	1.318(33.5)	.125(3.2)	1.260(32.0)
20	1.251(31.8)	1.156(29.4)	1.443(36.7)	.125(3.2)	1.385(35.2)
22	1.376(35.0)	1.250(31.8)	1.568(39.8)	.125(3.2)	1.510(38.4)
24	1.501(38.1)	1.375(34.9)	1.693(43.0)	.156(4.0)	1.635(41.5)

APPLICATION NOTES

- Material/Finish:
Shells and nuts – Al alloy,6061-T6,QQ-A-225/8, see Table II
Contacts – Leaded nickel copper - gold plate MIL-G-45204, Type II, Class I.
Bayonet pins – AISI 300 series stainless steel/passivate, QQ-P-35
Hoods – AISI 305 series stainless steel/passivate, QQ-P -35.
Inserts –High grade rigid dielectric/N.A.
Seals – Silicone/ N.A.
- Metric Dimensions (mm) are indicated in parentheses.

Too Fat to Fly?

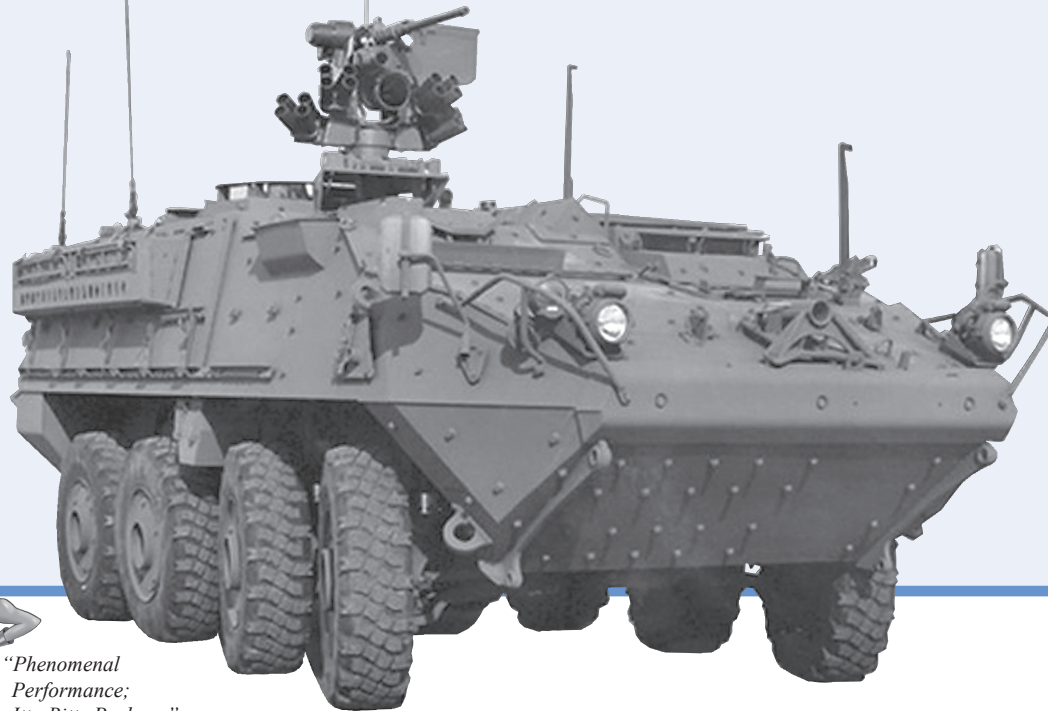

*"Phenomenal
Performance;
Itty-Bitty Package"*

Maybe. But Not Too Big To Be Saved by a Mouse.

One of the biggest challenges facing designers of armored vehicles and other rapid deployment combat platforms is the requirement to build systems which are transportable by air. In critical weight-reduction applications such as these, literally every ounce counts. That's why Glenair invented the Series 80 "Mighty Mouse;" an ultraminiature connector with

all the performance characteristics of standard Mil-Spec products. The "Mighty Mouse" is being used in ground, air and sea applications where extreme levels of weight reduction are not just an option but a necessity. So, if your system is too fat to fly, consider a switch to the mouse. The Glenair "Mighty Mouse": Phenomenal Performance, Itty-Bitty Package.



1211 Air Way

Glendale, California 91201-2497

Telephone: 818-247-6000 · Facsimilie: 818-500-9912 · EMail: sales@glenair.com

United States • United Kingdom • Germany • Niordic • France • Italy • Spain • Japan

www.glenair.com



233-103-H7 Jam Nut Mount Hermetic Bulkhead Feed-Thru MIL-DTL-38999 Series III Type

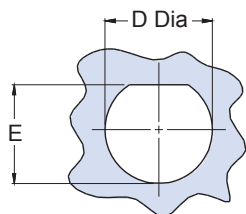
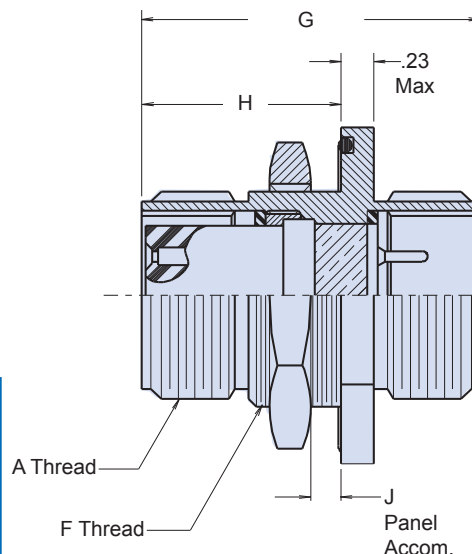
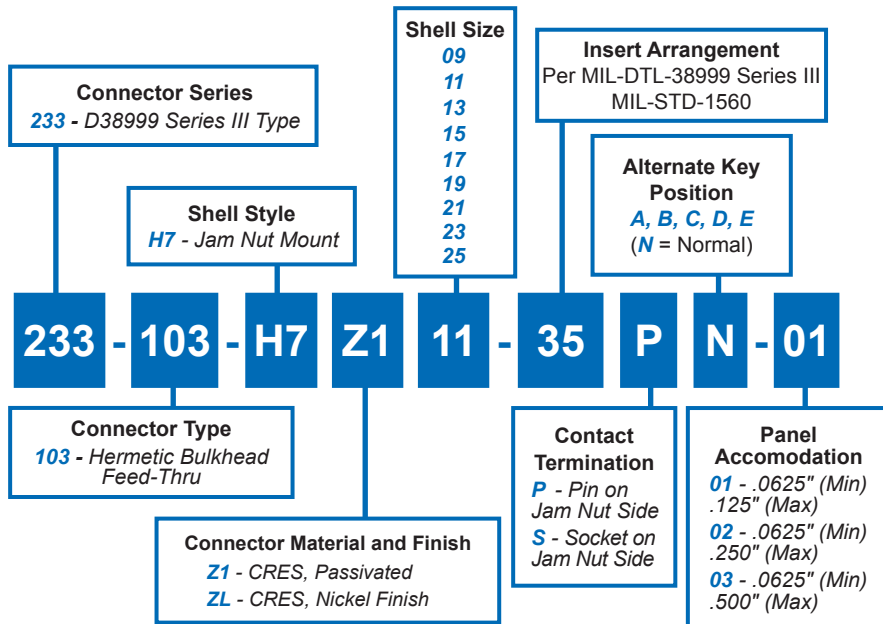

Recommended Panel Cut-Out

HERMETIC LEAK RATE MOD CODES	
Designator	Required Leak Rate
-585A	1 x 10 ⁻¹⁰ cc Helium per second
-585B	1 x 10 ⁻⁹ cc Helium per second
-585C	1 x 10 ⁻⁸ cc Helium per second

TABLE I: CONNECTOR DIMENSIONS

	G Dim, OAL	H Dim, Max	J Dim, Panel
-01	1.650 (41.91) Max	.889 (22.58)	.125 (3.18) .062 (1.57)
-02	.7500	1.375 (34.93)	.250 (6.35) .062 (1.57)
-03	.8750	1.500 (38.10)	.500 (12.7) .062 (1.57)

TABLE II: CONNECTOR DIMENSIONS

SHELL SIZE	A THREAD 0.1 P-0.3L-TS-2	B DIA	C	D DIA	E DIM	F THREAD METRIC
09	.6250	1.189 (30.20)	1.063 (27.00)	.703 (17.86) .693 (17.60)	.657 (16.69) .655 (16.64)	M17 x 1.0-6g
11	.7500	1.375 (34.93)	1.252 (31.80)	.835 (21.21) .825 (20.96)	.771 (19.58) .769 (19.53)	M20 x 1.0-6g
13	.8750	1.500 (38.10)	1.374 (34.90)	1.020 (25.91) 1.010 (25.65)	.955 (24.26) .953 (24.21)	M25 x 1.0-6g
15	1.0000	1.626 (41.30)	1.500 (38.10)	1.145 (29.03) 1.135 (28.83)	1.085 (27.56) 1.083 (27.51)	M28 x 1.0-6g
17	1.1875	1.752 (44.50)	1.626 (41.30)	1.270 (32.26) 1.260 (32.00)	1.210 (30.73) 1.208 (30.68)	M32 x 1.0-6g
19	1.2500	1.937 (49.20)	1.811 (46.00)	1.395 (35.43) 1.385 (35.18)	1.335 (33.91) 1.333 (33.86)	M35 x 1.0-6g
21	1.3750	2.063 (52.40)	1.937 (49.20)	1.520 (38.61) 1.510 (38.35)	1.460 (37.08) 1.558 (39.57)	M38 x 1.0-6g
23	1.5000	2.189 (55.60)	2.063 (52.40)	1.645 (41.78) 1.635 (41.53)	1.585 (40.26) 1.583 (40.21)	M41 x 1.0-6g
25	1.6250	2.311 (58.70)	2.189 (55.60)	1.769 (44.93) 1.759 (44.68)	1.710 (43.34) 1.708 (43.38)	M44 x 1.0-6g

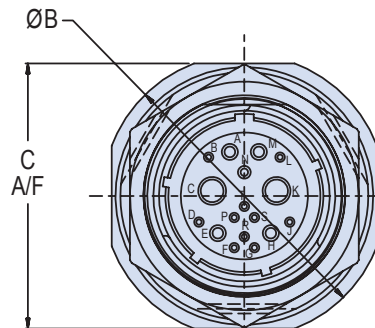

Insert Arrangement per MIL-DTL-38999 Series III MIL-STD-1560

APPLICATION NOTES

- Power to a given contact on one end will result in power to contact directly opposite, regardless of identification letter.
- Hermeticity = less than 1 x 10⁻⁷ cc/sec at one atmosphere. Not for use in liquid atmosphere.
- Material/finish:
Shell, nut – CRES/passivated, carbon steel/fused tin or CRES/nickel per QQ-N-290.
- Contacts – Gold Plated. Pin: alloy 52; Skt.: copper alloy
Insulator – fused vitreous glass/N.A.
Seals – fluorosilicone rubber/N.A.

233-104-00 Wall Mount Environmental Bulkhead Feed-Thru MIL-DTL-38999 Series III Type



Bulkhead
Feed-Thru

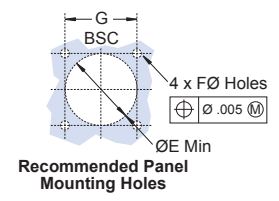
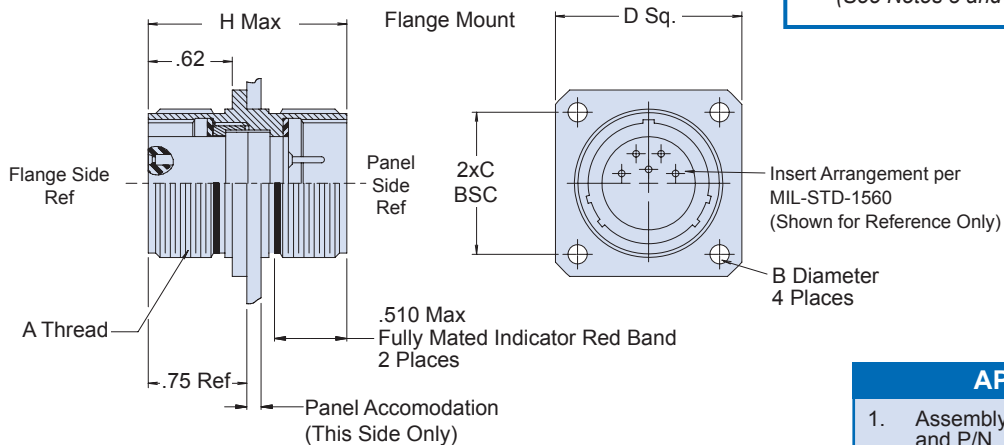
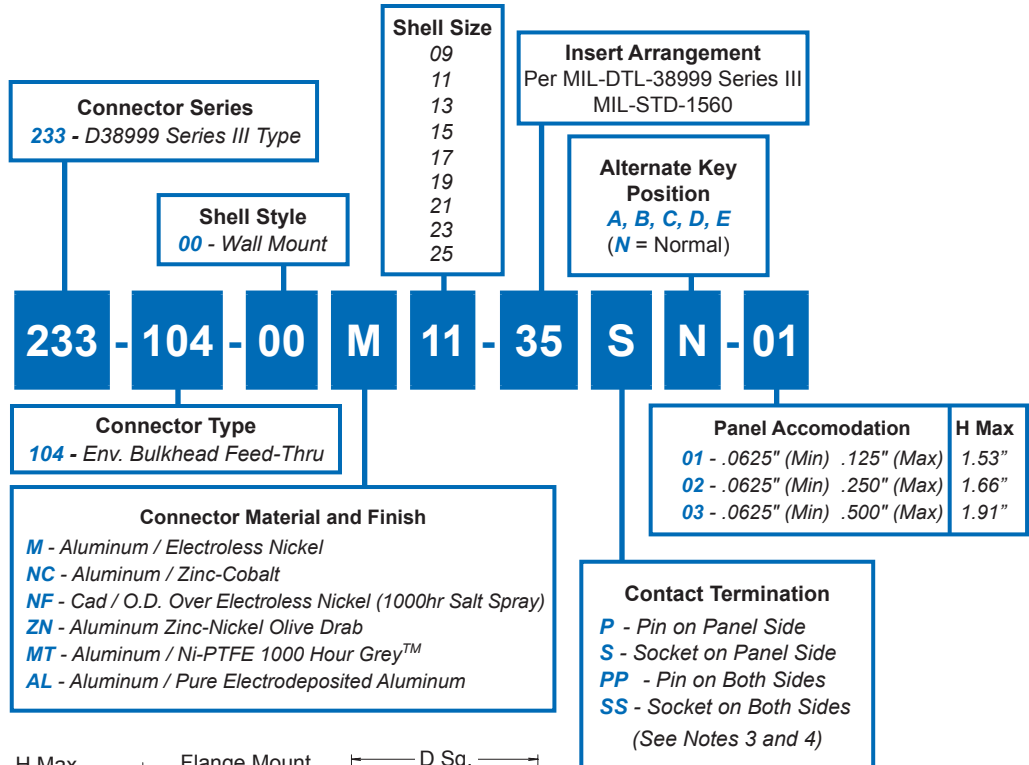

TABLE I: CONNECTOR DIMENSIONS

SHELL SIZE	A THREAD 0.1 P-0.3L-2A	B DIA. ± 0.010	C BSC	D DIM ± .020	Ø E MIN	Ø F HOLES	G BSC
09	.625	.128 (3.3)	.719 (18.3)	.938 (23.8)	.656 (16.7)	.133/.123 (3.4/3.1)	.719 (18.3)
11	.750	.128 (3.3)	.812 (20.6)	1.031 (26.2)	.796 (20.2)		.812 (20.6)
13	.875	.128 (3.3)	.906 (23.0)	1.125 (28.6)	.922 (23.4)		.906 (23.0)
15	1.000	.128 (3.3)	.969 (24.6)	1.219 (31.0)	1.047 (26.6)		.969 (24.6)
17	1.188	.128 (3.3)	1.062 (27.0)	1.312 (33.3)	1.219 (31.0)		1.062 (27.0)
19	1.250	.128 (3.3)	1.156 (29.4)	1.438 (36.5)	1.297 (32.9)		1.156 (29.4)
21	1.375	.128 (3.3)	1.250 (31.8)	1.562 (39.7)	1.422 (36.1)		1.250 (31.8)
23	1.500	.156 (4.0)	1.375 (34.9)	1.688 (42.9)	1.547 (39.3)	.156/.149 (4.0/3.8)	1.375 (34.9)
25	1.625	.156 (4.0)	1.500 (38.1)	1.812 (46.0)	1.672 (42.5)	.155/.145 (3.9/3.7)	1.500 (38.1)

- APPLICATION NOTES**
1. Assembly identified with manufacturer's name and P/N, space permitting.
 2. Material/finish:
Shell, lock ring—Al alloy, see Table II
Contacts—Copper alloy/gold plate
Insulators—High grade rigid dielectric/N.A.
Seals—Silicone/N.A.
 3. For pin/pin and skt/skt, symmetrical layout only. Consult factory for available insert arrangements.
 4. Power to a given contact on one end will result in power to contact directly opposite, regardless of identification letter.
 5. Electrical safety limits must be established by user. Peak voltage, switching surge, transient, etc., should be used to determine the safety application.
 6. Metric Dimensions (mm) are indicated in parentheses.

© 2010 Glenair, Inc. CAGE CODE 06324 Printed in U.S.A.



233-104-07 Jam Nut Mount Environmental Bulkhead Feed-Thru MIL-DTL-38999 Series III Type

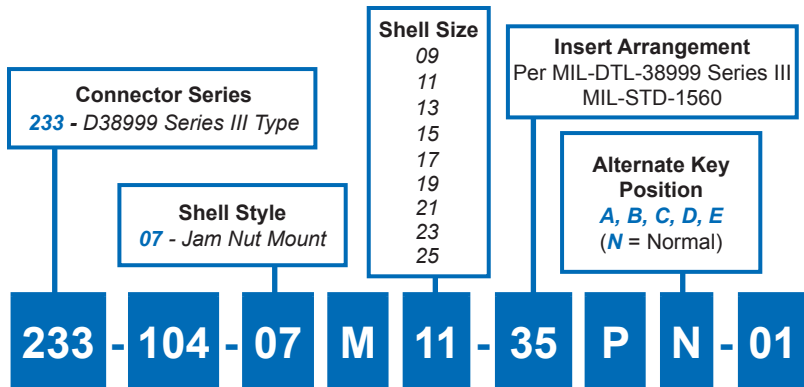

Connector Type
104 - Env. Bulkhead Feed-Thru

Connector Material and Finish

M - Aluminum / Electroless Nickel
 NC - Aluminum / Zinc-Cobalt
 NF - Cad / O.D. Over Electroless Nickel (1000hr Salt Spray)
 ZN - Aluminum Zinc-Nickel Olive Drab
 MT - Aluminum / Ni-PTFE 1000 Hour Grey™
 AL - Aluminum / Pure Electrodeposited Aluminum

Panel Accomodation

01 - .0625" (Min) .125" (Max)
 02 - .0625" (Min) .250" (Max)
 03 - .0625" (Min) .500" (Max)

Contact Termination

P - Pin on Panel Side
 S - Socket on Panel Side
 PP - Pin on Both Sides
 SS - Socket on Both Sides
 (See Notes 2 and 3)

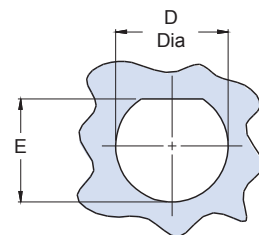
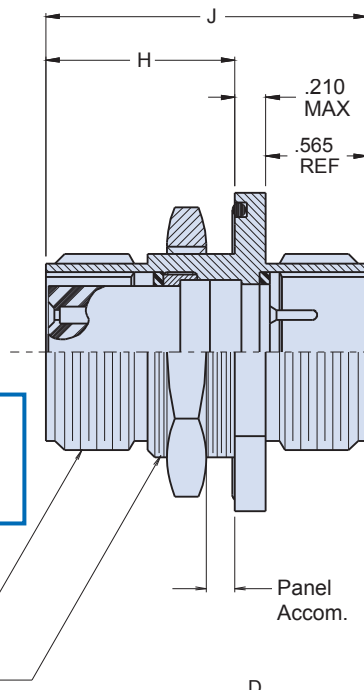

Recommended Panel Cut-Out

TABLE II: DASH NUMBERS

Dash No.	J Max	H Max
01	1.600 (40.6)	0.900 (22.9)
02	1.730 (43.9)	1.020 (25.9)
03	1.980 (50.3)	1.270 (32.3)

Insert Arrangements per MIL-DTL-38999 Series III MIL-STD-1560

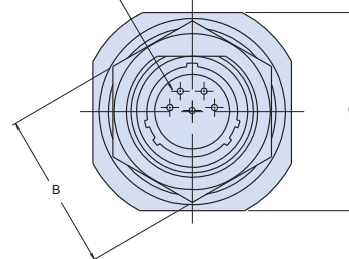

TABLE I: CONNECTOR DIMENSIONS

SHELL SIZE	A THREAD 0.1 P-0.3L-TS-2	B DIM	C DIM MAX	ØD +.005	E DIM +.000/-.002	F THREAD CLASS 2A
9	.6875	.875 (22.2)	1.090 (27.7)	.698 (17.7)	.656 (16.7)	11/16-24 UNEF
11	.7500	1.000 (25.4)	1.280 (32.5)	.830 (21.1)	.770 (19.6)	13/16-20 UNEF
13	.8750	1.250 (31.8)	1.400 (35.6)	1.015 (25.8)	.954 (24.2)	1-20 UNEF
15	1.0000	1.375 (34.9)	1.530 (38.9)	1.140 (29.0)	1.084 (27.5)	1 1/8-18 UNEF
17	1.1875	1.500 (38.1)	1.660 (42.2)	1.265 (32.1)	1.207 (30.7)	1 1/4-18 UNEF
19	1.2500	1.625 (41.3)	1.840 (46.7)	1.390 (35.3)	1.334 (33.9)	1 3/8-18 UNEF
21	1.3750	1.750 (44.5)	1.970 (50.5)	1.515 (38.5)	1.459 (40.4)	1 1/2-18 UNEF
23	1.5000	1.875 (47.6)	2.090 (53.1)	1.640 (41.7)	1.584 (40.2)	1 5/8-18 UNEF
25	1.6250	2.000 (50.8)	2.210 (56.1)	1.765 (44.8)	1.709 (43.4)	1 3/4-18 UNS

APPLICATION NOTES

- Assembly identified with manufacturer's name and P/N, space permitting.
- For pin/pin and skt/skt, symmetrical layout only. Consult factory for available insert arrangements.
- Power to a given contact on one end will result in power to contact directly opposite, regardless of identification letter.
- Electrical safety limits must be established by user. Peak voltage, switching surge, transient, etc., should be used to determine the safety application.
- Material/finish:
 Shell, lock ring—Al alloy, see Table II
 Contacts—Copper alloy/gold plate
 Insulators—High grade rigid dielectric/N.A.
 Seals—Silicone/N.A.
- Metric Dimensions (mm) are indicated in parentheses.

233-103-H9 Jam Nut Mount Hermetic Plug/Receptacle Bulkhead Feed-Thru for MIL-DTL-38999 Series III Type



Bulkhead
Feed-Thru

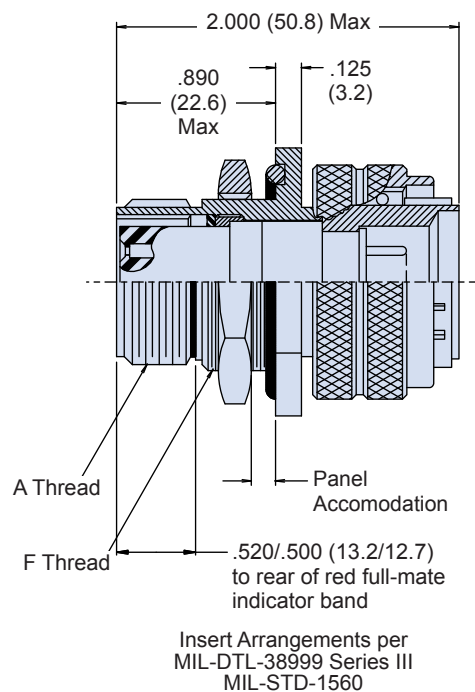
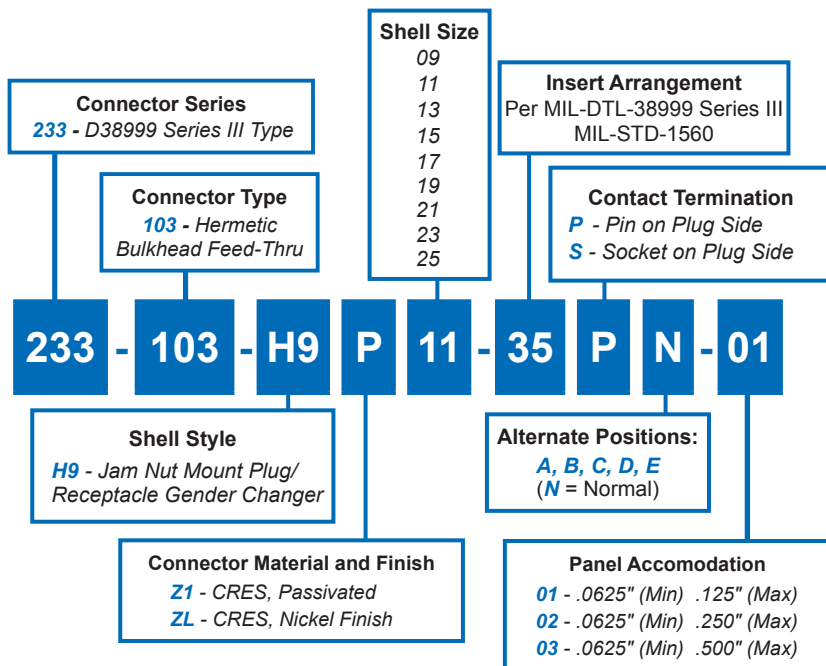
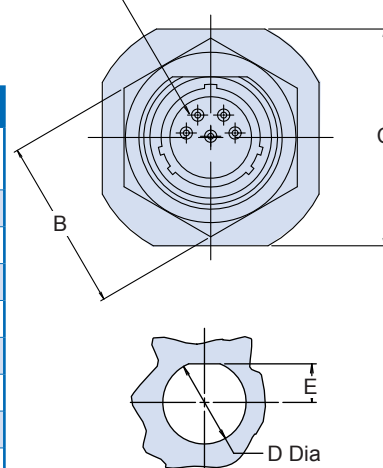

TABLE I: CONNECTOR DIMENSIONS

SHELL SIZE	A THREAD 0.1 P-0.3L-TS-2	B DIM	C DIM MAX	D DIA	E DIM	F THREAD x1-6g-0.100R
9	.6250	.945(24.0)	1.090(27.7)	.698(17.7)	.322(8.9)	M17
11	.7500	1.063(27.0)	1.280(32.5)	.822(20.9)	.385(9.8)	M20
13	.8750	1.260(32.0)	1.400(35.6)	1.010(27.6)	.479(12.3)	M25
15	1.0000	1.417(36.0)	1.530(38.9)	1.135(28.8)	.541(13.7)	M28
17	1.1875	1.457(37.0)	1.660(42.2)	1.260(32.0)	.604(15.3)	M32
19	1.2500	1.614(41.0)	1.840(46.7)	1.385(35.2)	.635(16.1)	M35
21	1.3750	1.811(46.0)	1.970(50.5)	1.510(38.4)	.698(17.7)	M38
23	1.5000	1.968(50.0)	2.090(53.1)	1.635(41.5)	.760(19.3)	M41
25	1.6250	2.017(51.2)	2.210(56.1)	1.760(44.7)	.822(20.9)	M44



Recommended
Panel Cut-Out

APPLICATION NOTES

- Power to a given contact on one end will result in power to contact directly opposite, regardless of identification letter.
 - Hermeticity = less than 1×10^{-7} cc/sec at one atmosphere. Not for use in liquid atmosphere.
 - Material/finish:
Shell, nut – CRES/passivated, carbon steel/fused tin or CRES/nickel per QQ-N-290.
 - Contacts – Gold Plated. Pin: alloy 52; Skt.: copper alloy
Insulator – fused vitreous glass/N.A.
Seals – fluorosilicone rubber/N.A.
4. Metric dimensions (mm) are indicated in parentheses.

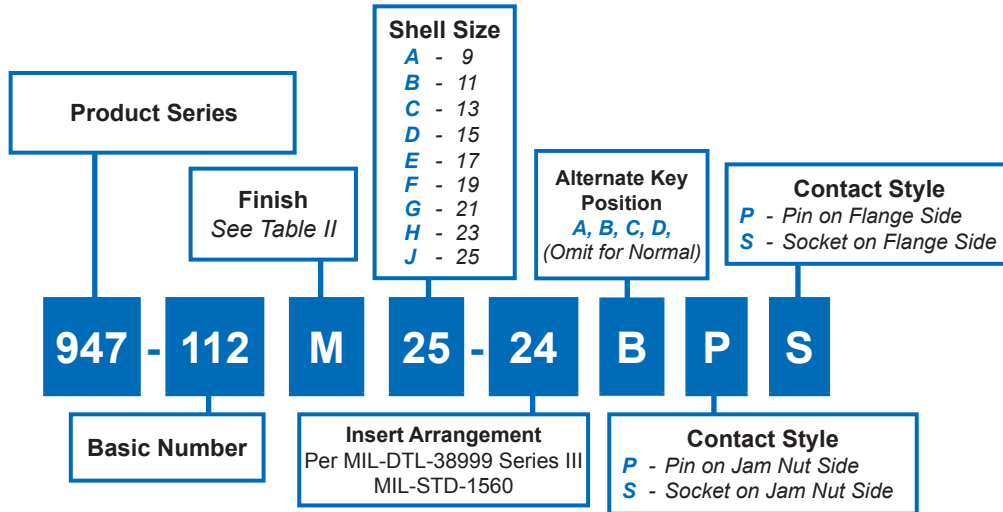

See MIL-STD-1560 for
Insert Arrangement

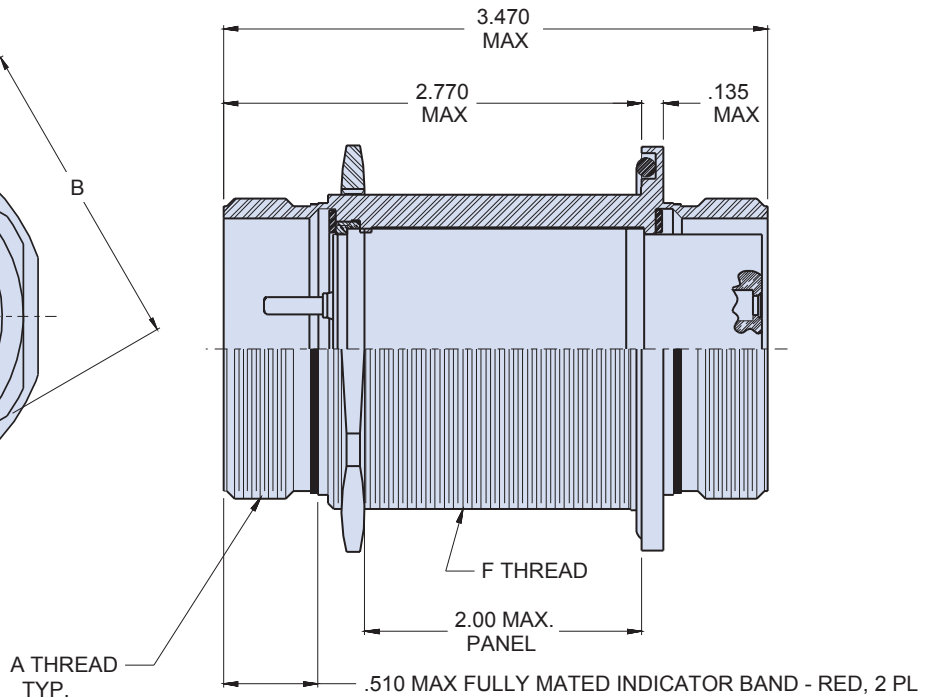
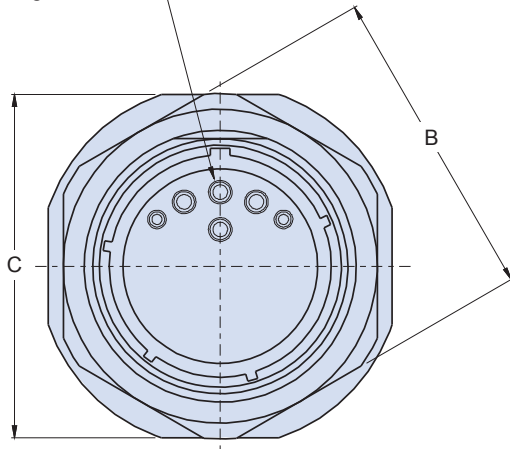

947-112
MIL-DTL-38999 Series III Type
Jam Nut Bulkhead Feed-Thru

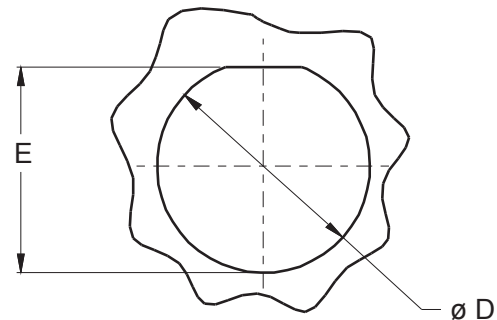

TABLE I: CONNECTOR DIMENSIONS

SHELL SIZE	A Thread 0.1P-0.3L-TS-2	B Dimension	C Dimension Max	D Diameter	E Dimension	F Thread x1-6g-0.100R
09	.6250	.875 (22.2)	1.08 (27.4)	6.98 (17.7)	.670 (17.0)	M17
11	.7500	1.000 (25.4)	1.27 (32.3)	.822 (20.9)	.771 (19.6)	M20
13	.8750	1.250 (31.8)	1.39 (35.3)	1.010 (27.6)	.995 (25.3)	M25
15	1.0000	1.375 (34.9)	1.52 (36.9)	1.135 (28.8)	1.085 (27.6)	M28
17	1.1875	1.500 (38.1)	1.64 (41.7)	1.260 (32.0)	1.210 (30.7)	M32
19	1.2500	1.625 (41.3)	1.83 (46.5)	1.385 (35.2)	1.335 (33.9)	M35
21	1.3750	1.750 (44.5)	1.95 (49.5)	1.510 (38.4)	1.460 (37.1)	M38
23	1.5000	1.875 (47.6)	2.08 (52.8)	1.635 (41.5)	1.585 (40.3)	M41
25	1.6250	2.000 (50.8)	2.20 (55.9)	1.760 (44.7)	1.710 (43.4)	M44

TABLE II: MATERIALS AND FINISH

SYM	FINISH
B	Cadmium Plate / Olive Drab
J	Gold Iridite over Cadmium Plate over Nickel
M	Electroless Nickel
N	Cadmium Plate / Olive Drab over Nickel
NF	Cadmium / Olive Drab over Electroless Nickel Nickel (500 Hour Salt Spray)
T	Cadmium Plate / Bright Dip Over Nickel



RECOMMENED PANEL CUT-OUT

APPLICATION NOTES

1. Assembly identified with manufacturers name and part number
2. Electrical safety limits must be established by user, peak voltage, switching surge, transient, etc. should be used to determine the safety applications.
3. Material/ Finishes:
Shells, Jam Nut - AL Alloy
Insulators- High Grade Rigid Dielectric/ N.A
Seals- Fluorosilicone/ N.A.

Glenair MIL-DTL-38999 Type Sav-Con[®] Connector Savers

SECTION G TABLE OF CONTENTS

GLENAIR MIL-DTL-38999 TYPE CONNECTOR SAVERS:

Glenair MIL-DTL-38999 Type Sav-Con [®] Connector Saver Product Features.....	G-1
Sav-Con [®] Connector Saver Lock Ring Selection and Use.....	G-2
MIL-DTL-38999 Sav-Con [®] Material and Finish Specifications.....	G-3
942-003 Series I Type Sav-Con [®] Plug/Receptacle Connector Saver.....	G-4
GC443 Series I Type Sav-Con [®] Plug/Plug In-Line Connector Saver.....	G-6
942-004 Series II Type Sav-Con [®] Plug/Receptacle Connector Saver.....	G-8
942-005 Series III Type Sav-Con [®] Plug/Receptacle Connector Saver.....	G-10
947-221 Series III Type Sav-Con [®] Plug/Plug In-Line Connector Saver.....	G-12
947-139 Series III Type Sav-Con [®] Pin/Pin or Socket/Socket In-Line Connector Saver.....	G-14
942-021 Series III Type Sav-Con [®] MIL-STD-1760 Connector Saver.....	G-16

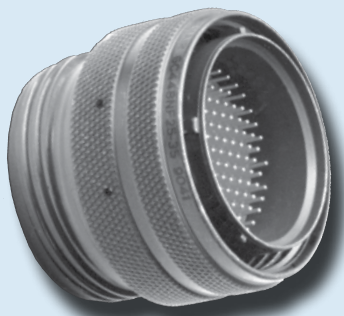

The Smart Solution for Preventing Contact Damage and Extending the Service Life of Cable Assemblies

Product Applications

Glenair Sav-Con® Connector Savers are designed to protect connectors that are subject to repeated mating and unmating cycles. Sav-Con® Connector Savers prevent costly repair or replacement of expensive connectors and cables while preserving the quality and integrity of connector performance. Sav-Con® Connector Savers take the abuse of repeated connection cycles instead of “black box” or other equipment connectors. Equipment connectors that are mated and unmated frequently during manufacturing, check-out phases and environmental test

design adds resistance to a circuit equal to a mated pin and socket contact, thus it has little or no effect on sensitive circuits.

When a Sav-Con® Connector Saver is installed between a receptacle and a plug, the effective additional length is less than the length of an equivalent mated plug and receptacle. When using bayonet coupled Sav-Con® Connector Savers, Glenair recommends our Lock Ring design feature in applications where large cable bundles may

*For MIL-DTL-38999 Series I, II and III Connectors
All Standard Materials and Finish Platings
Environmental and Hermetic Designs Available
Gender Changers
Optional Locking Mechanism
Keyed Polarization*

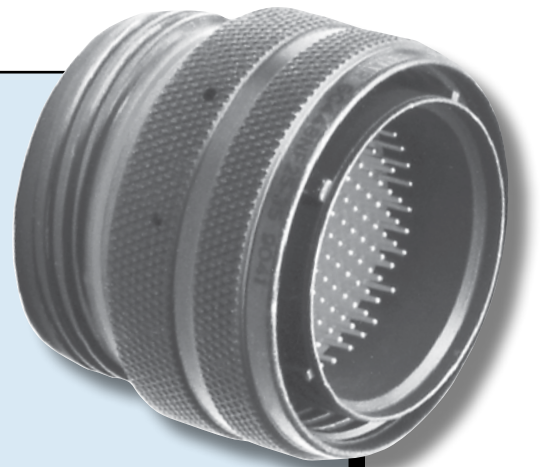

programs can be protected by Glenair Sav-Con® Connector Savers at considerable savings in time and money.

Glenair Sav-Con® Connector Savers feature one-piece, non-removable pin/socket contacts for maximum reliability and minimum effect on circuit resistance. Each Glenair Sav-Con® Connector Saver series meets the same durability requirements as the Military Specification series with which it mates. The mating portions of the pin-and-socket contacts are in strict compliance with the applicable Military Specification contacts used in each connector series. The one-piece

induce unwanted stress to the coupling mechanism and potential unwanted contact displacement (see page E-2).

Catalog contents—including part numbers, materials and dimensions—are accurate to the best of our ability when we go to print. Even so, customers are advised to consult the factory for the latest specifications, particularly to confirm critical dimensions such as connector lengths, threads, and so on. When errors or mistakes are brought to our attention, corrected content is posted immediately to our website: www.glenair.com.

Lock Ring Prevents Accidental Disengagement of Mated Connectors

For Bayonet Coupling Only

The Coupling Nut:

This feature eliminates the wave spring inside the coupling nut, thus providing positive metal-to-metal bottoming out of the plug side of the Sav-Con® Connector Saver to the mating receptacle. This is a desirable option in the following applications:

Locking a Sav-Con® to a receptacle:

Locking a Sav-Con® Connector Saver to a receptacle can prevent accidental or unauthorized unmating. This can insure that the equipment receptacle remains in its unused condition prior to delivery.

Locking a Sav-Con® to reduce lateral forces:

Lateral forces caused by a heavy cable can be reduced when the Sav-Con® Connector Saver is locked to the equipment receptacle. On high-density connectors that have a limited pin-and-socket engagement length, the force applied by a heavy cable can collapse the wave spring and create unwanted discontinuities in the mated contacts.

Locking a Sav-Con® when delivered to end-user:

When equipment is delivered to the end-user, the Sav-Con® Connector Saver may be locked to its mating receptacle to insure that the receptacles mounted on the equipment will remain unused until final installation of the equipment.

Locking a Sav-Con® to a cable mounted plug:

It is often desirable to lock a Sav-Con® Connector Saver on a cable-mounted plug coupler to prevent accidental disconnect of the Sav-Con®.

Sav-Con® Lock Ring Engagement and Disengagement Steps:

1. To engage the plug portion of the saver, first insure that the Lock Ring (2) is in the fully open position by turning the Lock Ring by hand clockwise until it stops.
2. Couple (1) to the Mating receptacle.
Note: Pins should be visible in the three holes of the Coupling Ring (1).
3. To lock the Sav-con®, turn the Lock Ring (2) counter-clockwise by hand until it stops. This will seat the bayonet pins.
4. Dis-Engagement is the reverse of steps 3 and 2. Turn Lock Ring (2) to the open position clockwise by hand until it stops. Then rotate the Coupling Ring (1) counter-clockwise until all contacts are separated.

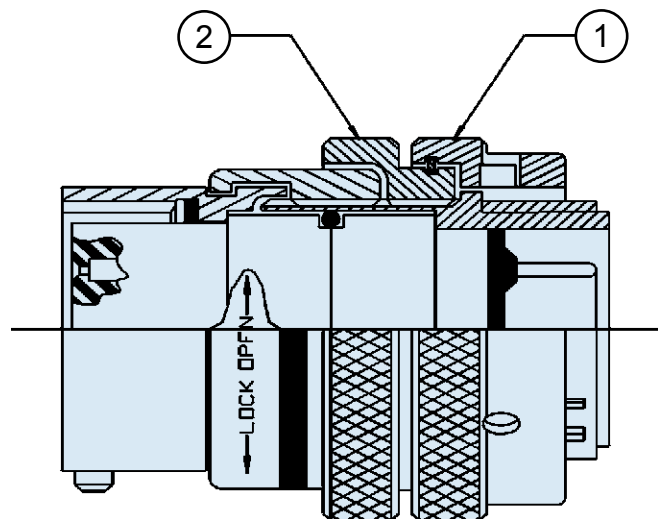

**MIL-DTL-38999 Series I, II and III
Sav-Con® Connector Saver
Material and Finish Specifications**



TABLE I: MATERIALS AND FINISHES

Shell, Barrel, and Coupling Nut (Environmental)	Aluminum alloy 6061-T6 per ASTM-B 211, 221
Front and Rear Insulators	Glass-filled liquid crystal polymer (LCP) in accordance with MIL-M-24519, Type GLP-30F
Contact Retention Clip	Beryllium copper, heat-treated, unplated
Grommet, Peripheral Seal and Interfacial Seal	Blended elastomer, 30% silicone per ZZ-R-765, 70% fluorosilicone per MIL-R-25988
Pin / Socket Contacts (Environmental)	Copper Alloy / Gold Plate
Socket Contact Hoods	Corrosion Resistant Steel IAW AISI303 Passivate QQ-P-35
Wave Spring (Bayonet Versions)	Stainless Steel 17-7PH, Condition C Passivate QQ-P-35
EMI Ground Springs	Beryllium Copper, Gold Plate MIL-G-45204
Adhesives	Silicone and epoxy
Potting Compound, PCB and Solder Cup Versions	Environmental and Hermetic Connectors: High-strength epoxy, Hysol EE4215. Filter Connectors: Stycast 2850FT/Catalyst 11 thermally conductive epoxy encapsulant.

TABLE II: MASTER SHELL FINISHES

Plating Code	Material	Finish	Specification
M	Aluminum	Electroless Nickel	AMS-C-26074
B	Aluminum	Cad Plate, Olive Drab	AMS-QQ-P-416, Type II, Class 3
NF	Aluminum	Cadmium Plate Olive Drab over Electroless Nickel	AMS-QQ-P-416, over AMS-C-26074 (1000 Hour Salt Spray)
NC	Aluminum	Zinc-Cobalt	ASTMB840
ZN	Aluminum	Olive Drab Zinc-Nickel	Zinc alloy per ASTM B841-91, Class 1 Type E Grade 3 over Electroless nickel per ASTM B733-90 SC2, Type 1 Class 5
MT	Aluminum	Ni-PTFE <i>1000 Hour Grey™</i> (Nickel Fluorocarbon Polymer)	MIL-DTL-38999L (500 Hour Salt Spray)



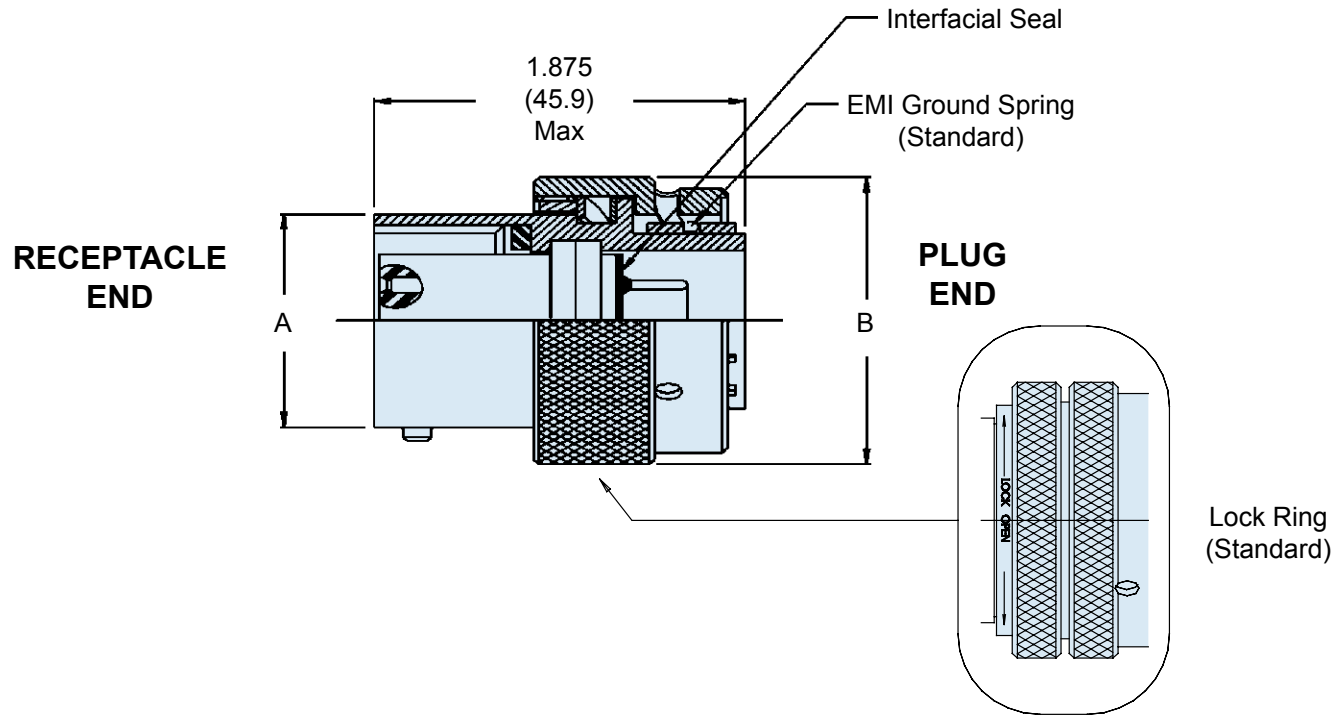
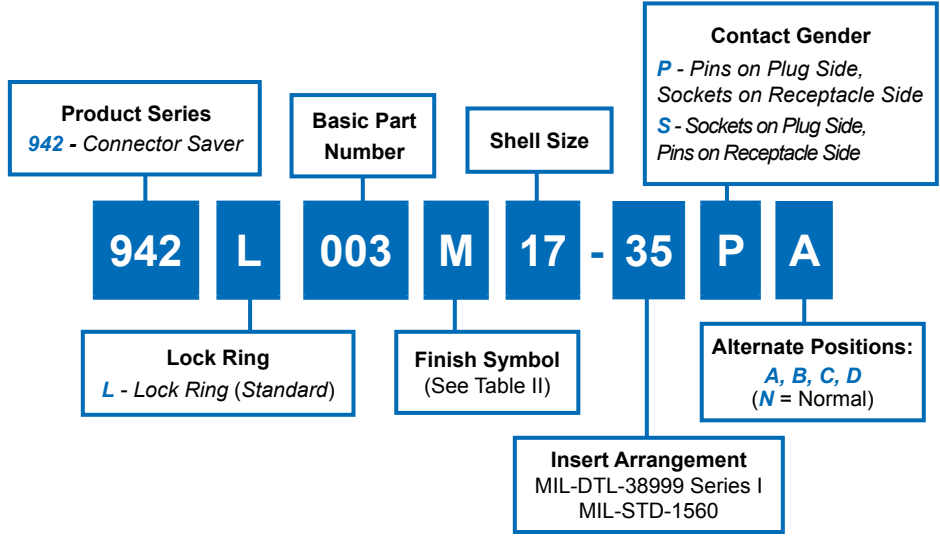

942-003
Sav-Con® Connector Saver
Plug/Receptacle
 for Use with MIL-DTL-38999 Series I

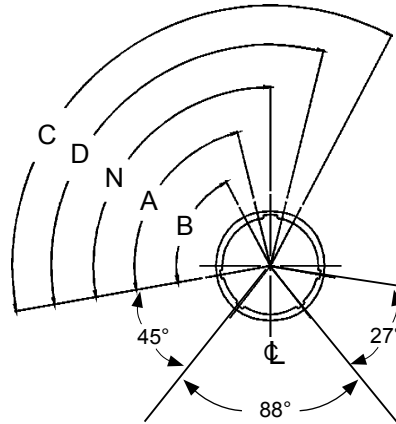

FACE VIEW
 RECEPTACLE

SERIES I: ALTERNATE KEYWAY POSITIONS					
SHELL SIZE	N°	A°	B°	C°	D°
09	95	77	--	--	113
11	95	81	67	123	109
13	95	75	63	127	115
15	95	74	61	129	116
17	95	77	85	125	113
19	95	77	65	125	113
21	95	77	65	125	113
23	95	80	69	121	110
25	95	80	69	121	110

TABLE II: SHELL FINISHES		
Plating Code	Material	Finish
M	Aluminum	Electroless Nickel
B	Aluminum	Cad Plate, Olive Drab
NF	Aluminum	Cadmium Plate Olive Drab over Electroless Nickel
NC	Aluminum	Zinc-Cobalt
ZN	Aluminum	Olive Drab Zinc-Nickel
MT	Aluminum	Ni-PTFE 1000 Hour Grey™ (Nickel Fluorocarbon Polymer)

TABLE I: CONNECTOR DIMENSIONS		
SHELL SIZE	A Max	B Diameter Max
09	.573 (14.6)	.910 (23.1)
11	.701 (17.8)	1.035 (26.3)
13	.851 (21.6)	1.210 (30.7)
15	.976 (24.8)	1.330 (33.8)
17	1.101 (28.0)	1.455 (37.0)
19	1.208 (30.7)	1.570 (39.9)
21	1.333 (33.9)	1.695 (43.1)
23	1.458 (37.0)	1.800 (45.7)
25	1.583 (40.2)	1.925 (48.9)

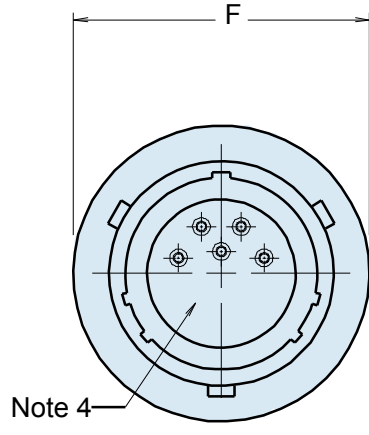
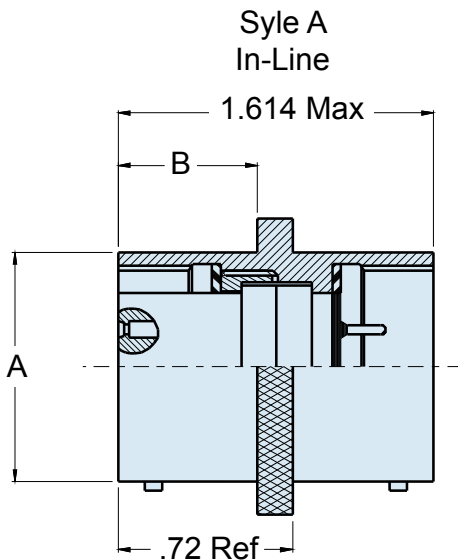
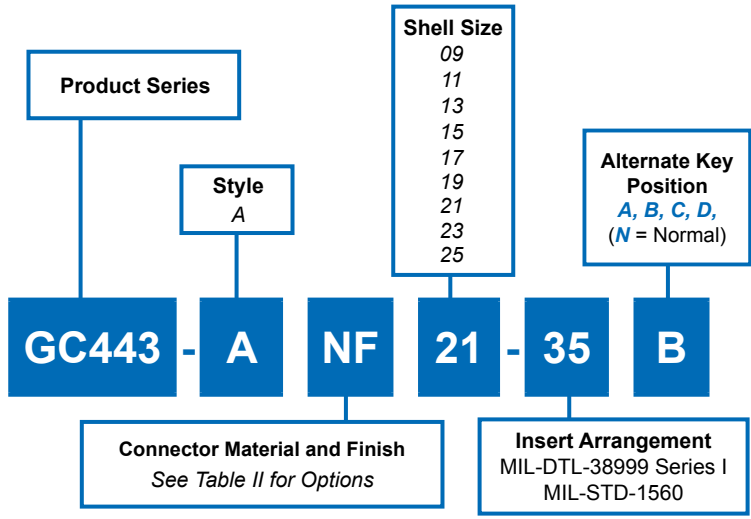

APPLICATION NOTES

- | | | |
|---|--|---|
| <ol style="list-style-type: none"> 1. Assembly identified with manufacturer's name and part number, space permitting 2. Material/finish:
Shell assembly—Al alloy/see Table II
Bayonet pins—CRES/passivate | <ol style="list-style-type: none"> 3. Metric Dimensions (mm) are indicated in parentheses 4. See MIL-DTL-38999 for Insert Arrangements | <p>Contacts—copper alloy/gold plate
Insulators—high-grade rigid dielectric/N.A.
Interfacial & peripheral seals—silicone/ N.A.</p> |
|---|--|---|

GC443
In-Line/Flange Mount Receptacle • Plug/Plug
MIL-DTL-38999 Series I Type



TABLE II: SHELL FINISHES

Plating Code	Material	Finish
M	Aluminum	Electroless Nickel
B	Aluminum	Cad Plate, Olive Drab
NF	Aluminum	Cadmium Plate Olive Drab over Electroless Nickel
NC	Aluminum	Zinc-Cobalt
ZN	Aluminum	Olive Drab Zinc-Nickel
MT	Aluminum	Ni-PTFE 1000 Hour Grey™ (Nickel Fluorocarbon Polymer)

TABLE I: CONNECTOR DIMENSIONS

SHELL SIZE	A DIA MAX	B DIA MAX	C +.010-.005 (+0.3-0.1)	D DIM	E DIM ±.020(0.5)	F DIA MAX
09	.573(14.6)	.632(16.1)	.128(3.3)	.719(18.3)	.938(23.8)	.859(21.8)
11	.701(17.8)	.632(16.1)	.128(3.3)	.812(20.6)	1.031(26.2)	.984(25.0)
13	.851(21.6)	.632(16.1)	.128(3.3)	.906(23.0)	1.125(28.6)	1.156(29.4)
15	.976(24.8)	.632(16.1)	.128(3.3)	.969(24.6)	1.219(31.0)	1.281(32.5)
17	1.101(28.0)	.632(16.1)	.128(3.3)	1.062(27.0)	1.312(33.3)	1.406(35.7)
19	1.208(30.7)	.632(16.1)	.128(3.3)	1.156(29.4)	1.438(36.5)	1.516(38.5)
21	1.333(33.9)	.602(15.3)	.147(3.7)	1.250(31.8)	1.562(39.7)	1.641(41.7)
23	1.458(37.0)	.602(15.3)	.147(3.7)	1.375(34.9)	1.688(42.9)	1.766(44.9)
25	1.583(40.2)	.602(15.3)	.147(3.7)	1.500(38.1)	1.812(46.0)	1.891(48.0)





942-004
Sav-Con® Connector Saver
Plug/Receptacle
 for Use with MIL-DTL-38999 Series II

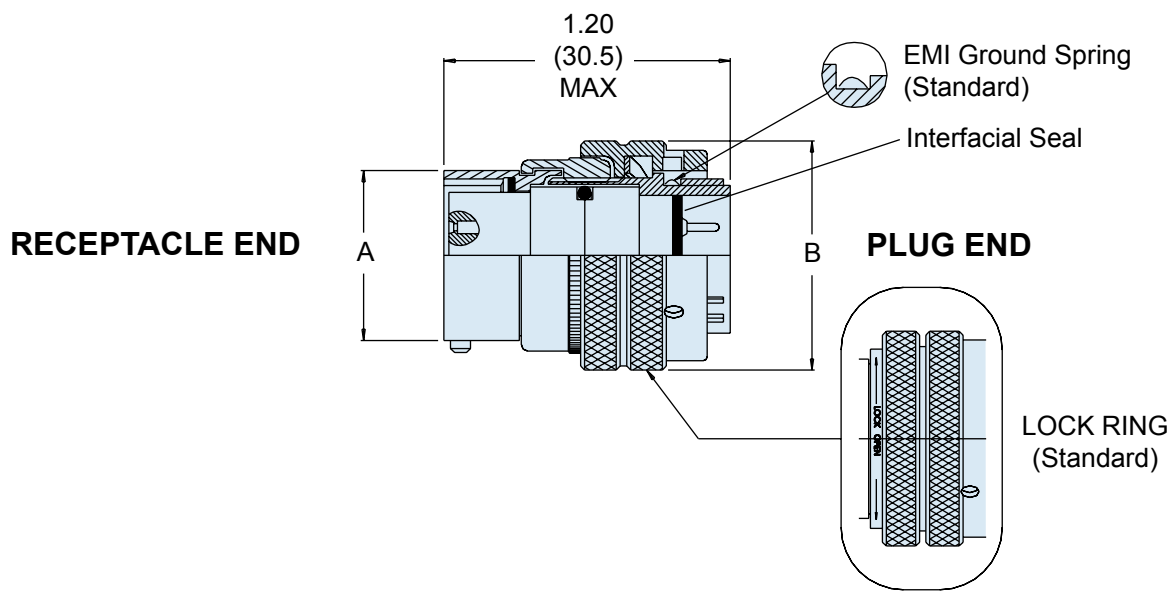
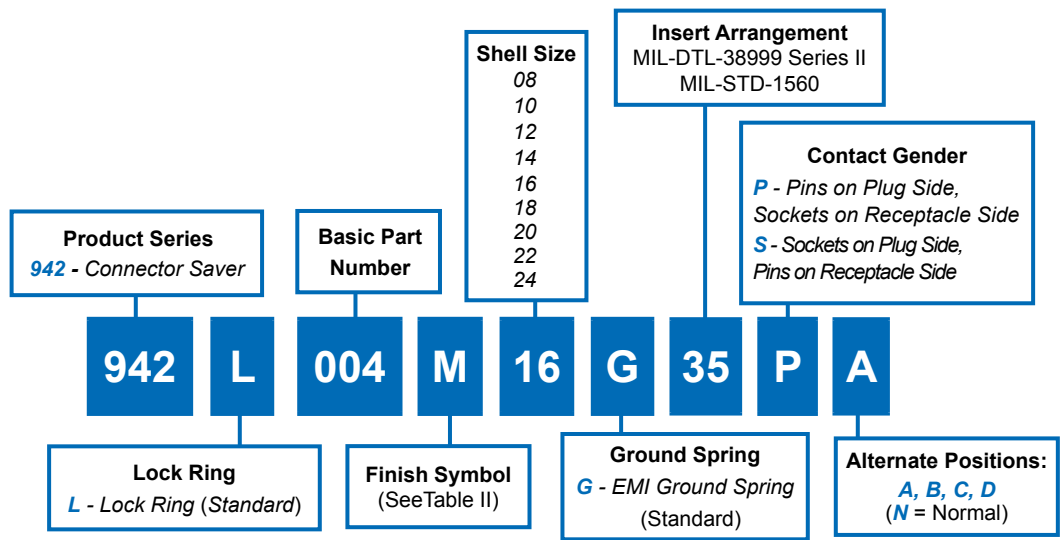

942-004
**Sav-Con® Connector Saver
 Plug/Receptacle**
 for Use with MIL-DTL-38999 Series II

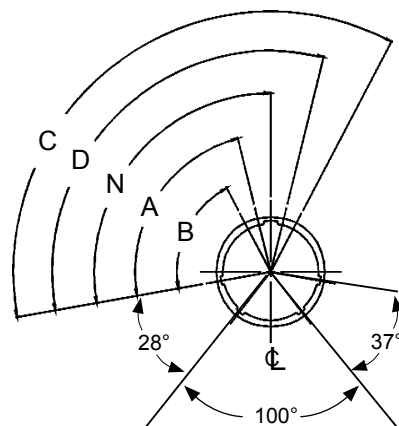

FACE VIEW
 RECEPTACLE

SERIES II: ALTERNATE KEYWAY POSITIONS

SHELL SIZE	N°	A°	B°	C°	D°
08	100	82	--	--	118
10	100	86	72	128	114
12	100	80	68	132	120
14	100	79	66	134	121
16	100	82	70	130	118
18	100	82	70	130	118
20	100	82	70	130	118
22	100	85	74	126	115
24	100	85	74	125	115

TABLE II: SHELL FINISHES

Plating Code	Material	Finish
M	Aluminum	Electroless Nickel
B	Aluminum	Cad Plate, Olive Drab
NF	Aluminum	Cadmium Plate Olive Drab over Electroless Nickel
NC	Aluminum	Zinc-Cobalt
ZN	Aluminum	Olive Drab Zinc-Nickel
MT	Aluminum	Ni-PTFE 1000 Hour Grey™ (Nickel Fluorocarbon Polymer)

TABLE I: CONNECTOR DIMENSIONS

SHELL SIZE	A MAX.	B MAX.
08	.474 (12.0)	.750 (19.1)
10	.591 (15.0)	.859 (21.8)
12	.751 (19.1)	1.031 (26.2)
14	.875 (22.2)	1.156 (29.4)
16	1.001 (25.4)	1.281 (32.5)
18	1.126 (28.6)	1.406 (35.7)
20	1.251 (31.8)	1.531 (38.9)
22	1.376 (35.0)	1.656 (42.1)
24	1.501 (38.1)	1.777 (45.1)

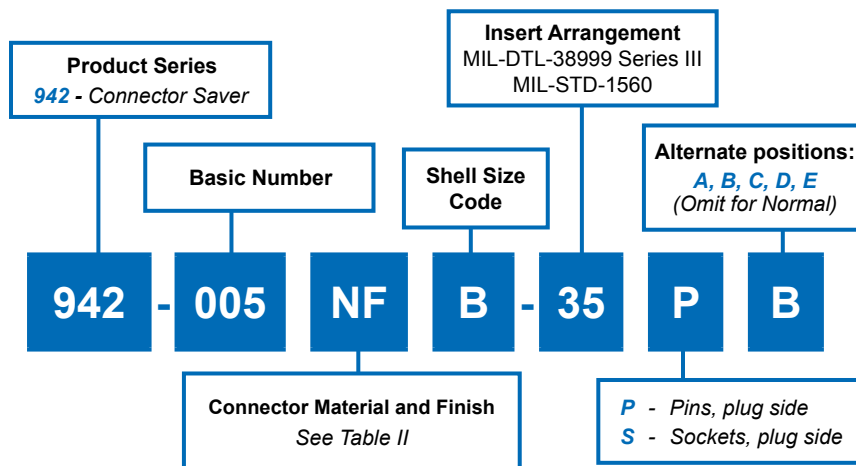
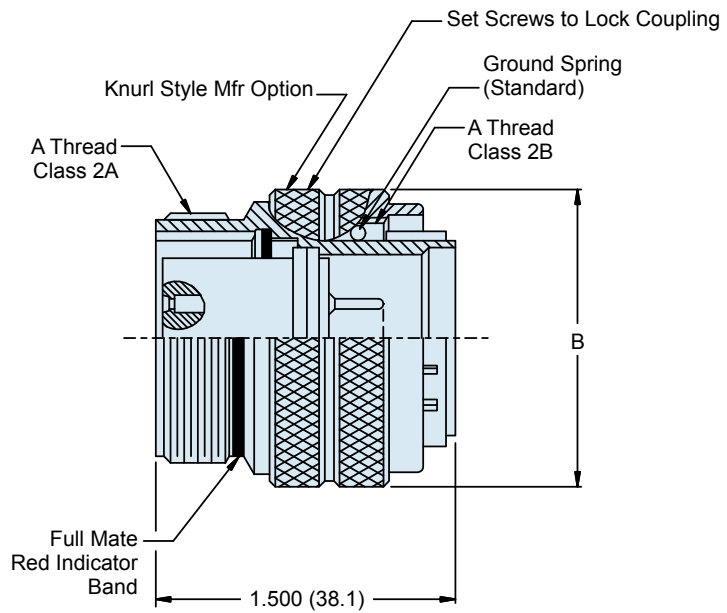

TABLE I: CONNECTOR DIMENSIONS

SHELL SIZE	SHELL SIZE CODE	A THREAD 0.1P-0.3L-TS-2	B DIA MAX
09	A	.6250	.859
11	B	.7500	.969
13	C	.8750	1.141
15	D	1.0000	1.266
17	E	1.1875	1.391
19	F	1.2500	1.500
21	G	1.3750	1.625
23	H	1.5000	1.750
25	J	1.6250	1.875



APPLICATION NOTES

- Assembly features straight-thru double ended socket contacts. Power to a given contact on one end will result in power to contact directly opposite regardless of identification.
- Metric dimensions (mm) are indicated in parentheses.
- Material/finish:
 Barrel/shell, coupling nut, lock ring—Al alloy
 Contacts, grounding ring—Copper Al alloy/gold plate
 Detent spring—Corrosion resistant material
 Retaining device—CRES/passivate
 O-ring, interfacial & peripheral seals—Fluorosilicone/N.A.
 Insulators—High grade rigid dielectric/ N.A.

942-005
Sav-Con® Connector Saver
Plug/Receptacle
 for Use with MIL-DTL-38999 Series III



TABLE II: SHELL FINISHES		
Plating Code	Material	Finish
M	Aluminum	Electroless Nickel
B	Aluminum	Cad Plate, Olive Drab
NF	Aluminum	Cadmium Plate Olive Drab over Electroless Nickel
NC	Aluminum	Zinc-Cobalt
ZN	Aluminum	Olive Drab Zinc-Nickel
MT	Aluminum	Ni-PTFE 1000 Hour Grey™ (Nickel Fluorocarbon Polymer)

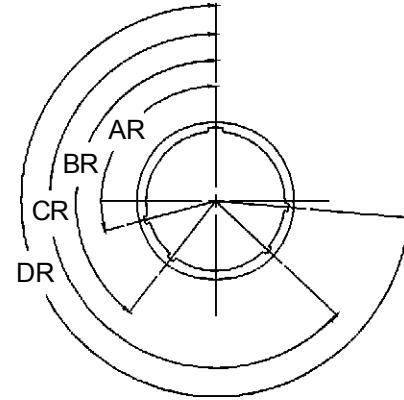

FACE VIEW
 RECEPTACLE

SERIES III: ALTERNATE KEYWAY POSITIONS						
Shell Size Code	Shell Size Ref	Alternate Keyway Code	AR°	BR°	CR°	DR°
A	09	N	105	140	215	265
		A	102	132	248	320
		B	80	118	230	312
		C	35	140	205	275
		D	64	155	234	304
		E	91	131	197	240
B C D	11 13 15	N	95	141	208	236
		A	113	156	182	292
		B	90	145	195	252
		C	53	156	220	255
		D	119	146	176	298
		E	51	141	184	242
E F	17 19	N	80	142	196	293
		A	135	170	200	310
		B	49	169	200	244
		C	66	140	200	257
		D	62	145	180	280
		E	79	153	197	272
G H J	21 23 25	N	80	142	196	293
		A	135	170	200	310
		B	49	169	200	244
		C	66	140	200	257
		D	62	145	180	280
		E	79	153	197	272



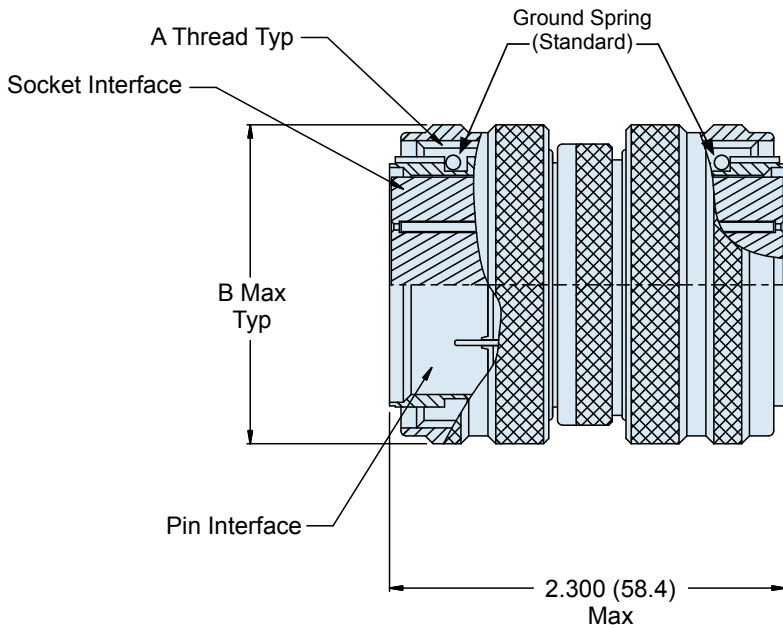
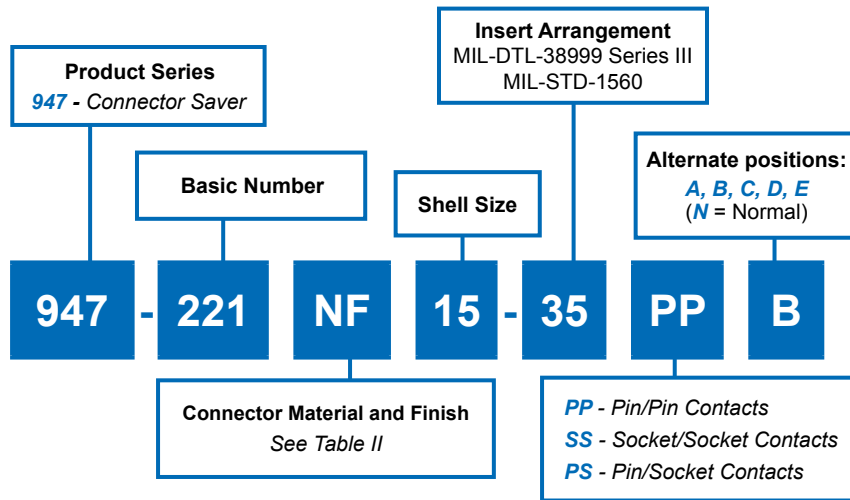

TABLE I: CONNECTOR DIMENSIONS		
SHELL SIZE	A THREAD 0.1 P-0.3L-TS-2	B DIA MAX
09	0.6250	.859(21.8)
11	0.7500	.969(24.6)
13	0.8750	1.141(29.0)
15	1.0000	1.266(32.2)
17	1.1875	1.391(35.3)
19	1.2500	1.500(38.1)
21	1.3750	1.625(41.3)
23	1.5000	1.750(44.5)
25	1.6250	1.875(47.6)

APPLICATION NOTES

1. Assembly features straight-thru double-ended contacts, power to a given contact on one end will result in power to contact directly opposite, regardless of identification.
2. Symmetrical layout only, Consult factory for available insert arrangements.
3. Metric dimensions (mm) are indicated in parentheses.
4. Material/finish:
Barrel, adapter, junction nuts, coupling nuts—Al alloy/see Table I.
Insulators—High grade rigid dielectric/N.A.
Contacts—Copper alloy/gold plate

947-221
Sav-Con® Connector Saver
Plug/Plug In-Line Connector
 for Use with MIL-DTL-38999 Series III



TABLE II: SHELL FINISHES		
Plating Code	Material	Finish
M	Aluminum	Electroless Nickel
B	Aluminum	Cad Plate, Olive Drab
NF	Aluminum	Cadmium Plate Olive Drab over Electroless Nickel
NC	Aluminum	Zinc-Cobalt
ZN	Aluminum	Olive Drab Zinc-Nickel
MT	Aluminum	Ni-PTFE 1000 Hour Grey™ (Nickel Fluorocarbon Polymer)

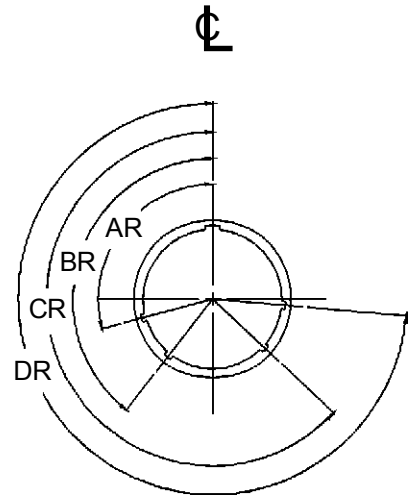

FACE VIEW
 RECEPTACLE

SERIES III: ALTERNATE KEYWAY POSITIONS						
Shell Size Code	Shell Size Ref	Alternate Keyway Code	AR°	BR°	CR°	DR°
A	09	N	105	140	215	265
		A	102	132	248	320
		B	80	118	230	312
		C	35	140	205	275
		D	64	155	234	304
B C D	11 13 15	N	95	141	208	236
		A	113	156	182	292
		B	90	145	195	252
		C	53	156	220	255
		D	119	146	176	298
E F	17 19	N	80	142	196	293
		A	135	170	200	310
		B	49	169	200	244
		C	66	140	200	257
		D	62	145	180	280
G H J	21 23 25	N	80	142	196	293
		A	135	170	200	310
		B	49	169	200	244
		C	66	140	200	257
		D	62	145	180	280
		E	79	153	197	272





947-139
Sav-Con® Connector Saver
In-Line Connector
for Use with MIL-DTL-38999 Series III

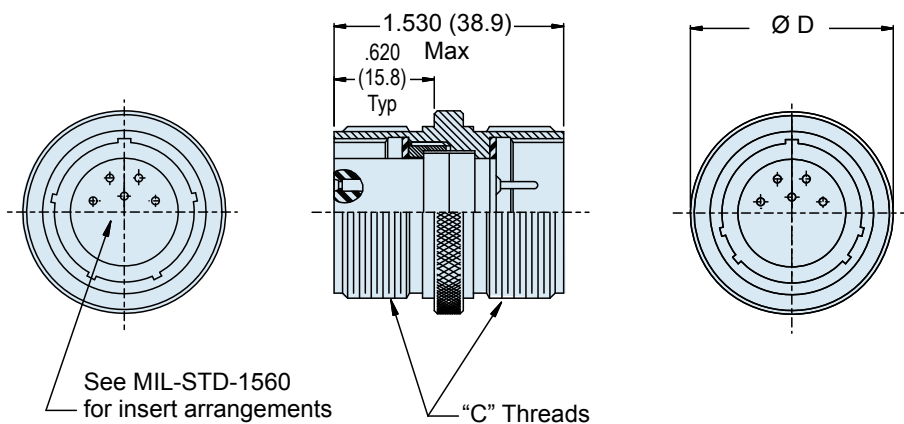
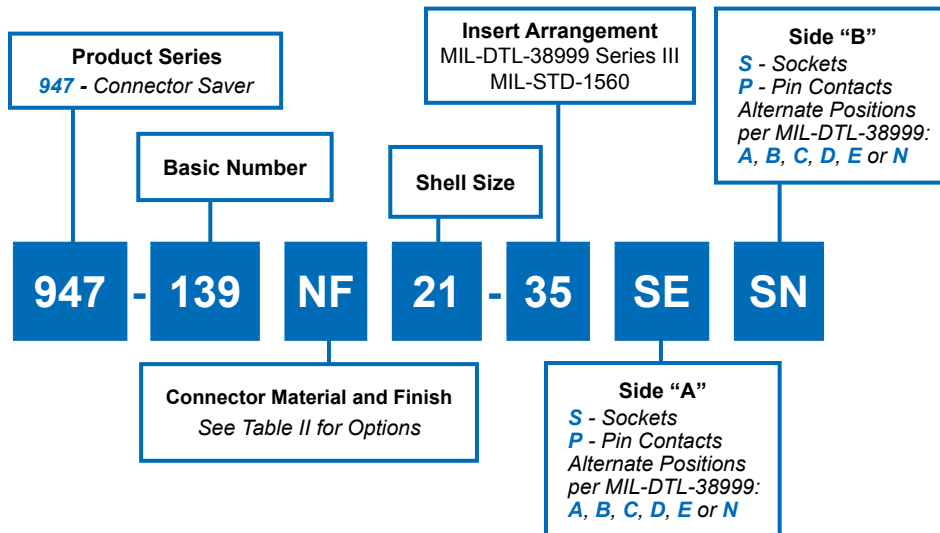

TABLE I: CONNECTOR DIMENSIONS		
SHELL SIZE	C THREAD	Ø D MAX
09	.625-1P-.3L-2A	.859
11	.750-1P-.3L-2A	.984
13	.875-1P-.3L-2A	1.156
15	1.000-1P-.3L-2A	1.281
17	1.187-1P-.3L-2A	1.406
19	1.250-1P-.3L-2A	1.516
21	1.375-1P-.3L-2A	1.641
23	1.500-1P-.3L-2A	1.766
25	1.625-1P-.3L-2A	1.891

APPLICATION NOTES

- For pin/pin and skt/skt symmetrical layouts only. Consult factory for available insert arrangements.
- Power to a given contact on one end will result in power to the contact directly opposite, regardless of identification marking.
- Metric dimensions (mm) are indicated in parentheses.
- Material/finish:
Shell assembly—Al alloy/see Table II
Contacts—Copper alloy/gold plate
Insulators—High-grade rigid dielectric/ N.A.
Seals—Silicone/ N.A

947-139
Sav-Con® Connector Saver
In-Line Connector
 for Use with MIL-DTL-38999 Series III



TABLE II: SHELL FINISHES		
Plating Code	Material	Finish
M	Aluminum	Electroless Nickel
B	Aluminum	Cad Plate, Olive Drab
NF	Aluminum	Cadmium Plate Olive Drab over Electroless Nickel
NC	Aluminum	Zinc-Cobalt
ZN	Aluminum	Olive Drab Zinc-Nickel
MT	Aluminum	Ni-PTFE 1000 Hour Grey™ (Nickel Fluorocarbon Polymer)

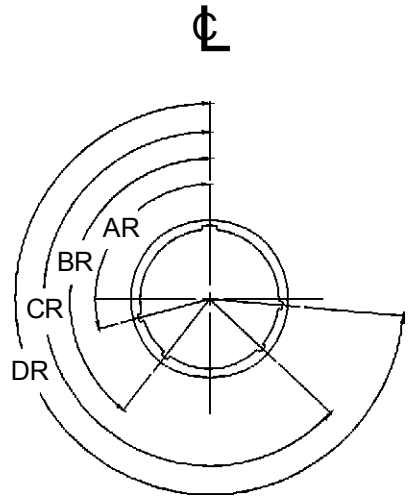

FACE VIEW
 RECEPTACLE

SERIES III: ALTERNATE KEYWAY POSITIONS						
Shell Size Code	Shell Size Ref	Alternate Keyway Code	AR°	BR°	CR°	DR°
A	09	N	105	140	215	265
		A	102	132	248	320
		B	80	118	230	312
		C	35	140	205	275
		D	64	155	234	304
B C D	11 13 15	N	95	141	208	236
		A	113	156	182	292
		B	90	145	195	252
		C	53	156	220	255
		D	119	146	176	298
E F	17 19	N	80	142	196	293
		A	135	170	200	310
		B	49	169	200	244
		C	66	140	200	257
		D	62	145	180	280
G H J	21 23 25	N	80	142	196	293
		A	135	170	200	310
		B	49	169	200	244
		C	66	140	200	257
		D	62	145	180	280
		E	79	153	197	272



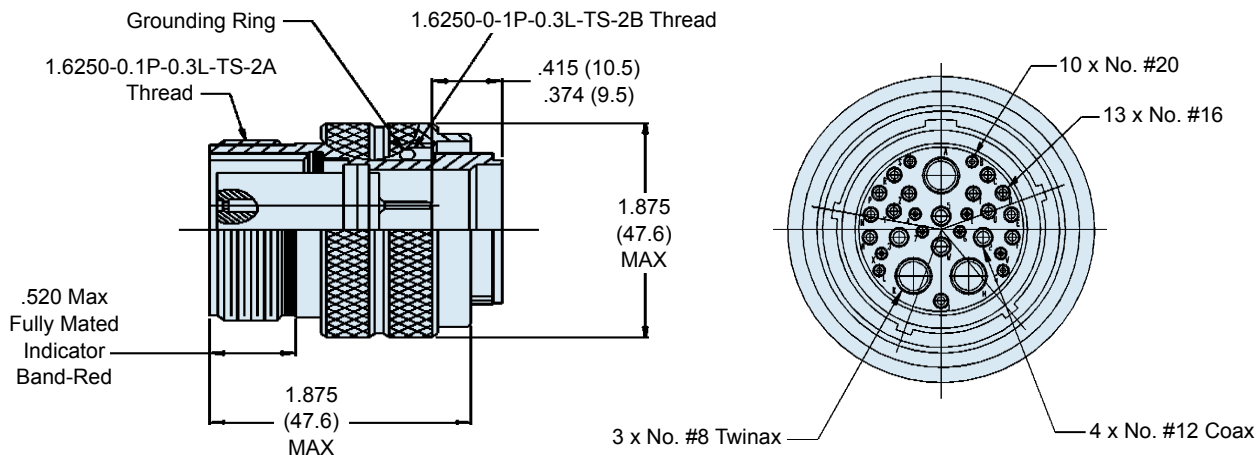
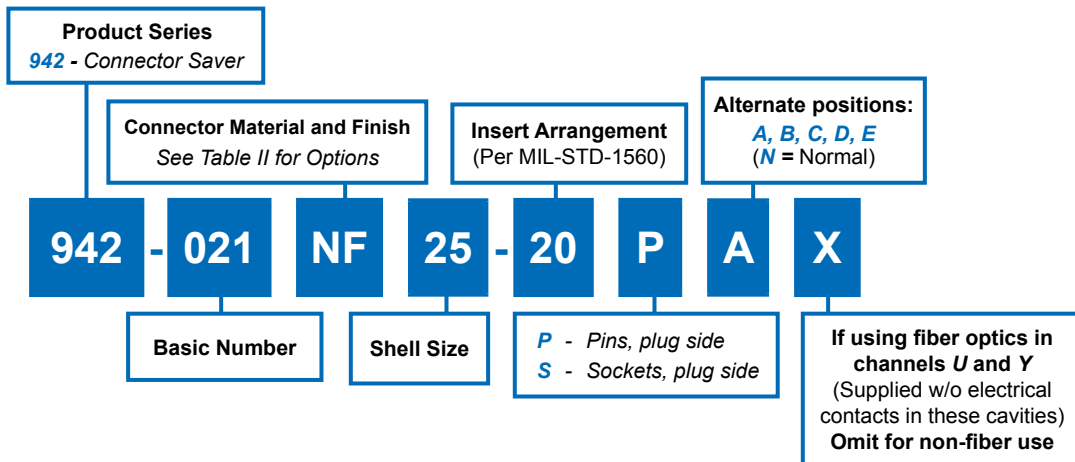

25-20 INSERT ARRANGEMENT

SHELL SIZE CODE	SHELL SIZE	INSERT ARRANGEMENT DASH NO.	TOTAL NUMBER OF CONTACTS	CONTACT SIZE			
				20	16	12 (Coax)	8 (Twinax)
J	25	25-20	30	QUANTITY			
				10	13	4	3

APPLICATION NOTES

- All set screws to have N.D. Ind. Stud grade threadlocker #140500 (jet fuel resistant).
- Metric dimensions (mm) are indicated in parentheses.
- Material/finish:
Barrel/shell, coupling nut, lock ring – CRES Passivated

Contacts – Copper alloy/gold plate
Interfacial & peripheral seals – silicone/N.A.
Insulators – High grade rigid dielectric/ N.A.
Shrink Tube – See Table I

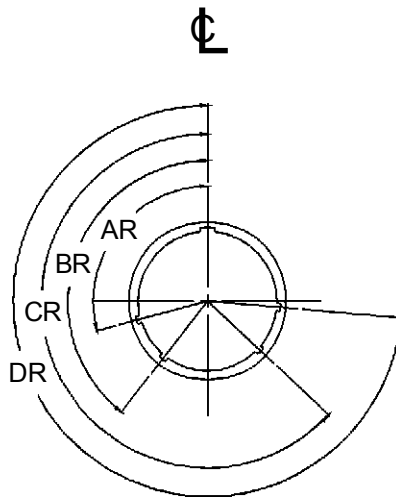

FACE VIEW
 RECEPTACLE

SERIES III: ALTERNATE KEYWAY POSITIONS						
Shell Size Code	Shell Size Ref	Alternate Keyway Code	AR°	BR°	CR°	DR°
J	25	N	80	142	196	293
		A	135	170	200	310
		B	49	169	200	244
		C	66	140	200	257
		D	62	145	180	280
		E	79	153	197	272



Glenair Connector Accessories and Tools

SECTION H TABLE OF CONTENTS

GLENAIR Connector Accessories and Tools:

Glenair Connector Accessories and Tools Product Features.....	H-1
Glenair MIL-DTL-38999 Type Backshells and Accessories Selection Guide.....	H-2
Glenair D38999 Type Backshell Interface Dimensions.....	H-4
770-001 Part Number Development and S-Straight Shrink Boot Heat Shrink Molded Part.....	H-5
770-001 A -90° Shrink Boot Heat Shrink Molded Part.....	H-6
770-001 B 45° SHrink Boot Heat Shrink Molded Part.....	H-7
310-001 O-Ring Sealed Shrink Boot Adapter.....	H-8
319-064 Composite Swing-Arm Strain Relief with Nickel/Copper EMI/RFI Shield Sock.....	G-10
319-065 Composite Swing-Arm Strain Relief with Composite EMI/RFI Shield Sock.....	G-12
Swing-Arm Assembly Instructions.....	G-14
380-107 EMI/RFI Split-Shell Non-Environmental Backshell with Strain Relief.....	G-16
380-115 EMI/RFI Low Profile Non-Environmental Backshell with Strain Relief.....	G-18
440-069 EMI/RFI Shrink Boot Banding Adapter.....	G-20
447-425 EMI/RFI Non-Environmental Band-In-A-Can Backshell with Strain-Relief.....	G-22
620-048 Strain Relief Clamp, Straight and 90°.....	G-24
620-049 Strain Relief Clamp, 45°.....	G-25
627-122 Composite Swing-Arm Strain Relief.....	G-26
687-207 Composite MIL-C-85049/93 Banding Split-Ring.....	G-28
103-026 and -027 AmberStrand® Composite EMI/RFI Braid.....	G-29
100-001 Tubular Metal Braid QQ-B-575B ASTM B33 Tin Coated Copper.....	G-30
100-003 Tubular Metal Braid ASTM B355 Class 4 OFHC Nickel Plated Copper.....	G-31
930-001 Conductive Gasket for Flange Mount Series III Receptacle Connector.....	G-32
MS85049/94 Full Perimeter Nut Plate.....	G-34
MS85049/95 3/4 Perimeter Nut Plate.....	G-35
MS85049/96 1/4 Perimeter Nut Plate.....	G-36
650FS001 Series I Dummy Stowage Receptacle.....	G-38
650FS002 Series II Dummy Stowage Receptacle.....	G-39
650HS010 Series III Dummy Stowage Receptacle.....	G-40
650HS007 Dummy Stowage Receptacle for MIL-DTL-38999 Series IV Connectors.....	G-41
660-012 (Plug), 660-013 (Receptacle), 661-002 (EMI Receptacle) Series I Protective Covers.....	G-42
660-014 (Plug), 660-015 (Receptacle), 661-003 (EMI Receptacle) Series II Protective Covers.....	G-44
60-023 (Plug), 660-024 (Receptacle) Series III Protective Covers.....	G-46
60-031 (Plug), 660-032 (Receptacle) Series IV Protective Covers.....	G-48
TG70 Strap Wrench with 3/8" Square Drive.....	G-50
<i>BAND-IT</i> ® Shield Termination Clamping System.....	G-51 - G-53
600-004 and 600-007 Bench Mount and Hand Held Torque Wrenches.....	G-54
600-161 Hand Held Digital Torque Wrench and 600-162 Bench Stand.....	G-55
MIL-DTL-38999 Series I, II, III and IV Connector Holding Tools.....	G-56 - G-62
600-091 and 600-157 Composite Hex Coupling Wrench.....	G-63 - G-64

Because the Art of Interconnect Cable Design Calls for More Technology Than Just a Connector

Backshells: A Part of Every Well-Designed Cable Harness and Assembly

Glenair understands that the management of EMI, environmental damage and mechanical stress factors in high-reliability cable assemblies usually requires the incorporation of various connector backshells and accessories. We offer thousands of EMI management products, cable-sealing backshells, protective covers, strain-relief devices and other essential accessories. In this section of the book we've organized a small selection of some of the most practical devices used in Mil-Aero cabling. We've chosen the most popular and useful products for assemblies built around the D38999 family.

could include both a suitable EMI filtering device but also an appropriate selection of accessories such as shield termination backshells, EMI gaskets and conductive shielding.

For environmental protection, Glenair offers both standard shrink-boot products as well as more robust cable-sealing backshells and protective covers. For mechanical protection we offer a broad range of strain-relief backshells to prevent damage to the conductor-to-contact interface. Whatever your requirement, Glenair has both the connectors, and the accessories, to put

Glenair is the world's largest supplier of EMI Shielding backshells, cable sealing backshells and strain-relief devices. Over 65,000 part numbers are in stock and ready for same-day shipment

This section includes just a small selection of the most practical connector accessories designed for use on D38999 connectors

Glenair offers both AS85049 QPL solutions as well as a broad selection of commercial designs for every electrical, mechanical and environmental requirement.

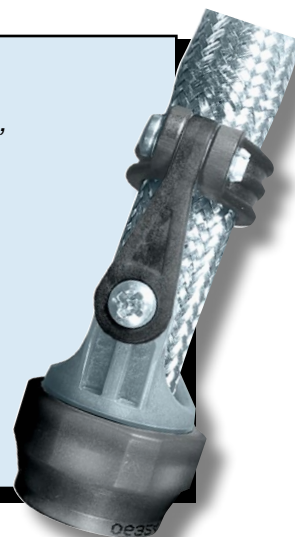

For example, effective shielding of avionic devices equipped with D38999 signal connectors must anticipate both "radiated susceptibility" (the degree to which outside interference affects the reliable functioning of equipment) and "radiated emissions" (the extent to which the device itself creates electromagnetic waves which can affect its function). In both cases, managing the interference

together a finished cable design that meets all the requirements of your application.

NOTE: *Catalog contents are accurate to the best of our ability when we go to print. When errors or mistakes are brought to our attention, corrected content is posted immediately to our website: www.glenair.com.*

Military Standard Circular Connector Accessories

Military Connector Specifications	Shrink Boot Adapters	Non Environmental Strain Relief Backshells	EMI/RFI Non-Environmental Backshells	EMI/RFI Environmental Backshells	Banding Backshells
MIL-C-38999 Series I	M85049/62 Straight	M85049/29 Straight	M85049/36 Straight M85049/37 90°	M85049/17 Straight M85049/76 90° M85049/77 45°	M85049/85 Straight M85049/86 45° M85049/87 90°
MIL-C-38999 Series II	M85049/62 Straight	M85049/29 Straight	M85049/36 Straight M85049/37 90°	M85049/17 Straight M85049/76 90° M85049/77 45°	M85049/85 Straight M85049/86 45° M85049/87 90°
MIL-C-38999 Series III	M85049/69 Straight	M85049/21 Straight	M85049/19 Straight	M85049/18 Straight M85049/78 45° M85049/79 90°	M85049/88 Straight M85049/89 45° M85049/90 90°
MIL-C-38999 Series IV	M85049/69 Straight	M85049/21 Straight	M85049/19 Straight	M85049/18 Straight M85049/78 45° M85049/79 90°	M85049/88 Straight M85049/89 45° M85049/90 90°

MIL-DTL-38999 Backshells and Accessories Selection Guide



Military Standard Circular Connector Accessories

Quick-Ty Strain Reliefs		Strain Reliefs		Dummy Stowage Receptacles	Protective Plug Covers	Protective Receptacle Covers	Military Connector Specifications
Non-Self Locking	Self Locking	Non-Self Locking	Self Locking				
M85049/56 straight M85049/57 45° M85049/58 90°	No Ground Lug M85049/56S Straight M85049/57S 45° W/ Ground Lug M85049/56G Straight M85049/57G 45°	M85049/45 Straight M85049/46 90° M85049/47 (MS27507) 90° M85049/49 (MS27506) Straight	M85049/47S 90° M85049/49S Straight	M38999/9	MS27501	MS27502	MIL-C-38999 Series I
M85049/56 straight M85049/57 45° M85049/58 90°	No Ground Lug M85049/56S Straight M85049/57S 45° W/ Ground Lug M85049/56G Straight M85049/57G 45°	M85049/45 Straight M85049/46 90° M85049/47 (MS27507) 90° M85049/49 (MS27506) Straight	M85049/47S 90° M85049/49S Straight	M38999/10	MS27510	MS27511	MIL-C-38999 Series II
M85049/15 45° M85049/16 90°	N/A	M85049/38 Straight M85049/39 90° M85049/91 Straight M85049/92 90°	M85049/38S Straight M85049/39S 90°	M38999/22	D38999/32 Threaded	D38999/33 Threaded	MIL-C-38999 Series III
M85049/15 45° M85049/16 90°	M85049/15 45° M85049/16 90°	M85049/38 Straight M85049/39 90° M85049/91 Straight M85049/92 90°	M85049/38S Straight M85049/39S 90°	M38999/50	N/A	N/A	MIL-C-38999 Series IV



**Table I:
Backshell Interface Dimensions**

TABLE I: BACKSHELL INTERFACE DIMENSIONS						
CONNECTOR DESIGNATOR		A THREAD REFERENCE	B DIA MAX	C DIA MAX	D DIA MAX	E DIA MAX
F	H					
08 [9]		7/16 – 28 UNEF	.590 (15.)	.650 (16.5)	.770 (19.6)	.690 (17.5)
	09 [A]	M12 x 1 – 6H	.650 (16.5)	.770 (19.6)		.940 (24.8)
10 [11]		9/16 – 24 UNEF	.720 (18.3)	.770 (19.6)	.890 (22.6)	.820 (20.8)
	11 [B]	M15 x 1 – 6H	.770 (19.6)	.820 (20.8)		1.060 (26.9)
12 [13]		11/16 – 24 UNEF	.840 (21.3)	.890 (22.6)	1.020 (25.9)	.940 (23.8)
	13 [C]	M18 x 1 – 6H	.890 (22.6)	.940 (23.9)		1.170 (29.7)
14 [15]		13/16 – 20 UNEF	.970 (24.6)	1.020 (29.2)	1.150 (29.2)	1.060 (26.9)
	15 [D]	M22 x 1 – 6H	1.030 (26.2)	1.070 (26.2)		1.290 (32.7)
16 [17]		15/16 – 20 UNEF	1.090 (27.7)	1.150 (29.2)	1.260 (32.0)	1.170 (29.7)
	17 [E]	M25 x 1 – 6H	1.150 (29.2)	1.210 (30.7)		1.420 (36.1)
18 [19]		1 1/16 – 18 UNEF	1.220 (31.0)	1.230 (31.2)	1.400 (35.6)	1.290 (32.7)
	19 [F]	M28 x 1 – 6H	1.280 (32.5)	1.360 (34.5)		1.540 (39.1)
20 [21]		1 3/16 – 18 UNEF	1.340 (34.0)	1.360 (34.5)	1.530 (38.9)	1.420 (36.0)
	21 [G]	M31 x 1 – 6H	1.410 (35.8)	1.480 (37.6)		1.670 (42.4)
22 [23]		1 5/16 – 18 UNEF	1.470 (37.3)	1.480 (37.6)	1.600 (40.6)	1.540 (39.1)
	23 [H]	M34 x 1 - 6H	1.530 (38.9)	1.600 (40.6)		2.010 (51.1)
24 [25]		1 7/16 – 18 UNEF	1.590 (40.4)	1.730 (43.9)	1.940 (49.3)	1.660 (42.2)
	25 [J]	M37 x 1 – 6H	1.660 (42.2)	1.700 (43.2)		2.120 (53.8)



770-001 Shrink Boot Heat Shrink Molded Part

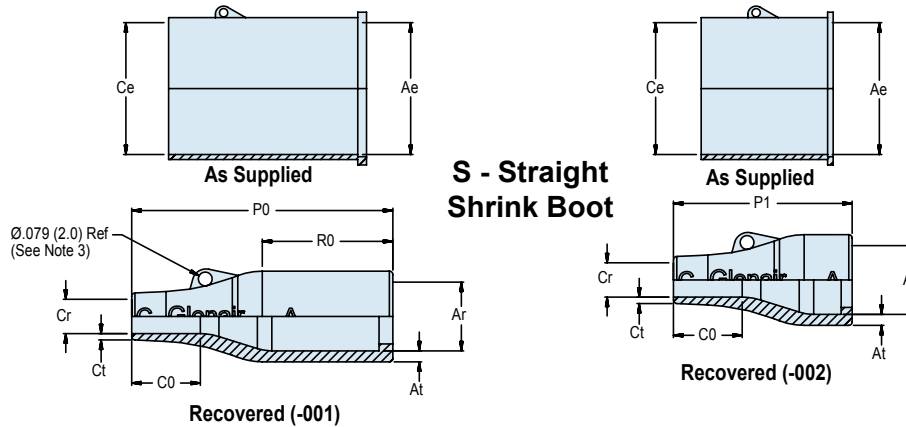
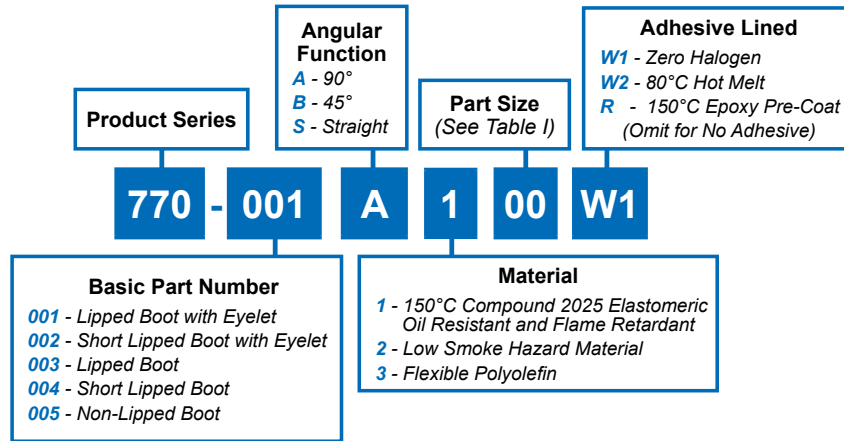
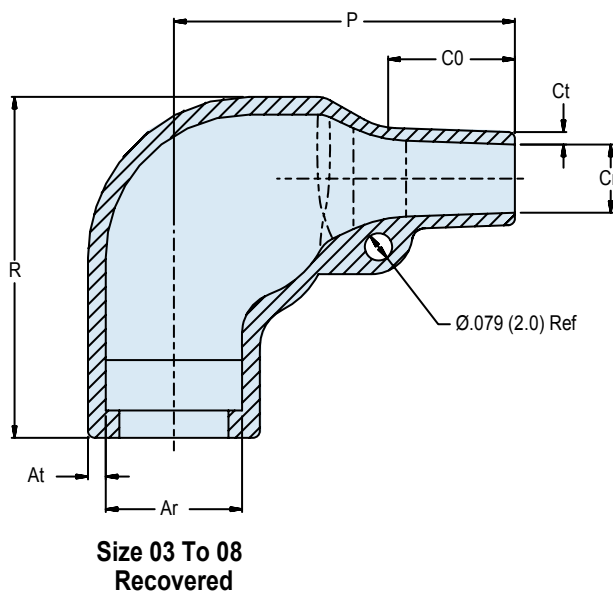
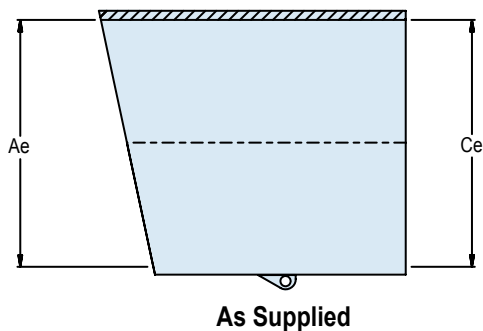

TABLE I: STRAIGHT BOOT DIMENSIONS, BOOT AND SHELL SIZE

Boot Size	Shell Size	Ae Dia Min	Ce Dia Min	Ar Dia Max	at ±30%	Cr Dia Max	ct ±20%	C0 Ref	P0 ±10%	P1 ±10%	R0 Ref
00	5	.354 (9.0)	.354 (9.0)	.217 (5.5)	.039 (1.0)	.079 (2.0)	.028 (0.7)	.295 (7.5)	.984 (25.0)	N/A	.551 (14.0)
01	5, 6	.472 (12.0)	.472 (12.0)	.276 (7.0)	.043 (1.1)	.118 (3.0)	.028 (0.7)	.295 (7.5)	.984 (25.0)	N/A	.551 (14.0)
02	6, 7	.669 (17.0)	.669 (17.0)	.276 (7.0)	.051 (1.3)	.138 (3.5)	.028 (0.7)	.395 (10.0)	1.181 (30.0)	N/A	.728 (18.5)
03	8, 10	.945 (24.0)	.945 (24.0)	.413 (10.5)	.063 (1.6)	.197 (5.5)	.035 (0.9)	.395 (10.0)	1.496 (38.0)	1.024 (26.0)	.748 (19.0)
04	11-16	1.181 (30.0)	1.181 (30.0)	.551 (14.0)	.071 (1.8)	.236 (6.0)	.039 (1.0)	.630 (16.0)	2.165 (55.0)	1.693 (43.0)	1.181 (30.0)
05	16-17	1.260 (32.0)	1.260 (32.0)	.709 (18.0)	.071 (1.8)	.276 (7.0)	.047 (1.2)	.748 (19.0)	2.638 (67.0)	1.850 (47.0)	1.299 (33.0)
06	17-21	1.417 (36.0)	1.417 (36.0)	.886 (22.0)	.079 (2.0)	.335 (8.5)	.047 (1.2)	.787 (20.0)	3.150 (80.0)	2.362 (60.0)	1.575 (40.0)
07	21-23	1.693 (43.0)	1.693 (43.0)	1.102 (28.0)	.087 (2.2)	.394 (10.0)	.051 (1.3)	1.142 (29.0)	3.898 (99.0)	3.150 (80.0)	2.165 (55.0)
08	25	2.362 (60.0)	2.362 (60.0)	1.378 (35.0)	.130 (3.3)	.591 (15.0)	.063 (1.6)	1.575 (40.0)	5.118 (130.0)	4.331 (110.0)	1.969 (50.0)

APPLICATION NOTES

1. Material: Fluid resistant elastomer - Glenair Material Type 1.
2. When the minimum number of conductors are used, wire bundle/cable may require build-up to B² max.
3. Sizes 00 to 02 do not contain eyelet.



**A - 90°
Shrink Boot**

TABLE I: 90° BOOT DIMENSIONS, BOOT AND SHELL SIZE

Boot Size	Shell Size	Ae Dia Min	Ce Dia Min	Ar Dia Max	at ±30%	Cr Dia Max	ct ±20%	C0 Ref	P ±20%	R Ref
03	9	.945 (24.0)	.945 (24.0)	.394 (10.0)	.063 (1.6)	.197 (5.0)	.035 (0.9)	.394 (10.0)	.984 (25.0)	.984 (25.0)
04	11-15	1.181 (30.0)	1.181 (30.0)	.532 (13.5)	.071 (1.8)	.217 (5.5)	.039 (1.0)	.472 (12.0)	1.260 (32.0)	1.063 (27.0)
05	13-17	1.260 (32.0)	1.260 (32.0)	.709 (18.0)	.071 (1.8)	.276 (7.0)	.047 (1.2)	.591 (15.0)	1.535 (39.0)	1.260 (32.0)
06	17-21	1.417 (36.0)	1.417 (36.0)	.886 (22.0)	.079 (2.0)	.335 (8.5)	.047 (1.2)	.630 (16.0)	1.929 (49.0)	1.496 (38.0)
07	21-23	1.693 (43.0)	1.693 (43.0)	1.102 (28.0)	.087 (2.2)	.394 (10.0)	.059 (1.5)	.709 (18.0)	2.165 (55.0)	1.850 (47.0)
08	23-25	2.165 (55.0)	2.165 (55.0)	1.378 (35.0)	.130 (3.3)	.591 (15.0)	.079 (2.0)	1.260 (32.0)	3.150 (80.0)	2.165 (55.0)



770-001
45° Shrink Boot
Heat Shrink Molded Part

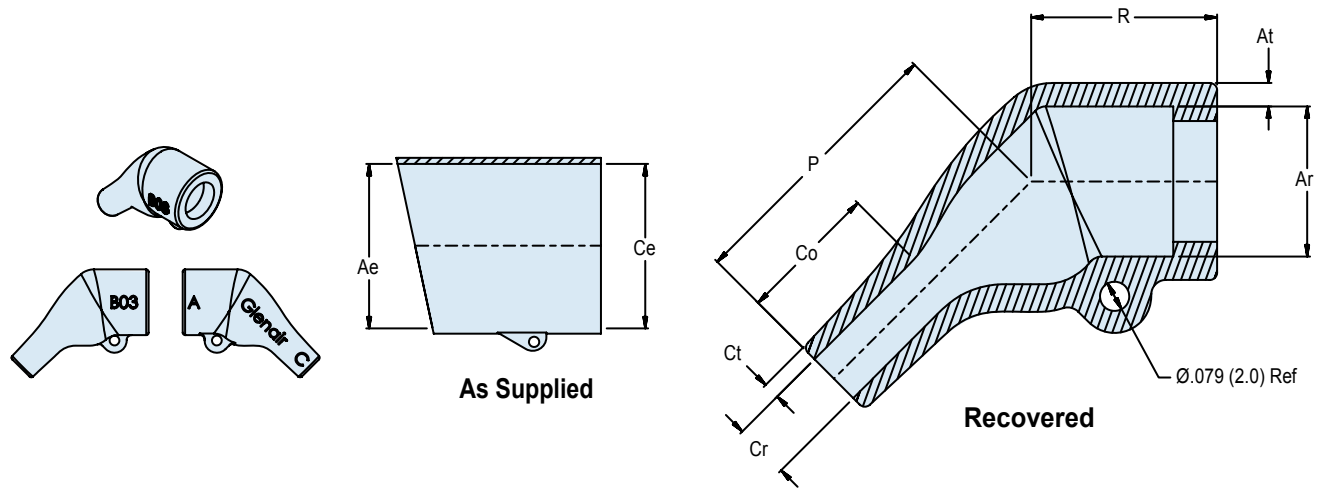

B - 45°
Shrink Boot

TABLE I: 45° BOOT DIMENSIONS, BOOT AND SHELL SIZE

Boot Size	Shell Size	Ae Dia Min	Ce Dia Min	Ar Dia Max	at ±30%	Cr Dia Max	ct ±20%	CO Ref	P ±10%	R Ref
03	9	.945 (24.0)	.945 (24.0)	.413 (10.50)	.063 (1.6)	.157 (4.0)	.035 (0.9)	.315 (8.0)	.748 (195.0)	.500 (12.7)
04	11-15	1.181 (30.0)	1.181 (30.0)	.551 (14.0)	.071 (1.8)	.236 (6.0)	.039 (1.0)	.354 (9.0)	1.180 (30.0)	.748 (19.0)
05	13-17	1.260 (32.0)	1.260 (32.0)	.709 (18.0)	.079 (2.0)	.276 (7.0)	.071 (1.8)	.591 (15.0)	1.378 (35.0)	.984 (25.0)
06	17-21	1.417 (36.0)	1.417 (36.0)	.886 (22.0)	.079 (2.0)	.335 (8.5)	.071 (1.8)	.709 (18.0)	1.575 (40.0)	1.260 (32.0)
07	21-23	1.693 (43.0)	1.693 (43.0)	1.102 (28.0)	.087 (2.2)	.394 (10.0)	.079 (2.0)	.709 (18.0)	1.772 (45.0)	1.496 (38.0)

Connector Designators:

MIL-DTL-38999 Series I, II (F)
MIL-DTL-38999 Series III and IV (H)

F-H
**ROTATABLE
COUPLING**

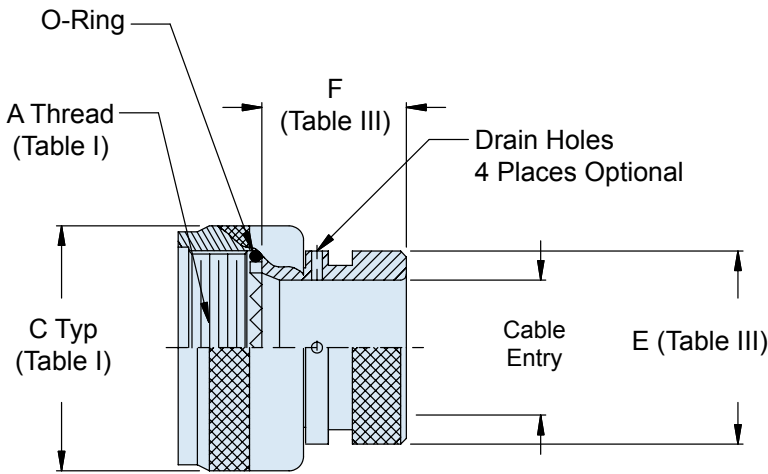
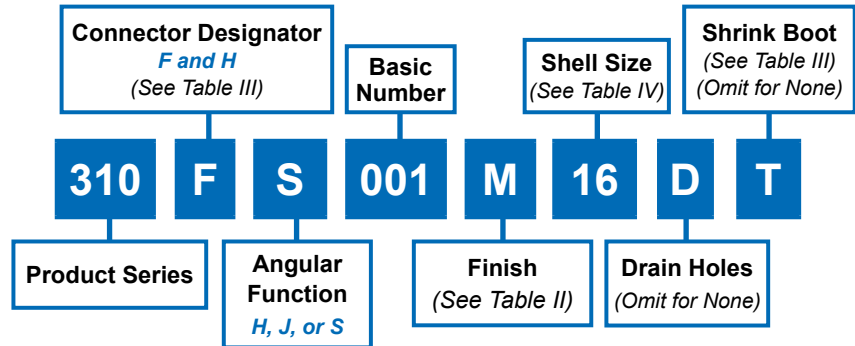
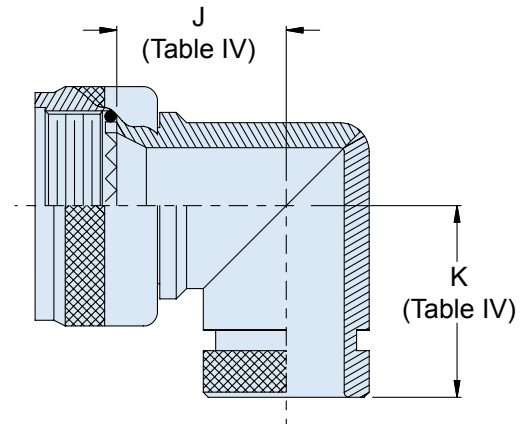
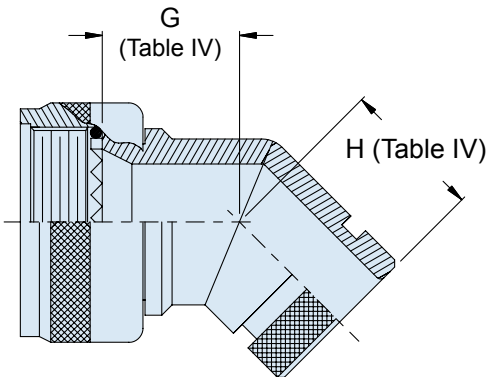

TABLE II: FINISHES

Symbol	Finish
B	Cadmium Plate, Olive Drab
C	Anodize, Black
GB	Black Anodize, Hard Coat
M	Electroless Nickel
N	Cad Plate, Olive Drab over Electroless Nickel
NF	Cadmium Plate, Olive Drab over Electroless Nickel
MT	Ni-PTFE 1000 Hour Grey™ Nickel Fluorocarbon Polymer
Z1	Stainless Steel Passivate
ZL	CRES, Electroless Nickel
ZN	Zinc-Nickel



310-001 O-Ring Sealed Shrink Boot Adapter Rotatable Coupling - Standard Profile



TABLE III: CABLE ENTRY AND SHRINK BOOT

Connector Designator F	Connector Designator H	E Max	F Max	Cable Entry Min	Shrink Boot*
08	09	.533 (13.5)	.940 (23.9)	.250 (6.4)	770-003S102
10	11	.605 (15.4)	.940 (23.9)	.355 (9.0)	770-001S103
12	13	.774 (19.7)	.940 (23.9)	.491 (12.5)	770-001S103
14	15	.838 (21.3)	.940 (23.9)	.565 (14.4)	770-001S103
16	17	.963 (24.5)	.940 (23.9)	.690 (17.5)	770-001S104
18	19	1.042 (26.5)	.940 (23.9)	.769 (19.5)	770-001S104
20	21	1.217 (30.9)	.940 (23.9)	.894 (22.7)	770-001S106
22	23	1.355 (34.4)	.940 (23.9)	1.019 (25.9)	770-001S107
24	25	1.443 (36.7)	.940 (23.9)	1.134 (28.8)	770-001S107
28	29	1.709 (43.4)	.940 (23.9)	1.369 (34.8)	770-001S108
32	33	1.919 (48.7)	1.005 (25.5)	1.615 (41.0)	770-001S108

TABLE IV: BACKSHELL DIMENSIONS

Connector Designator F	Connector Designator H	G Max	H Max	J Max	K Max
08	09	.639 (16.2)	.810 (20.6)	.750 (19.1)	.920 (23.4)
10	11	.664 (16.9)	.840 (21.3)	.810 (20.6)	.980 (24.9)
12	13	.688 (17.5)	.860 (21.8)	.870 (22.1)	1.040 (26.4)
14	15	.705 (17.9)	.890 (22.6)	.920 (23.4)	1.110 (28.2)
16	17	.732 (18.6)	.910 (23.1)	.980 (24.9)	1.170 (29.7)
18	19	.748 (19.0)	.920 (23.4)	1.020 (25.9)	1.190 (30.2)
20	21	.773 (19.6)	.940 (23.9)	1.080 (27.4)	1.250 (31.8)
22	23	.800 (20.3)	.980 (24.9)	1.140 (29.0)	1.330 (33.8)
24	25	.823 (20.9)	1.010 (25.7)	1.200 (30.5)	1.400 (35.6)
28	29	1.041 (26.4)	1.180 (30.0)	1.480 (37.6)	1.640 (41.7)
32	33	1.092 (27.7)	1.370 (34.8)	1.610 (40.9)	1.880 (47.8)

APPLICATION NOTES

1. See shrink boot reference information (Page G-5).
2. O-Rings not supplied with drain hole option.
3. O-Rings not supplied with Connector Designators A and G.
4. Metric dimensions (mm) indicated in parentheses.



319-064
Composite Self-Locking Rotatable Coupling
 Swing-Arm Strain Relief with
 Nickel/Copper EMI/RFI Shield Sock & Optional Split Ring

**CONNECTOR
 DESIGNATOR**

MIL-DTL-38999 Series I, II (F)
 (for Series II see note 6)
 MIL-DTL-38999 Series III and IV (H)

F-H

SELF-LOCKING

**ROTATABLE
 COUPLING**

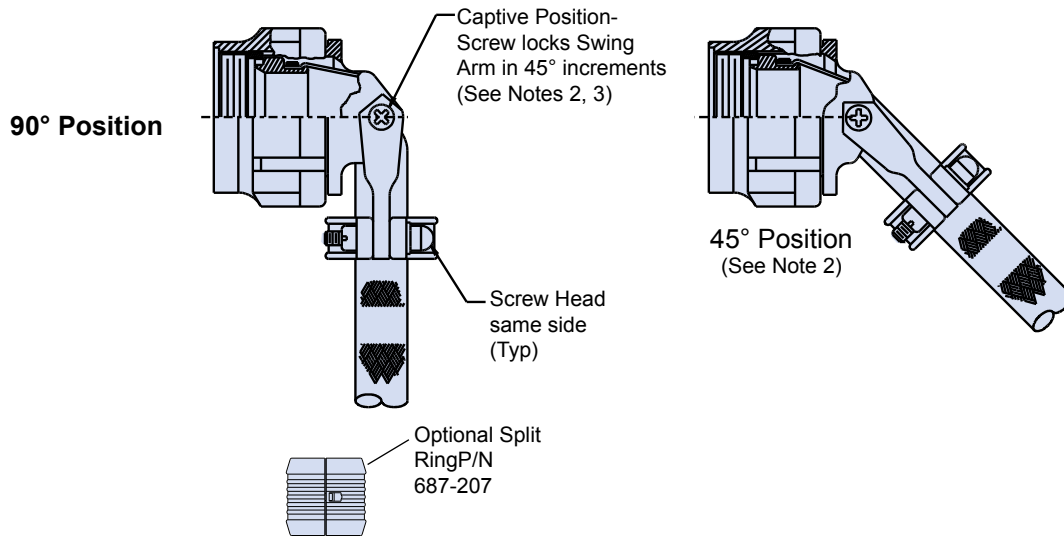
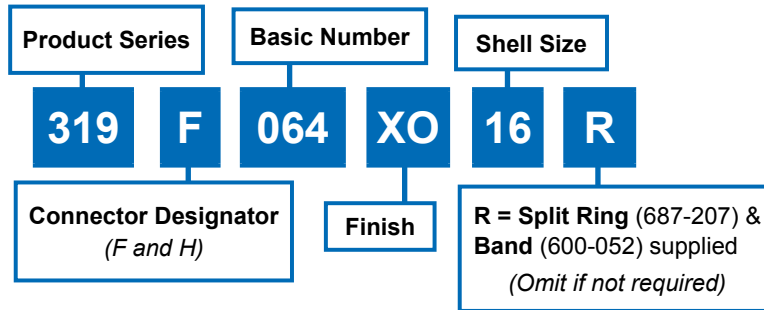

U.S. PATENT NO. 6419519

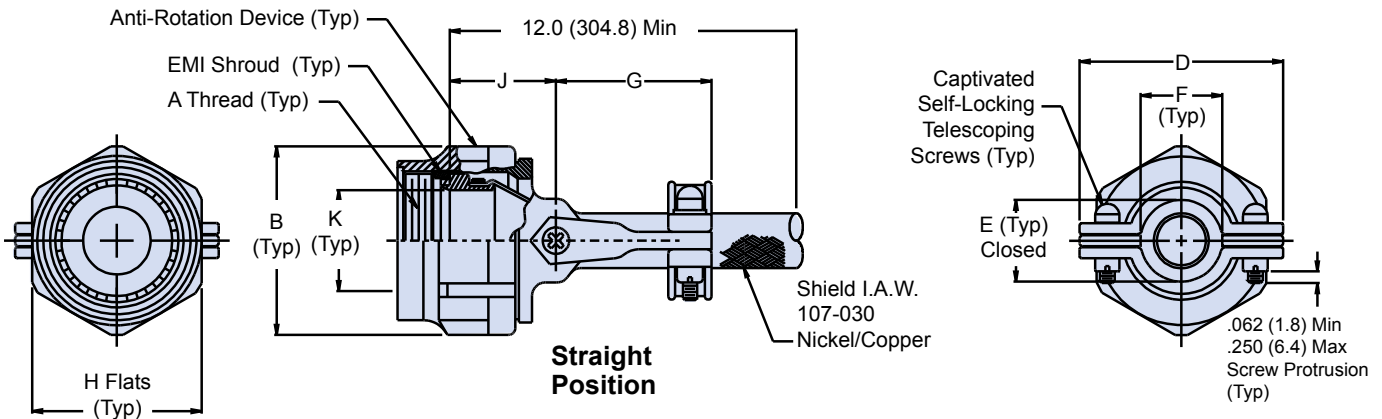

H

319-064
Composite Self-Locking Rotatable Coupling
Composite Swing-Arm Strain Relief with
Nickel/Copper EMI/RFI Shield Sock & Optional Split Ring



TABLE II: FINISHES	
Symbol	Finish
XB	Composite Material, No Plating, Color Black, Brass Interface Shroud and Adapter - Nickel Plated
XMT	Composite Material, No Plating, Color Black and Brown, Brass Interface Shroud and Adapter - Ni-PTFE 1000 Hour Grey™ (Nickel-Fluorocarbon Polymer)
XN	Composite Material, No Plating, Color Black and Brown, Brass Interface Shroud and Adapter - Selectively Cadmium Plated
XO	Composite Material, No Plating, Color Black and Brown, Brass Interface Shroud and Adapter - Nickel Plated

TABLE III: CONNECTOR SHELL SIZE ORDER NUMBER										
Shell Size for Connector Designator		B Dia	D	E	F	G	H Flats		J	K
F	H	Max	Max	±.06 (1.5)	Min	Max	Max	Min	±.06 (1.5)	Ref
08	09	.812 (20.6)	.980 (24.9)	.265 (6.7)	.220 (5.9)	1.060 (26.9)	.750 (19.1)	.736 (18.7)	.940 (23.9)	.265 (6.7)
10	11	.938 (23.8)	1.050 (26.7)	.310 (7.9)	.270 (6.9)	1.090 (27.7)	.875 (22.2)	.860 (21.8)	.970 (24.6)	.370 (9.4)
12	13	1.125 (28.6)	1.200 (30.5)	.390 (9.9)	.350 (8.9)	1.180 (30.0)	1.000 (25.4)	.980 (24.9)	1.030 (26.2)	.506 (12.9)
14	15	1.250 (31.8)	1.300 (33.0)	.506 (12.9)	.470 (11.9)	1.240 (31.5)	1.125 (28.6)	1.100 (27.9)	1.090 (27.7)	.580 (14.7)
16	17	1.375 (34.9)	1.440 (36.6)	.591 (15.0)	.550 (14.0)	1.320 (33.5)	1.250 (31.8)	1.224 (31.1)	1.120 (28.4)	.705 (17.9)
18	19	1.500 (38.1)	1.560 (39.6)	.661 (16.8)	.620 (15.7)	1.390 (35.3)	1.375 (34.9)	1.469 (37.3)	1.150 (29.2)	.784 (19.9)
20	21	1.625 (41.3)	1.690 (42.9)	.744 (18.9)	.700 (17.8)	1.550 (39.4)	1.500 (38.1)	1.500 (38.1)	1.180 (30.0)	.909 (23.1)
22	23	1.750 (44.5)	1.770 (45.0)	.826 (21.0)	.780 (19.8)	1.550 (39.4)	1.625 (41.3)	1.581 (40.2)	1.250 (31.8)	1.034 (26.3)
24	25	1.875 (47.6)	1.890 (48.0)	.896 (22.8)	.850 (21.6)	1.610 (40.9)	1.750 (44.5)	1.960 (49.8)	1.280 (32.5)	1.149 (29.2)

Consult factory for additional entry sizes available.

APPLICATION NOTES

- Glenair series 600 Backshell assembly Tools are recommended for assembly and installation.
- Swing Arm locks in 45° increments—Sizes 08 thru 24, additional positioning increments are manufacturer's option.
- Captive Screw can remain engaged to the body when positioning the Arm. When tightened, the Screw shall not protrude into the inside surfaces.
- Fits Connector Designators: MIL-DTL-38999 Series I, II (F), MIL-DTL-38999 Series III and IV (H), MIL-DTL-5015 (A), and MIL-DTL-26482 (A).
- Metric dimensions (mm) are indicated in parentheses.
- For Mil-DTL-38999 Series II, add Mod Code -475. Backshell supplied less shroud.



319-065
Composite Self-Locking Rotatable Coupling
 Swing-Arm Strain Relief with
 Composite EMI/RFI Shield Sock & Optional Split Ring

**CONNECTOR
 DESIGNATOR**

MIL-DTL-38999 Series I, II (F)
 MIL-DTL-38999 Series III and IV (H)

F-H

SELF-LOCKING

**ROTATABLE
 COUPLING**

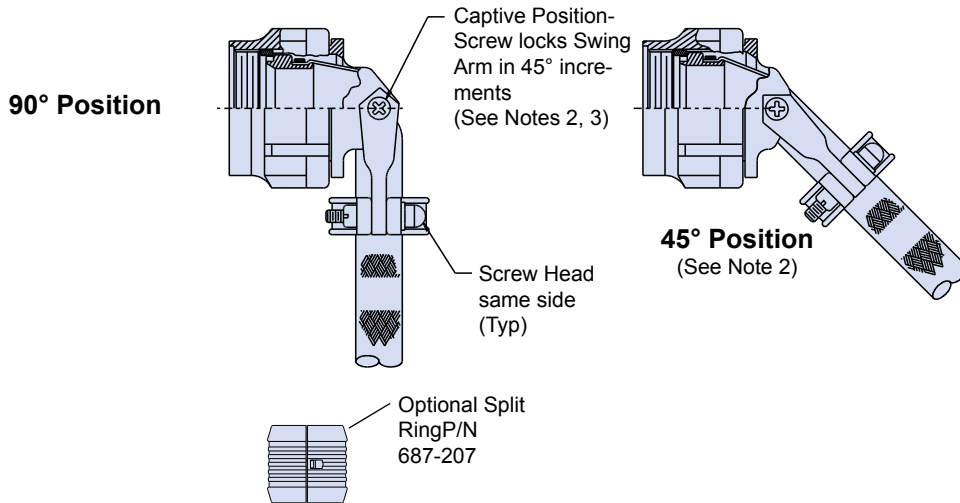
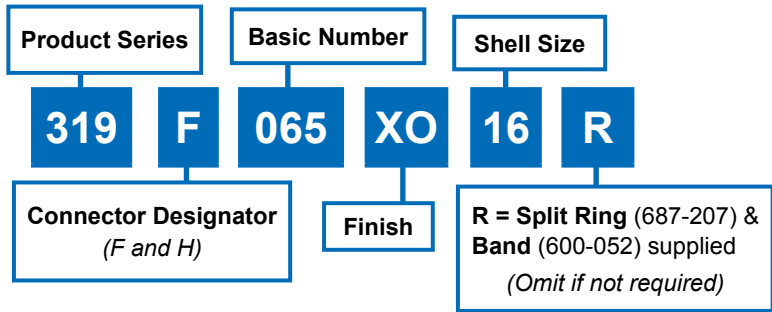

U.S. PATENT NO. 6419519

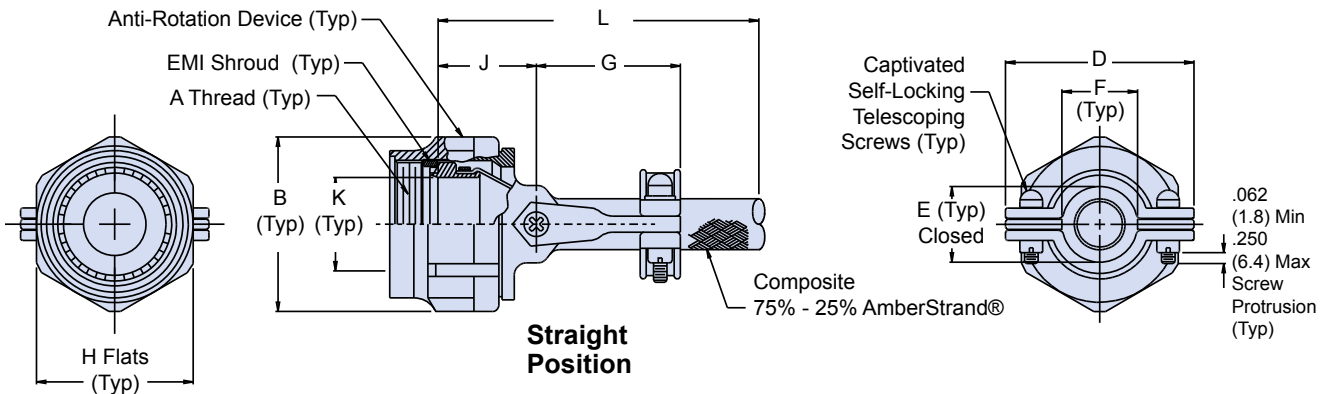

H

319-065
Composite Self-Locking Rotatable Coupling
Swing-Arm Strain Relief with
Composite EMI/RFI Shield Sock & Optional Split Ring



TABLE II: FINISHES	
Symbol	Finish
XB	Composite Material, No Plating, Color Black, Brass Interface Shroud and Adapter - Nickel Plated
XMT	Composite Material, No Plating, Color Black and Brown, Brass Interface Shroud and Adapter - Ni-PTFE 1000 Hour Grey™ (Nickel-Fluorocarbon Polymer)
XN	Composite Material, No Plating, Color Black and Brown, Brass Interface Shroud and Adapter - Selectively Cadmium Plated
XO	Composite Material, No Plating, Color Black and Brown, Brass Interface Shroud and Adapter - Nickel Plated

TABLE III: CONNECTOR SHELL SIZE ORDER NUMBER											
Shell Size for Connector Designator		B Dia Max	D Max	E ±.06 (1.5)	F Min	G Max	H Flats		J ±.06 (1.5)	K Ref	L Min
F	H						Max	Min			
08	09	.812 (20.6)	.980 (24.9)	.265 (6.7)	.220 (5.9)	1.060 (26.9)	.750 (19.1)	.736 (18.7)	.940 (23.9)	.265 (6.7)	7.000 (177.8)
10	11	.938 (23.8)	1.050 (26.7)	.310 (7.9)	.270 (6.9)	1.090 (27.7)	.875 (22.2)	.860 (21.8)	.970 (24.6)	.370 (9.4)	7.000 (177.8)
12	13	1.125 (28.6)	1.200 (30.5)	.390 (9.9)	.350 (8.9)	1.180 (30.0)	1.000 (25.4)	.980 (24.9)	1.030 (26.2)	.506 (12.9)	7.000 (177.8)
14	15	1.250 (31.8)	1.300 (33.0)	.506 (12.9)	.470 (11.9)	1.240 (31.5)	1.125 (28.6)	1.100 (27.9)	1.090 (27.7)	.580 (14.7)	9.000 (228.6)
16	17	1.375 (34.9)	1.440 (36.6)	.591 (15.0)	.550 (14.0)	1.320 (33.5)	1.250 (31.8)	1.224 (31.1)	1.120 (28.4)	.705 (17.9)	11.000 (279.4)
18	19	1.500 (38.1)	1.560 (39.6)	.661 (16.8)	.620 (15.7)	1.390 (35.3)	1.375 (34.9)	1.469 (37.3)	1.150 (29.2)	.784 (19.9)	11.000 (279.4)
20	21	1.625 (41.3)	1.690 (42.9)	.744 (18.9)	.700 (17.8)	1.550 (39.4)	1.500 (38.1)	1.500 (38.1)	1.180 (30.0)	.909 (23.1)	11.000 (279.4)
22	23	1.750 (44.5)	1.770 (45.0)	.826 (21.0)	.780 (19.8)	1.550 (39.4)	1.625 (41.3)	1.581 (40.2)	1.250 (31.8)	1.034 (26.3)	11.000 (279.4)
24	25	1.875 (47.6)	1.890 (48.0)	.896 (22.8)	.850 (21.6)	1.610 (40.9)	1.750 (44.5)	1.960 (49.8)	1.280 (32.5)	1.149 (29.2)	11.000 (279.4)

Consult factory for additional entry sizes available.

APPLICATION NOTES

- Glenair series 600 Backshell assembly tools are recommended for assembly and installation.
- Swing Arm Locks in 45° increments—Sizes 08 thru 24, additional positioning increments are manufacturer's option.
- Captive Screw remains engaged to the body when positioning the Arm. When tightened, the Screw shall not protrude into the inside surfaces.
- Fits Connector Designators: MIL-DTL-38999 Series I, II (F), MIL-DTL-38999 Series III and IV (H), MIL-DTL-5015 (A), and MIL-DTL-26482 (A)
- Metric Dimensions (mm) are indicated in parentheses.



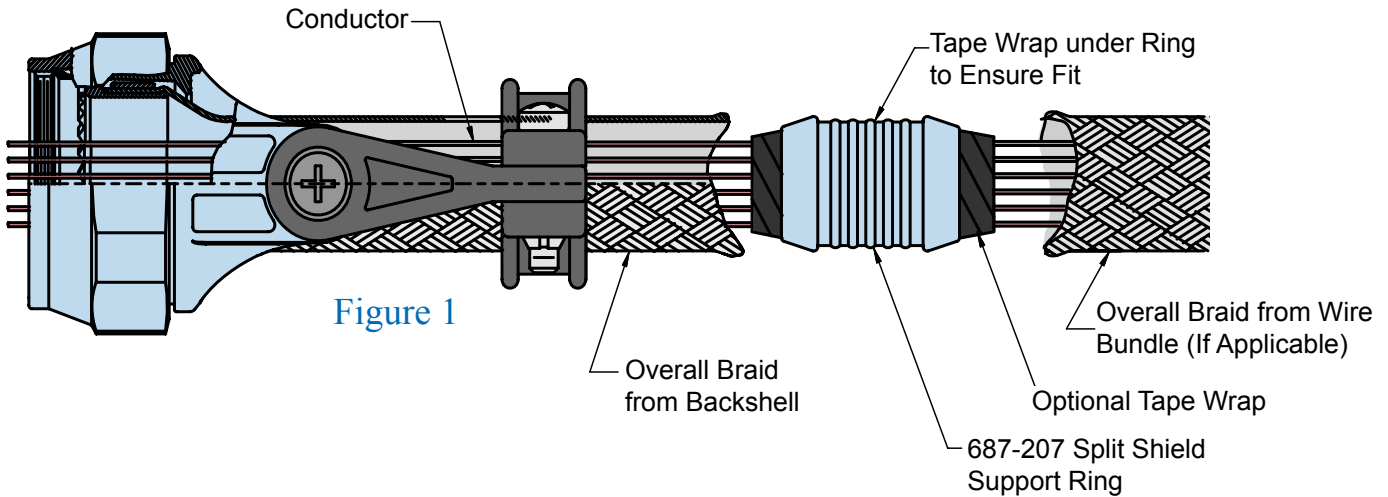

**Glenair Swing-Arm
Offers Extremely Fast and
Trouble-Free Termination
of EMI Shielding:**

Choose Straight, 45° or 90° angle, and tighten screws to lock arms in place. Leave the saddle clamp hardware loose.

Next, insert the wire bundle into the backshell to determine if the braid transition angle from the backshell to wire bundle is less than 45°. If it is less than 45°, build up the wire bundle with tape and re-insert wire bundle into backshell to support the transition of overall braid from the backshell to the wire bundle.

Loosely assembly the adapter to the connector and push back the backshell braid. Insert the wire bundle into the adapter and bottom it against the connector. Holding the cable, mark or tag the location where the shield support ring (Glenair Part Number 687-207) will be located. This distance may vary depending on your technique and the flexibility of the wire bundle immediately to the rear of the saddles (Figure 1).

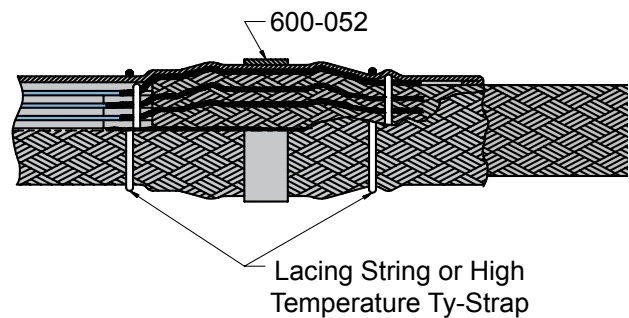

Figure 2

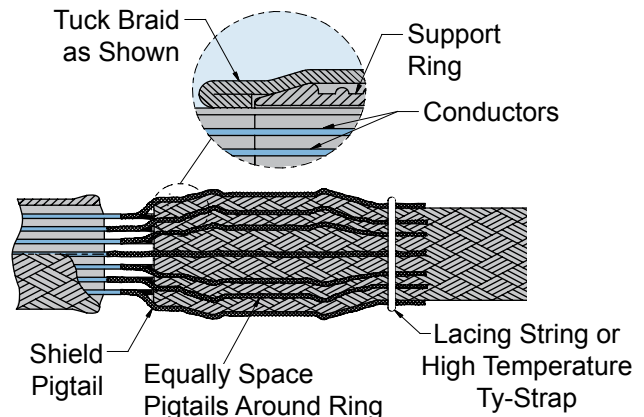

Figure 3

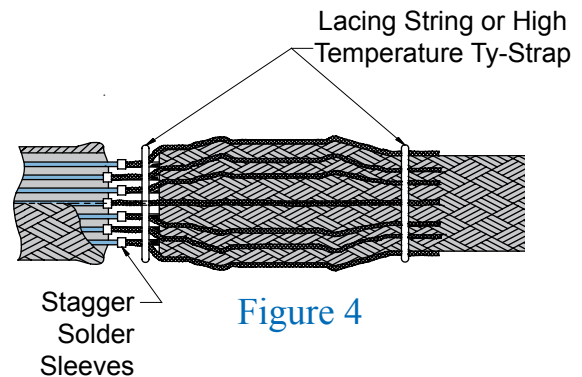
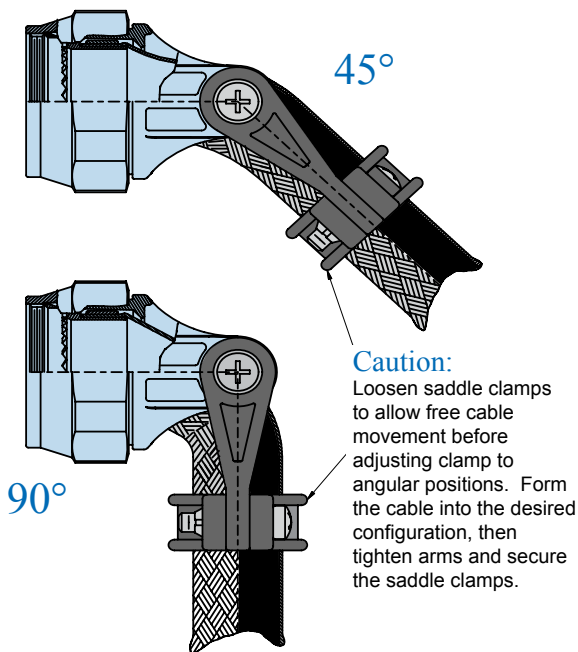

Figure 4

Install Glenair's *Band-it*® band (600-052) between the lace ties onto the center of the support ring as shown in Figure 2. The hand banding tool (600-058) or pneumatic banding tool (600-067) is used for this banding process.

Next, you can wrap the shield support ring assembly with high temperature tape. Place lacing cord, high temperature tape, or high temperature plastic Ty-Straps on the braid transition to the rear of the backshell to secure the overbraid on wire bundle. If you wish, you can cover the overbraid with 102-080 braid sock.

Tighten the adapter to the connector using Glenair 600-091 composite hex coupling torque wrench and related tooling accessories to established torque values. Secure the strain relief saddle onto the wire bundle using TG69 soft jaw pliers. Torque the saddle screws to established values. You can use Teflon tape wrap or M85049/127 bushing strip as needed to cushion the braid sock under the saddle clamps.

With these few steps, your Swing-Arm strain relief installation is complete!

At the marked location, near the shield support ring, wrap tape around wire bundle for snug fit of shield support ring (Figure 1). Tape wrap is optional.

You can then slide the overall braid from the wire bundle side over the shield support ring, trimming braid ends and tucking extra braid underneath itself for a clean appearance.

For pin connectors, slide the backshell forward, and hand tighten backshell to connector. Then, evenly space shield pigtails (Figure 3) or solder sleeve pigtails (Figure 4) around the shield support ring. Cut the pigtails so that the end of the pigtails slightly beyond end of shield support ring.

Bring the shield sock from backshell and completely cover the pigtails and support ring. Trim and fold the braid as shown in Figure 2. Lace tie the shield adjacent to support ring ends.

Connector Designators:

MIL-DTL-38999 Series I, II (F)
 MIL-DTL-38999 Series III and IV (H)

F-H

**SELF-LOCKING
 ROTATABLE
 COUPLING
 TYPE D INDIVIDUAL
 OR OVERALL
 SHIELD TERMINATION**

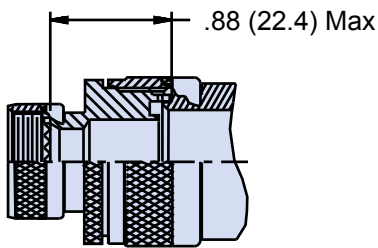
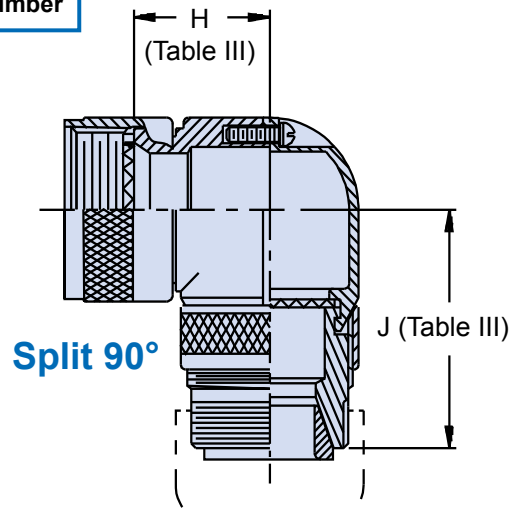
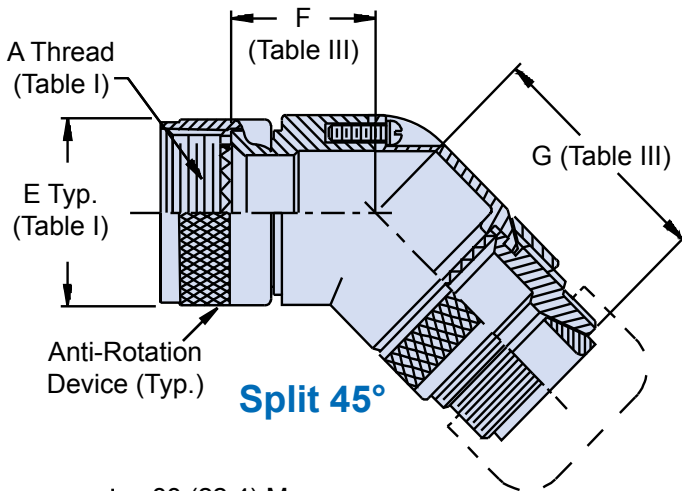
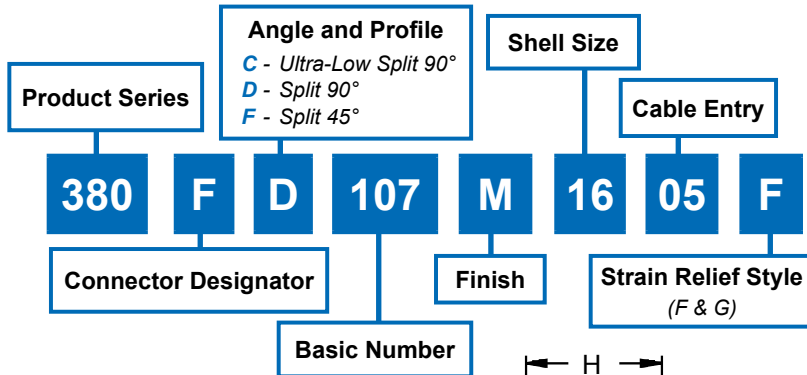

STYLE 2
 (See Note 1)

STYLE F
 Light Duty
 (Table IV)

STYLE G
 Light Duty
 (Table V)

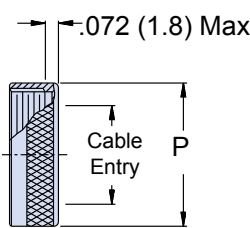
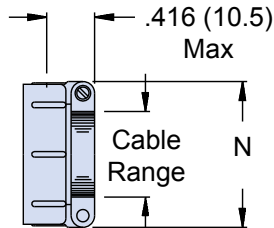
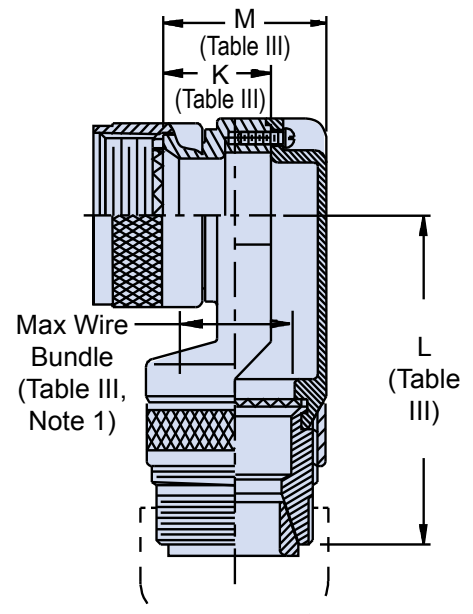

380-107
EMI/RFI Non-Environmental Backshell
 with Strain Relief
 Type D - Self-Locking - Rotatable Coupling - Split Shell



Shell Size	F Max	G Max	H Max	J Max	K Max	L Max	M Max	Function C Max Wire Bundle
08/09	.596 (15.1)	1.730 (43.9)	.836 (21.2)	1.670 (42.4)	.496 (12.6)	1.920 (48.8)	.837 (21.3)	250 (6.4)
10/11	.656 (16.7)	1.785 (45.3)	.906 (23.0)	1.725 (43.8)	.426 (10.8)	2.080 (52.8)	.887 (22.5)	.375 (9.5)
12/13	.716 (18.2)	1.855 (47.1)	.966 (24.5)	1.795 (45.6)	.426 (10.8)	2.080 (52.8)	.887 (22.5)	.375 (9.5)
14/15	.776 (19.7)	1.887 (47.9)	1.026 (26.1)	1.827 (46.4)	.436 (11.1)	2.150 (54.6)	.987 (25.1)	.500 (12.7)
16/17	.836 (21.2)	1.987 (50.5)	1.086 (27.6)	1.927 (48.9)	.576 (14.6)	2.200 (55.9)	1.137 (28.9)	.625 (15.9)
18/19	.906 (23.0)	2.045 (51.9)	1.156 (29.4)	1.985 (50.4)	.796 (20.2)	2.230 (56.6)	1.337 (34.0)	.625 (15.9)
20/21	.976 (24.8)	2.106 (53.5)	1.216 (30.9)	2.046 (52.0)	.796 (20.2)	2.230 (56.6)	1.337 (34.0)	.625 (15.9)
22/23	1.036 (26.3)	2.167 (55.0)	1.276 (32.4)	2.107 (53.5)	.696 (17.7)	2.380 (60.5)	1.337 (34.0)	.750 (19.1)
24/25	1.096 (27.8)	2.225 (56.5)	1.336 (33.9)	2.165 (55.0)	.696 (17.7)	2.380 (60.5)	1.337 (34.0)	.750 (19.1)

Symbol	Finish
B	Cadmium Plate, Olive Drab
C	Anodize, Black
GB	Black Anodize, Hard Coat
M	Electroless Nickel
N	Cad Plate, Olive Drab over Electroless Nickel
NF	Cadmium Plate, Olive Drab over Electroless Nickel
MT	Ni-PTFE 1000 Hour Grey™ Nickel Fluorocarbon Polymer
ZN	Zinc-Nickel

Dash No.	N Max	Cable Range	
		Min	Max
02	.968 (24.6)	.125 (3.2)	.250 (6.4)
03	1.046 (26.6)	.250 (6.4)	.375 (9.5)
04	1.156 (29.4)	.312 (7.9)	.500 (12.7)
05	1.218 (30.9)	.437 (11.1)	.625 (15.9)
06	1.343 (34.1)	.562 (14.3)	.750 (19.1)
07	1.468 (37.3)	.687 (17.4)	.875 (22.2)
08	1.593 (40.5)	.812 (20.6)	1.000 (25.4)
10	1.843 (46.8)	1.062 (27.0)	1.250 (31.8)

Dash No.	N Max	Cable Entry Max
02	.656 (16.7)	.125 (3.2)
03	.781 (19.8)	.250 (6.4)
04	.906 (23.0)	.375 (9.5)
05	1.031 (26.2)	.500 (12.7)
06	1.156 (29.4)	.625 (15.9)
07	1.281 (32.5)	.750 (19.1)
08	1.406 (35.7)	.875 (22.2)
09	1.531 (38.9)	1.000 (25.4)
10	1.656 (42.1)	1.125 (28.6)

APPLICATION NOTES

1. When maximum cable entry is exceeded (not available in Function C), Style 2 will be supplied. Dimensions F, G, H and J will not apply. Please consult factory.
2. Cable range is defined as the accommodations range for the wire bundle or cable.
3. Dimensions shown are not intended for inspection criteria.
4. Angular function "C", low-profile split elbow, not available with "S" connector designator.
5. Metric dimensions (mm) are indicated in parentheses.

380-115
EMI/RFI Non-Environmental Backshell
with Strain Relief
Type B - Rotatable Coupling - Low Profile

**CONNECTOR
DESIGNATORS**

MIL-DTL-38999 Series I, II (F)
MIL-DTL-38999 Series III and IV (H)

F-H

**ROTATABLE
COUPLING**

**TYPE B INDIVIDUAL
AND/OR OVERALL
SHIELD TERMINATION**

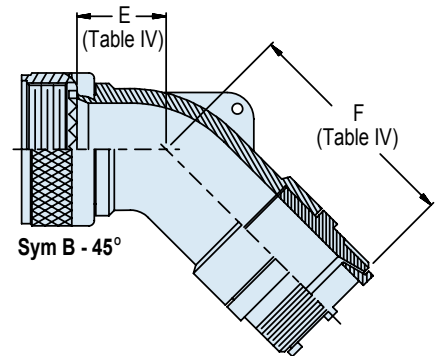
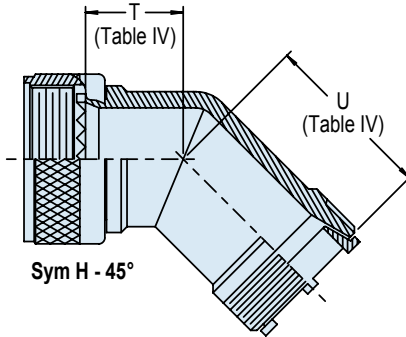
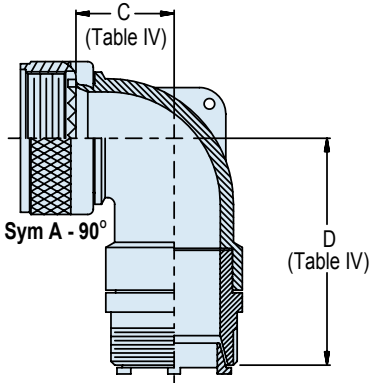
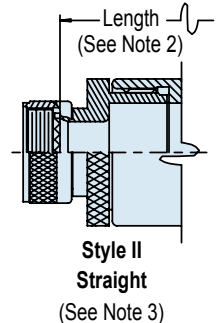
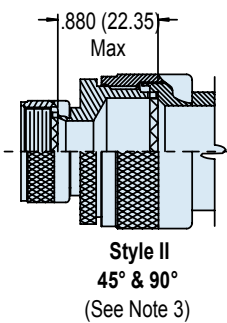
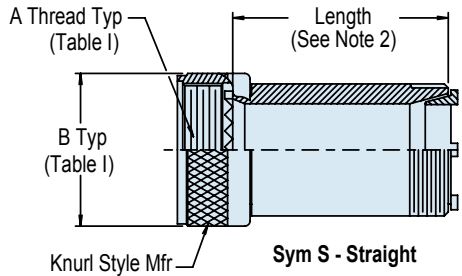
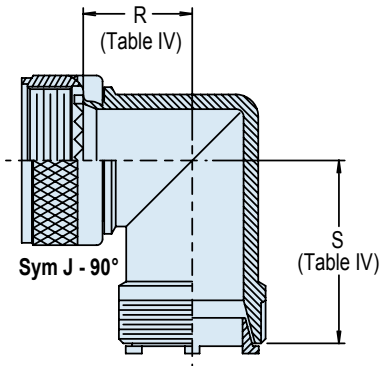
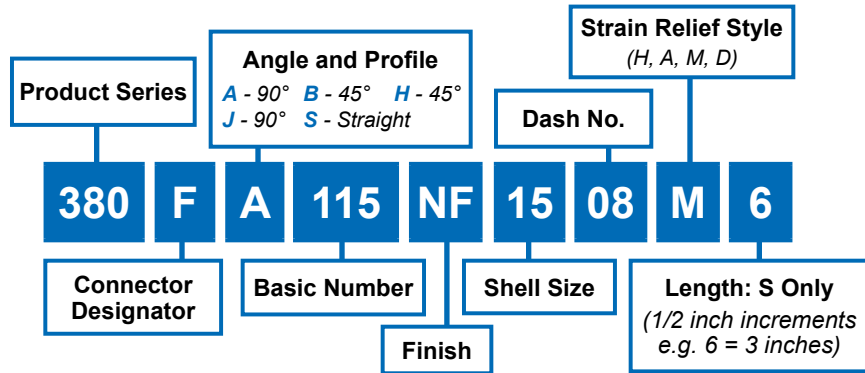

STYLE H
Heavy Duty
(Table X)

STYLE A
Medium Duty
(Table XI)

STYLE M
Medium Duty
(Table XI)

STYLE D
Medium Duty
(Table XI)

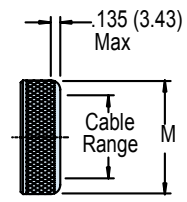
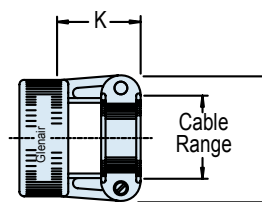
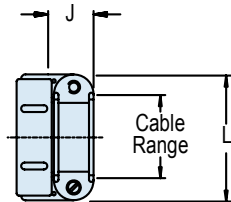
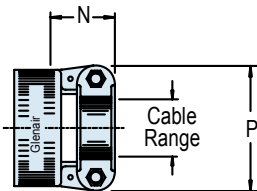

H

380-115
EMI/RFI Non-Environmental Backshell
with Strain Relief
Type B - Rotatable Coupling - Low Profile



TABLE III: ELBOW DIMENSIONS

Shell Size			C	D	E	F	R	S	T	U
A	F _L	H	Max	Max	Max	Max	Max	Max	Max	Max
08	08	09	.500 (12.7)	1.684 (42.8)	.457 (11.6)	1.674 (42.5)	.910 (23.11)	1.910 (48.77)	.780 (19.81)	1.780 (45.21)
10	10	11	.595 (15.1)	1.804 (45.8)	.520 (13.2)	1.734 (44.0)	.970 (24.64)	1.970 (50.04)	.810 (20.57)	1.810 (45.97)
12	12	13	.610 (15.5)	1.824 (46.3)	.582 (14.8)	1.794 (45.6)	1.030 (26.16)	2.030 (50.56)	.830 (21.08)	1.830 (46.48)
14	14	15	.700 (17.8)	1.894 (48.1)	.645 (16.4)	1.884 (47.9)	1.090 (27.68)	2.090 (53.09)	.850 (21.59)	1.850 (46.99)
16	16	17	.885 (22.5)	1.984 (50.4)	.738 (18.7)	1.994 (50.6)	1.150 (29.21)	2.150 (54.61)	.880 (22.35)	1.880 (47.75)
18	18	19	.975 (24.8)	2.154 (54.7)	.926 (23.5)	2.184 (55.5)	1.200 (30.48)	2.200 (55.88)	.900 (22.86)	1.900 (48.26)
20	20	21	.975 (24.8)	2.154 (54.7)	.926 (23.5)	2.184 (55.5)	1.270 (32.26)	2.270 (57.66)	.930 (23.62)	1.930 (49.02)
22	22	23	1.125 (28.6)	2.264 (57.5)	1.020 (25.9)	2.334 (59.3)	1.330 (33.78)	2.330 (59.18)	.950 (24.13)	1.950 (49.53)
24	24	25	1.125 (28.6)	2.264 (57.5)	1.020 (25.9)	2.334 (59.3)	1.390 (35.31)	2.390 (60.71)	.980 (24.13)	1.980 (50.29)
28			1.225 (31.1)	2.434 (61.8)	1.145 (29.1)	2.384 (60.6)	1.460 (37.08)	2.460 (62.48)	1.150 (29.21)	2.150 (54.61)
32			1.575 (40.0)	2.684 (68.2)	1.207 (30.7)	2.484 (63.1)	1.590 (40.38)	2.590 (65.79)	1.210 (30.73)	2.210 (56.13)
36			1.775 (45.1)	2.684 (68.2)	1.238 (31.4)	2.574 (65.4)	1.690 (42.93)	2.690 (68.33)	1.240 (31.50)	2.240 (56.90)
40			N/A	N/A	N/A	N/A	1.900 (48.26)	2.200 (55.88)	1.250 (31.75)	1.590 (40.38)
44			N/A	N/A	N/A	N/A	2.030 (51.56)	2.360 (59.94)	1.300 (33.02)	1.640 (41.65)
48			N/A	N/A	N/A	N/A	2.180 (53.37)	2.530 (64.26)	1.370 (34.79)	1.720 (43.68)
61			N/A	N/A	N/A	N/A	1.290 (32.76)	1.490 (37.85)	.880 (22.35)	1.100 (27.94)

TABLE II: FINISHES

Sym	Finish
B	Cadmium Plate, Olive Drab
C*	Anodize, Black
G*	Hard Coat, Anodic
J	Gold Iridite over Cadmium Plate over Nickel
LF	Cadmium Plate, Bright over Electroless Nickel
M	Electroless Nickel
N	Cadmium Plate, Olive Drab over Nickel
NC	Zinc Cobalt, Dark Olive Drab
NF	Cad/O.D. over Electroless Nickel (1000 Hr. Salt Spray)
T	Cadmium Plate, Bright Dip over Nickel
U**	Cadmium Plate, Black
UC	Zinc Cobalt, Black
Z1**	Passivate
ZN	Zinc Nickel, Olive Drab

TABLE IV: CABLE CLAMP CABLE RANGE

Dash No.	N Max	P Max	Cable Range	
			Min	Max
04	.780 (19.8)	.957 (24.3)	.125 (3.2)	.312 (7.9)
06	.780 (19.8)	1.145 (29.1)	.250 (6.4)	.437 (11.1)
08	.780 (19.8)	1.332 (33.8)	.312 (7.9)	.562 (14.3)
10	.780 (19.8)	1.332 (33.8)	.350 (8.9)	.625 (15.9)
12	.811 (20.6)	1.551 (39.4)	.500 (12.7)	.750 (19.1)
16	.905 (23.0)	1.770 (45.0)	.625 (15.9)	.937 (23.8)
20	1.092 (27.7)	2.113 (53.7)	.875 (22.2)	1.250 (31.8)
24	1.124 (28.5)	2.363 (60.0)	1.000 (25.4)	1.375 (34.9)
28	1.399 (35.5)	2.770 (70.4)	1.250 (31.8)	1.625 (41.3)
32	1.399 (35.5)	3.020 (76.7)	1.437 (36.5)	1.875 (47.6)

TABLE IV (Continued): CABLE CLAMP CABLE RANGE

Dash No.	W Max	X Max	Y Max	Z Max	Cable Range	
					Min**	Max
03*	.437 (11.1)	.760 (19.3)	.843 (21.4)	.630 (16.0)	.156 (4.0)	.250 (6.4)
04*	.437 (11.1)	.760 (19.3)	.906 (23.0)	.755 (19.2)	.188 (4.8)	.312 (7.9)
06	.500 (12.7)	.760 (19.3)	1.093 (27.8)	.942 (23.9)	.281 (7.1)	.438 (11.1)
08	.563 (14.3)	.760 (19.3)	1.187 (30.1)	1.067 (27.1)	.344 (8.7)	.562 (14.3)
10	.563 (14.3)	.760 (19.3)	1.281 (32.5)	1.192 (30.3)	.375 (9.5)	.625 (15.9)
12	.563 (14.3)	.760 (19.3)	1.500 (38.1)	1.380 (35.1)	.438 (11.1)	.750 (19.1)
16	.656 (16.7)	1.073 (27.3)	1.719 (43.7)	1.535 (39.0)	.562 (14.3)	.938 (23.8)
20	.656 (16.7)	1.323 (33.6)	2.062 (52.4)	1.848 (46.9)	.750 (19.1)	1.250 (31.8)
24	.656 (16.7)	1.323 (33.6)	2.312 (58.7)	2.255 (57.3)	.781 (19.8)	1.375 (34.9)
28	1.188 (30.2)	1.572 (39.9)	2.719 (69.1)	2.505 (63.6)	.969 (24.6)	1.625 (41.3)
32*	1.187 (30.1)	1.572 (39.9)	2.969 (75.4)	2.755 (70.0)	1.125 (28.6)	1.875 (47.6)
40*	1.125 (28.6)	1.572 (39.9)	3.531 (89.7)	3.255 (82.7)	1.469 (37.3)	2.375 (60.3)

* Not available in Style M clamp.

** Not Applicable Style D

APPLICATION NOTES

1. Assembly identified with manufacturer's name and part number, space permitting.
2. Standard minimum length for Style I is 1.500 inches, Style II standard length is 2.000 inches. For shorter lengths consult factory. Applies to Symbol S only.
3. When cable range exceeds Max Entry shown in Table IV, Style II will be supplied. Note: C, D, E, F, R, S, T and U dimensions do not apply to Style II.
4. Metric dimensions are in parentheses.
5. For effective grounding, connector with conductive finish should be used.
6. Glenair Series 600 Backshell Assembly Tools are recommended for assembly and installation.
7. Material/Finish:
Elbow, adapter, coupling nut, ferrules and clamp - Aluminum alloy or SST/Table II.
Hardware - CRES/Passivate
8. Angular functions A and B are currently not available in shell sizes 40, 44 and 61. Consult factory for suitable alternatives.

**CONNECTOR
DESIGNATORS**

F-H

**SELF-LOCKING
ROTATABLE
COUPLING**

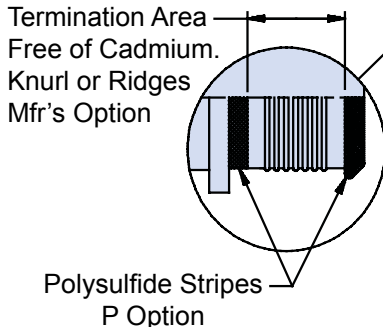
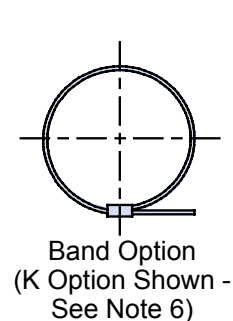
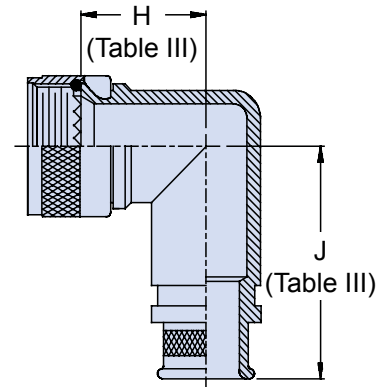
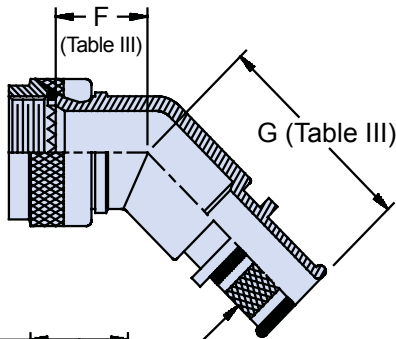
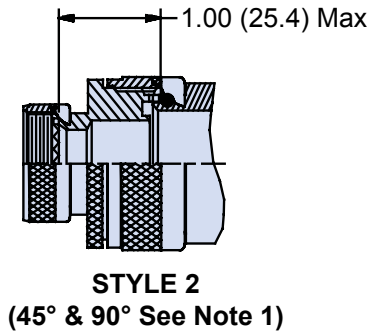
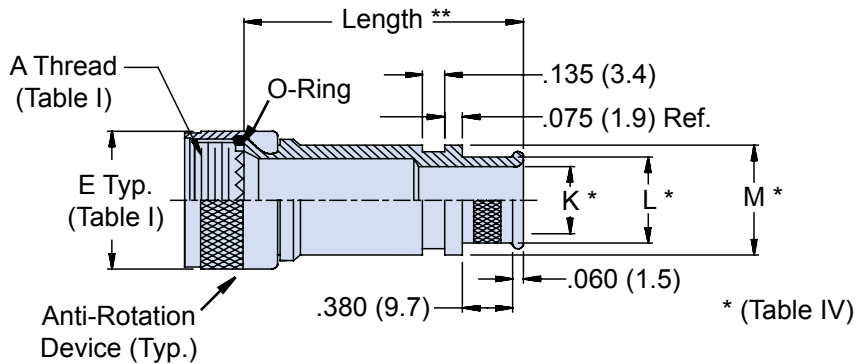
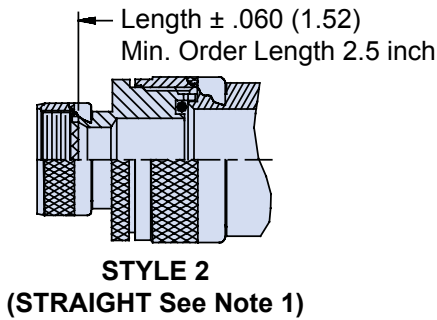
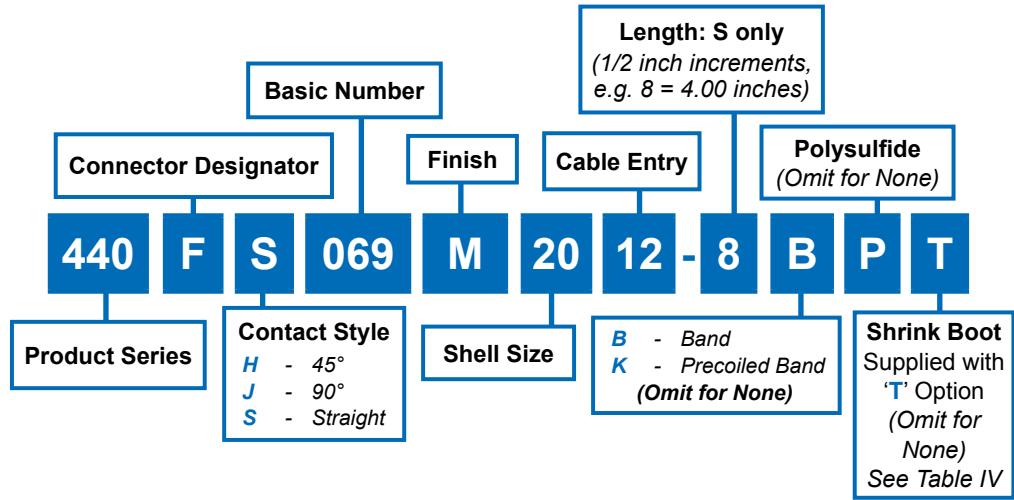

** Length ± .060 (1.52)
Min. Order Length 2.0 inch
(See Note 4)

440-069

EMI/RFI Banding and Shrink Boot Adapter Self-Locking Rotatable Coupling - Standard Profile

**Connector
Accessories**
TABLE III: ELBOW DIMENSIONS

Shell Size		F Max	G Max	H Max	J Max
Conn. Desig. A-F-L	H				
08	09	.806 (20.5)	1.038 (26.4)	.906 (23.0)	1.146 (29.1)
10	11	.832 (21.1)	1.064 (27.0)	.966 (24.5)	1.210 (30.7)
12	13	.856 (21.7)	1.088 (27.6)	1.026 (26.1)	1.268 (32.2)
14	15	.882 (22.4)	1.114 (28.3)	1.076 (27.3)	1.330 (33.8)
16	17	.908 (23.1)	1.150 (29.2)	1.136 (28.9)	1.392 (35.4)
18	19	.927 (23.5)	1.190 (30.2)	1.176 (29.9)	1.438 (36.5)
20	21	.953 (24.2)	1.250 (31.8)	1.236 (31.4)	1.500 (38.1)
22	23	.979 (24.9)	1.320 (33.5)	1.296 (32.9)	1.562 (39.7)
24	25	1.004 (25.5)	1.380 (35.1)	1.356 (34.4)	1.625 (41.3)
28		1.197 (30.4)	1.500 (38.1)	1.422 (36.1)	1.654 (42.0)
32		1.280 (32.5)	1.620 (41.1)	1.545 (39.2)	1.777 (45.1)
36		1.294 (32.9)	1.750 (44.5)	1.652 (42.0)	1.844 (46.8)
40		1.320 (33.5)	1.870 (47.5)	1.960 (49.8)	2.070 (52.6)

- When maximum cable entry is exceeded, Style 2 will be supplied. Dimensions F, G, H and J will not apply. Please consult factory.
- Metric dimensions (mm) are indicated in parentheses.
- Interface O-Ring not supplied with Connector Designator A.
- Consult factory for shorter lengths on straight backshells.
- See G-5 for Shrink Boot Reference Information.
- Backshells supplied with 600-052-* band, see Glenair Series 600 Tool Catalog for installation.

TABLE IV: CABLE ENTRY

Dash No.	K	L	M	Shrink Boot *
01	.125 (3.2)	.250 (6.4)	.312 (7.9)	770-003S111
31	.188 (4.8)	.312 (7.9)	.374 (9.5)	770-003S111
02	.250 (6.4)	.375 (9.5)	.437 (11.1)	770-003S112
32	.312 (7.9)	.438 (11.1)	.500 (12.7)	770-003S112
03	.375 (9.5)	.500 (12.7)	.562 (14.3)	770-003S112
33	.438 (11.1)	.562 (14.3)	.624 (15.8)	770-001S104
04	.500 (12.7)	.625 (15.9)	.687 (17.4)	770-001S104
34	.562 (14.3)	.688 (17.5)	.750 (19.1)	770-001S104
05	.625 (15.9)	.750 (19.1)	.812 (20.6)	770-001S104
35	.688 (17.5)	.812 (20.6)	.874 (22.2)	770-001S104
06	.750 (19.1)	.875 (22.2)	.937 (23.8)	770-001S105
36	.812 (20.6)	.938 (23.8)	1.000 (25.4)	770-001S105
07	.875 (22.2)	1.000 (25.4)	1.062 (27.0)	770-001S105
37	.938 (23.8)	1.062 (27.0)	1.124 (28.5)	770-001S105
08	1.000 (25.4)	1.125 (28.6)	1.187 (30.1)	770-001S106
38	1.062 (27.0)	1.188 (30.2)	1.250 (31.8)	770-001S107
09	1.125 (28.6)	1.250 (31.8)	1.312 (33.3)	770-001S107
10	1.250 (31.8)	1.375 (34.9)	1.437 (36.5)	770-001S107
11	1.375 (34.9)	1.500 (38.1)	1.562 (39.7)	770-001S107
12	1.500 (38.1)	1.625 (41.3)	1.687 (42.8)	770-001S108
13	1.625 (41.3)	1.750 (44.5)	1.812 (46.0)	770-001S108
14	1.750 (44.5)	1.875 (47.6)	1.937 (49.2)	770-001S109
15	1.875 (47.6)	2.000 (50.8)	2.062 (52.4)	770-001S109
16	2.000 (50.8)	2.125 (54.0)	2.187 (55.5)	

* Glenair Shrink Boot Supplied with "T" Option
(see Part Number Development)

TABLE II: FINISHES

Symbol	Finish
B	Cadmium Plate, Olive Drab
C	Anodize, Black
GB	Black Anodize, Hard Coat
M	Electroless Nickel
N	Cad Plate, Olive Drab over Electroless Nickel
NF	Cadmium Plate, Olive Drab over Electroless Nickel
MT	Ni-PTFE 1000 Hour Grey™ Nickel Fluorocarbon Polymer
Z1	Stainless Steel Passivate
ZL	CRES, Electroless Nickel
ZN	Zinc-Nickel

Connector Designators:

MIL-DTL-38999 Series I, II (F)
MIL-DTL-38999 Series III and IV (H)

F-H
ROTATABLE
COUPLING

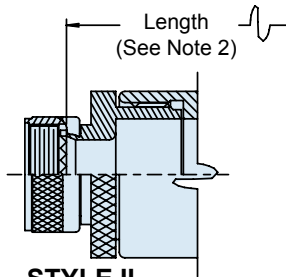
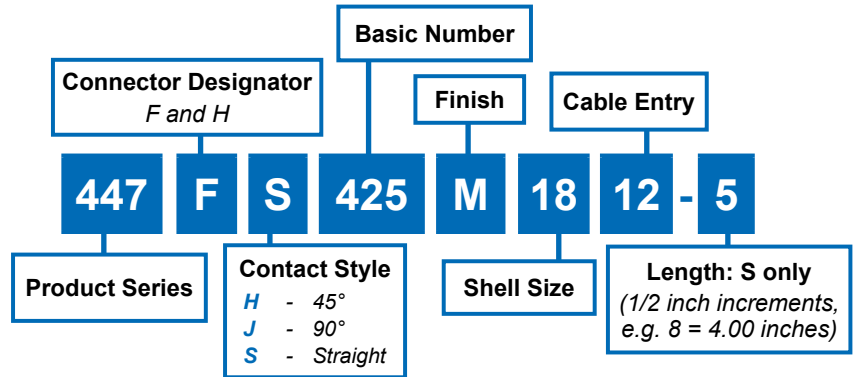

STYLE II
(See Note 3)
STRAIGHT

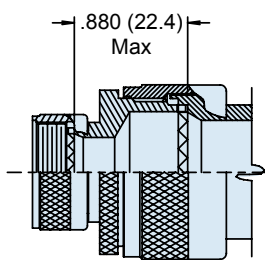
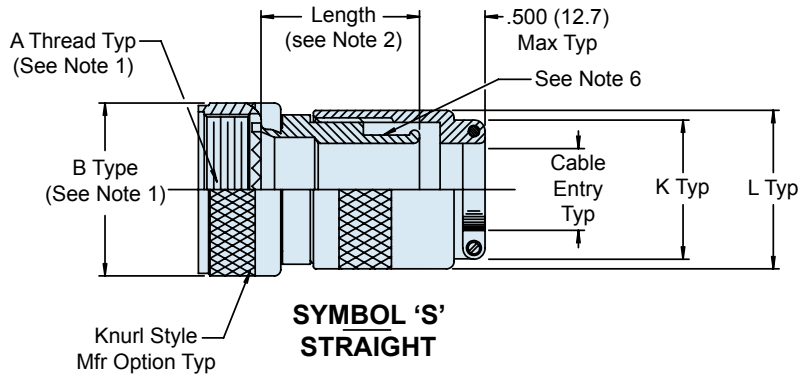

SYMBOL J
90°

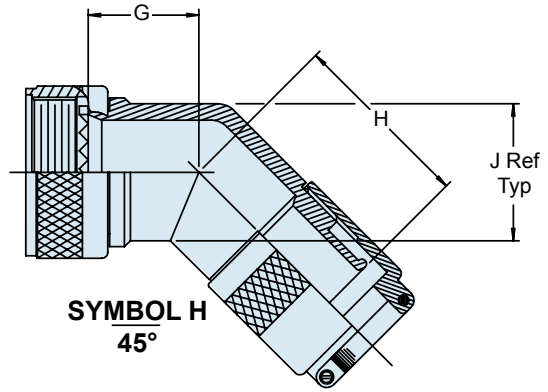
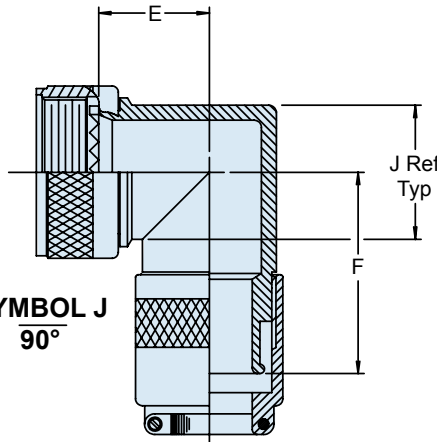

APPLICATION NOTES

- Standard minimum length for Style I is 1 inch (25.4), Style II is 1.5 inches (38.1). Consult factory about shorter lengths (Note: Applies to Symbol S Straight only).
- When cable diameter exceeds "Max Dash No" in Table I, Style II will be supplied.
- For effective grounding, connector with conductive finish should be used.
- Glenair Series 600 Backshell Assembly tools are recommended for assembly and installation.
- For shield termination see Glenair Drawings 600-050 and 600-052.
- Material/Finish:
Adapters, Elbows, Coupling Nuts, Ferrule, Clamp - Al Alloy/See Table I
Hardware - Cres/Passivate
- Metric dimensions (mm) are indicated in parentheses.

447-425
**EMI/RFI Non-Environmental Band-in-a-Can Backshell
 With Cable Clamp Strain-Relief
 Rotatable Coupling - Standard Profile**



Connector
 Accessories

TABLE III: BACKSHELL DIMENSIONS (Continued Below)

Shell Size									
A,F,L,S	H	E Max.	F Max.	G Max.	H Max.	M Max.	N Max.	P Max.	
08	09	.639 (16.23)	1.380 (35.05)	.750 (19.05)	1.500 (38.10)	.817 (20.75)	1.057 (26.85)	1.125 (28.58)	
10	11	.664 (16.87)	1.410 (35.81)	.810 (20.57)	1.550 (39.37)	.861 (21.87)	1.111 (28.22)	1.250 (31.75)	
12	13	.688 (17.48)	1.430 (36.32)	.870 (22.10)	1.610 (40.89)	.911 (23.14)	1.161 (29.49)	1.375 (34.93)	
14	15	.705 (17.91)	1.460 (37.08)	.920 (23.37)	1.680 (42.67)	.965 (24.51)	1.215 (30.86)	1.500 (38.10)	
16	17	.732 (18.59)	1.480 (37.59)	.980 (24.89)	1.740 (44.20)	1.264 (32.11)	1.625 (41.28)	1.875 (47.63)	
18	19	.748 (19.00)	1.490 (37.85)	1.020 (25.91)	1.760 (44.70)	1.064 (27.03)	1.314 (33.38)	1.750 (44.45)	
20	21	.773 (19.63)	1.510 (38.35)	1.080 (27.43)	1.820 (46.23)	1.118 (28.40)	1.368 (34.75)	1.875 (47.63)	
22	23	.800 (20.32)	1.550 (39.37)	1.140 (28.96)	1.900 (48.26)	1.172 (29.77)	1.422 (36.12)	2.000 (50.80)	
24	25	.823 (20.90)	1.580 (40.13)	1.200 (30.48)	1.970 (50.04)	1.221 (31.01)	1.471 (37.36)	2.125 (53.98)	
28		.930 (23.62)	1.610 (40.89)	1.380 (35.05)	2.000 (40.80)	1.271 (32.28)	1.522 (38.66)	2.250 (57.15)	
32		.980 (24.89)	1.610 (40.89)	1.500 (38.10)	2.000 (40.80)	1.375 (34.93)	1.626 (41.30)	2.500 (63.50)	
36		1.040 (26.42)	1.610 (40.89)	1.620 (41.15)	2.040 (51.82)	TBD	TBD	TBD	
40		1.100 (27.94)	1.610 (40.89)	1.740 (44.20)	2.150 (54.61)	TBD	TBD	TBD	
44		1.150 (29.21)	1.610 (40.89)	1.870 (47.50)	2.280 (57.91)	TBD	TBD	TBD	
48		1.200 (30.48)	1.640 (41.66)	1.990 (50.55)	2.400 (60.96)	TBD	TBD	TBD	
61		.880 (22.35)	1.580 (40.13)	1.260 (32.00)	1.970 (50.04)	1.221 (31.01)	1.417 (35.99)	2.125 (53.98)	

TABLE III: BACKSHELL DIMENSIONS (Continued From Above)

Shell Size											Function C Max. Wire Bundle
A,F,L,S	H	R Max.	S Max.	T Max.	U Max.	V Max.	W Max.	Y Max.	Z Ref.		
08	09	1.375 (34.93)	.520 (13.21)	1.840 (46.74)	.680 (17.27)	1.780 (45.21)	.681 (17.30)	2.120 (53.85)	.340 (8.64)	.250 (6.35)	
10	11	1.500 (38.10)	.520 (13.21)	1.900 (48.26)	.750 (19.05)	1.840 (46.74)	.731 (18.57)	2.280 (57.91)	.270 (6.86)	.375 (9.53)	
12	13	1.625 (41.28)	.560 (14.22)	1.970 (50.04)	.810 (20.57)	1.910 (48.51)	.731 (18.57)	2.280 (57.91)	.270 (6.86)	.375 (9.53)	
14	15	1.750 (44.45)	.620 (15.75)	2.000 (50.80)	.870 (22.10)	1.940 (49.28)	.831 (21.11)	2.350 (59.69)	.280 (7.11)	.500 (12.70)	
16	17	.680 (17.27)	2.100 (53.34)	.930 (23.62)	2.040 (51.82)	2.040 (51.82)	.981 (24.92)	2.400 (60.96)	.420 (10.67)	.625 (15.88)	
18	19	2.000 (40.80)	.750 (19.05)	2.160 (54.86)	1.000 (25.40)	2.100 (53.34)	1.181 (30.00)	2.430 (61.72)	.640 (16.26)	.625 (15.88)	
20	21	2.125 (53.98)	.820 (20.83)	2.220 (56.39)	1.060 (26.92)	2.160 (54.86)	1.181 (30.00)	2.430 (61.72)	.640 (16.26)	.625 (15.88)	
22	23	2.250 (57.15)	.880 (22.35)	2.280 (57.91)	1.120 (28.45)	2.220 (56.39)	1.181 (30.00)	2.580 (65.53)	.540 (13.72)	.750 (19.05)	
24	25	2.375 (60.33)	.940 (23.88)	2.340 (59.44)	1.180 (29.97)	2.280 (57.91)	1.181 (30.00)	2.580 (65.53)	.540 (13.72)	.750 (19.05)	
28		2.500 (63.50)	1.090 (27.69)	2.460 (62.48)	1.340 (34.04)	2.450 (62.23)	TBD	TBD	TBD	TBD	
32		2.750 (69.85)	TBD	TBD	TBD	TBD	TBD	TBD	TBD	TBD	
36		TBD	TBD	TBD	1.590 (40.39)	2.680 (68.07)	TBD	TBD	TBD	TBD	
40		TBD	TBD	TBD	1.720 (43.69)	2.890 (73.41)	TBD	TBD	TBD	TBD	
44		TBD	TBD	TBD	TBD	TBD	TBD	TBD	TBD	TBD	
48		TBD	TBD	TBD	TBD	TBD	TBD	TBD	TBD	TBD	
61		2.375 (60.33)	.940 (23.88)	TBD	1.180 (29.97)	2.290 (58.17)	1.181 (30.00)	2.580 (65.53)	.540 (13.72)	.750 (19.05)	

TABLE IV: CABLE ENTRY

Dash No.	K Max.	L Max.	Cable Entry	
			Min.	Max.
10	.220 (5.6)	.1000 (25.4)	.130 (3.3)	.250 (6.4)
12	.310 (7.9)	1.250 (31.8)	.250 (6.4)	.380 (9.7)
14	.440 (11.2)	1.340 (34.0)	.310 (7.9)	.440 (11.2)
16	.560 (14.2)	1.470 (37.3)	.375 (9.5)	.630 (16.0)
18	.630 (16.0)	1.560 (39.6)	.560 (14.2)	.960 (17.5)
20	.750 (19.1)	1.620 (41.1)	.630 (16.0)	.750 (19.1)
22	.880 (22.4)	1.750 (44.5)	.750 (19.1)	.880 (22.4)
24	1.000 (25.4)	1.870 (47.5)	.880 (22.4)	1.000 (25.4)
28	1.060 (26.9)	1.970 (50.0)	1.000 (25.4)	1.130 (28.7)
32	1.190 (30.2)	2.090 (53.1)	1.130 (28.7)	1.250 (31.8)

TABLE II: FINISHES

Symbol	Finish
B	Cadmium Plate, Olive Drab
C	Anodize, Black
GB	Black Anodize, Hard Coat
M	Electroless Nickel
N	Cad Plate, Olive Drab over Electroless Nickel
NF	Cadmium Plate, Olive Drab over Electroless Nickel
MT	Ni-PTFE 1000 Hour Grey™ Nickel Fluorocarbon Polymer
Z1	Stainless Steel Passivate
ZL	CRES, Electroless Nickel
ZN	Zinc-Nickel

H



620-048
Strain Relief
Self-Locking Rotatable Coupling - Straight and 90°

**CONNECTOR
DESIGNATOR**

MIL-DTL-38999 Series I, II (F)
MIL-DTL-38999 Series III and IV (H)

F-H

**SELF-LOCKING
ROTATABLE
COUPLING**

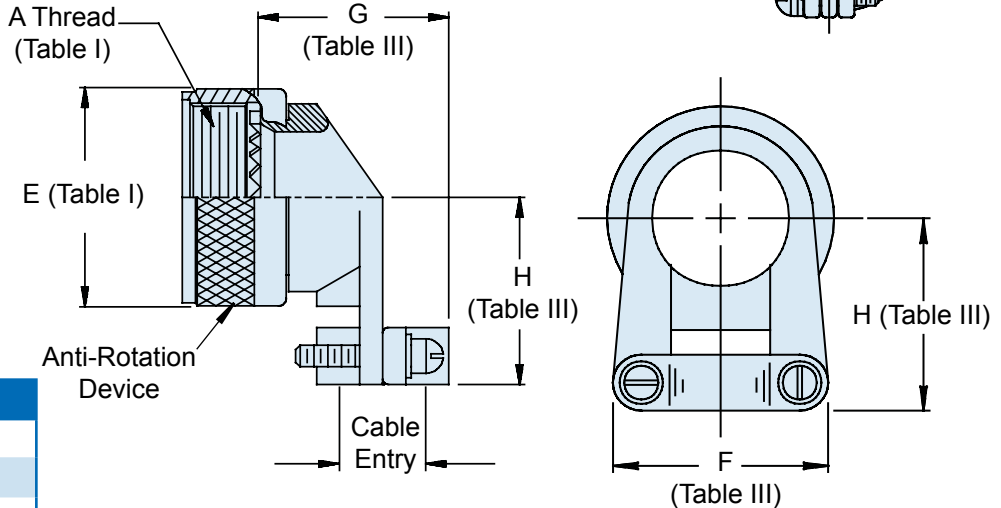
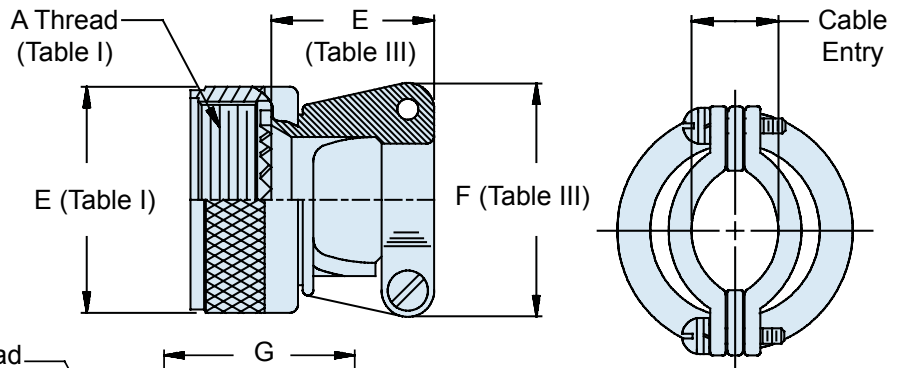
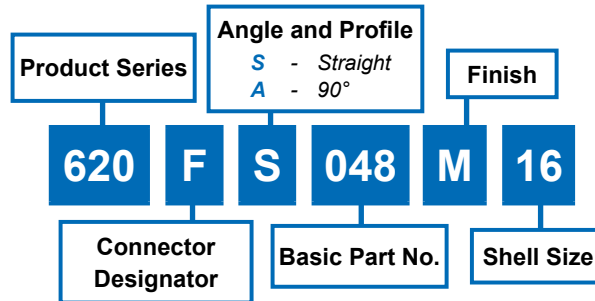

APPLICATION NOTES

1. Cable range is defined as the accommodation range for the wire bundle or cable. Dimensions shown are not intended for inspection criteria.
2. Metric dimensions (mm) are indicated in parentheses.

TABLE II: FINISHES

Symbol	Finish
B	Cadmium Plate, Olive Drab
C	Anodize, Black
G	Hard Coat, Anodic
GB	Black Anodize, Hard Coat
M	Electroless Nickel
N	Cad Plate, Olive Drab over Electroless Nickel
NF	Cadmium Plate, Olive Drab over Electroless Nickel
MT	Nickel Fluorocarbon Polymer
Z1	Stainless Steel Passivate
ZN	Zinc-Nickel

TABLE III: CABLE ENTRY

Shell Size	Cable Range		G Max	H Max	Cable Range Closed	Cable Range Open
	E Max	F Max				
08/09	.830 (21.1)	.780 (19.8)	.704 (17.9)	.808 (20.5)	.098 (2.5)	.234 (5.9)
10/11	.850 (21.6)	.832 (21.1)	.786 (20.0)	.867 (22.0)	.153 (3.9)	.234 (5.9)
12/13	.900 (22.9)	.988 (25.1)	.979 (24.9)	.929 (23.6)	.190 (4.8)	.328 (8.3)
14/15	.900 (22.9)	1.046 (26.6)	1.039 (26.4)	.992 (25.2)	.260 (6.6)	.457 (11.6)
16/17	.940 (23.9)	1.319 (33.5)	1.188 (30.2)	1.056 (26.8)	.283 (7.2)	.614 (15.6)
18/19	1.020 (25.9)	1.451 (36.9)	1.300 (33.0)	1.233 (31.3)	.325 (8.3)	.634 (16.1)
20/21	1.070 (27.2)	1.557 (39.5)	1.425 (36.2)	1.296 (32.9)	.343 (8.7)	.698 (17.7)
22/23	1.190 (30.2)	1.653 (42.0)	1.550 (39.4)	1.358 (34.5)	.381 (9.7)	.823 (20.9)
24/25	1.220 (31.0)	1.775 (45.1)	1.675 (42.5)	1.420 (36.1)	.418 (10.6)	.853 (21.7)

620-049
Strain Relief
Self-Locking Rotatable Coupling - 45°



**CONNECTOR
DESIGNATOR**

MIL-DTL-38999 Series I, II (F)
MIL-DTL-38999 Series III and IV (H)

F-H

SELF-LOCKING

**ROTATABLE
COUPLING**

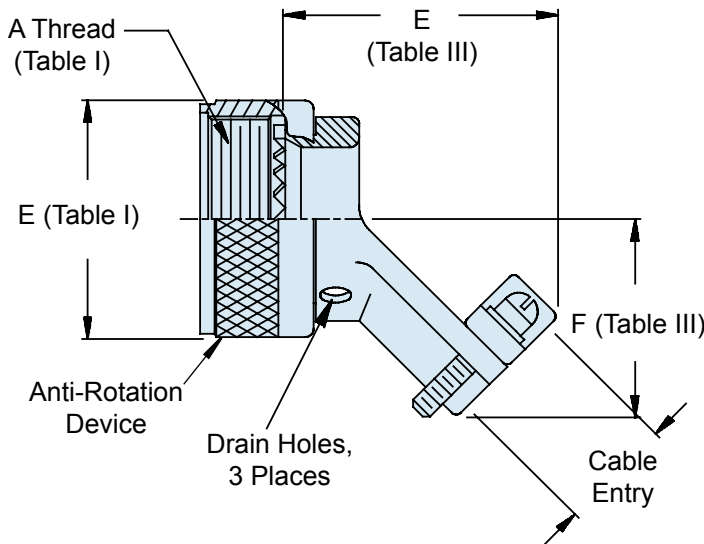
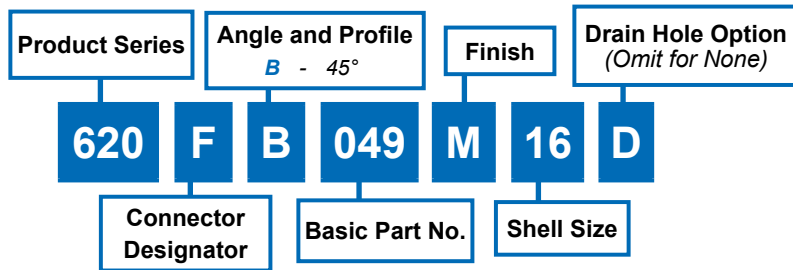

TABLE II: FINISHES	
Symbol	Finish
B	Cadmium Plate, Olive Drab
C	Anodize, Black
GB	Black Anodize, Hard Coat
M	Electroless Nickel
N	Cad Plate, Olive Drab over Electroless Nickel
NF	Cadmium Plate, Olive Drab over Electroless Nickel
MT	Ni-PTFE 1000 Hour Grey™ Nickel Fluorocarbon Polymer
Z1	Stainless Steel Passivate
ZN	Zinc-Nickel

TABLE III: CABLE ENTRY				
Shell Size	E Max	F Max	Cable Range	
			Closed	Open
08/09	1.536 (39.0)	.730 (18.5)	.125 (3.2)	.204 (5.2)
10/11	1.566 (39.8)	.810 (20.6)	.187 (4.7)	.286 (7.3)
12/13	1.646 (41.8)	.870 (22.1)	.291 (7.4)	.416 (10.6)
14/15	1.686 (42.8)	.930 (23.6)	.351 (8.9)	.476 (12.1)
16/17	1.796 (45.6)	.990 (25.1)	.501 (12.7)	.626 (15.9)
18/19	1.906 (48.4)	1.110(28.2)	.518 (13.2)	.706 (17.9)
20/21	1.956 (49.7)	1.170 (29.7)	.581 (14.8)	.831 (21.1)
22/23	1.996 (50.7)	1.240 (31.5)	.644 (16.4)	.956 (24.3)
24/25	2.046 (52.0)	1.300 (33.0)	.706 (17.9)	1.081 (27.5)

APPLICATION NOTES

1. Cable range is defined as the accommodation range for the wire bundle or cable. Dimensions shown are not intended for inspection criteria.
2. Metric dimensions (mm) are indicated in parentheses.





627-122
Composite Self-Locking Rotatable Coupling
Swing-Arm Strain Relief
for Connector Designators F & H

**CONNECTOR
DESIGNATOR**

MIL-DTL-38999 Series I, II (F)
MIL-DTL-38999 Series III and IV (H)

F-H

SELF-LOCKING

**ROTATABLE
COUPLING**

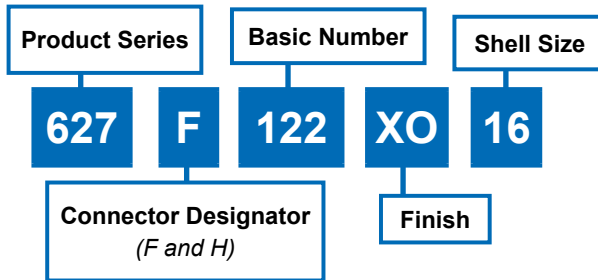

U.S. PATENT NO. 6419519

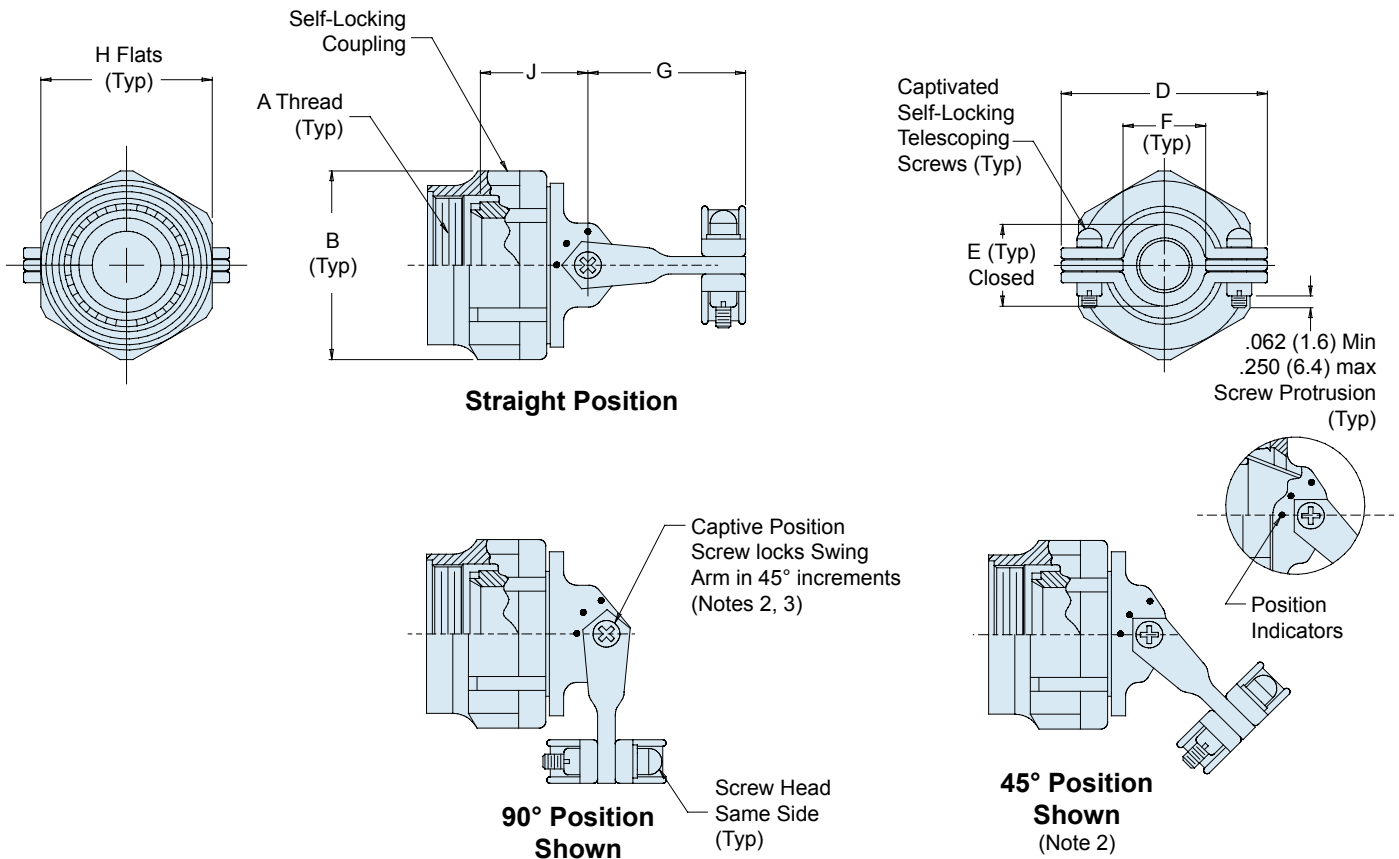

H

627-122
Composite Self-Locking Rotatable Coupling
Swing-Arm Strain Relief
for Connector Designators F & H



TABLE II: FINISHES

Symbol	Finish
XO	Composite Material, No Plating, Color Black and Brown, Brass Interface Shroud and Adapter - Nickel Plated

TABLE III: CONNECTOR SHELL SIZE ORDER NUMBER

Shell Size for Connector Designator		B Dia Max	D Max	E ±.06 (1.5)	F Min	G Max	H Flats		J ±.03 (0.8)
F	H						Max	Min	
08	09	.812 (20.6)	.980 (24.9)	.265 (6.7)	.220 (5.9)	1.060 (26.9)	.750 (19.1)	.736 (18.7)	.880 (22.4)
10	11	.938 (23.8)	1.050 (26.7)	.310 (7.9)	.270 (6.9)	1.090 (27.7)	.875 (22.2)	.860 (21.8)	.910 (23.1)
12	13	1.125 (28.6)	1.200 (30.5)	.390 (9.9)	.350 (8.9)	1.180 (30.0)	1.000 (25.4)	.980 (24.9)	.950 (24.1)
14	15	1.250 (31.8)	1.300 (33.0)	.506 (12.9)	.470 (11.9)	1.240 (31.5)	1.125 (28.6)	1.100 (27.9)	1.010 (25.7)
16	17	1.375 (34.9)	1.440 (36.6)	.591 (15.0)	.550 (14.0)	1.320 (33.5)	1.250 (31.8)	1.224 (31.1)	1.050 (26.7)
18	19	1.500 (38.1)	1.560 (39.6)	.661 (16.8)	.620 (15.7)	1.390 (35.3)	1.375 (34.9)	1.469 (37.3)	1.080 (30.0)
20	21	1.625 (41.3)	1.690 (42.9)	.744 (18.9)	.700 (17.8)	1.550 (39.4)	1.500 (38.1)	1.500 (38.1)	1.120 (28.4)
22	23	1.750 (44.5)	1.770 (45.0)	.826 (21.0)	.780 (19.8)	1.550 (39.4)	1.625 (41.3)	1.581 (40.2)	1.160 (29.5)
24	25	1.875 (47.6)	1.890 (48.0)	.896 (22.8)	.850 (21.6)	1.610 (40.9)	1.750 (44.5)	1.960 (49.8)	1.200 (30.5)

Consult factory for additional entry sizes available.

APPLICATION NOTES

- Glenair series 600 Backshell assembly Tools are recommended for assembly and installation.
- Swing Arm locks in 45° increments—Sizes 08 thru 24, additional positioning increments are manufacturer's option.
- Captive Screw can remain engaged to the body when positioning the Arm. When tightened, the screw shall not protrude into the inside surfaces.
- Metric dimensions (mm) are indicated in parentheses.



687-207
Composite MIL-C-85049/93
Banding Split-Ring

**For Use
with Glenair
Banding
Backshells and
Braid Socks**

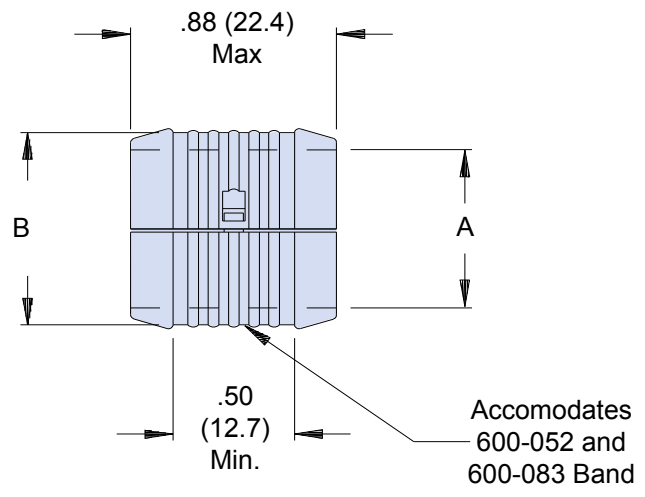
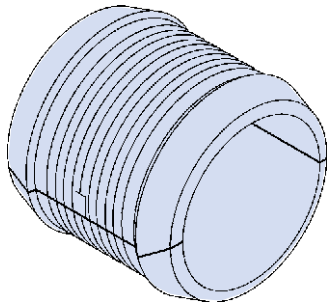

EXAMPLE PART NUMBER:

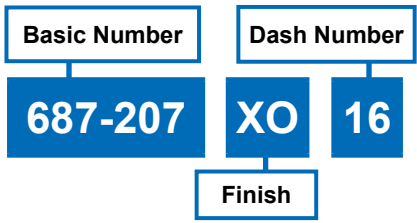
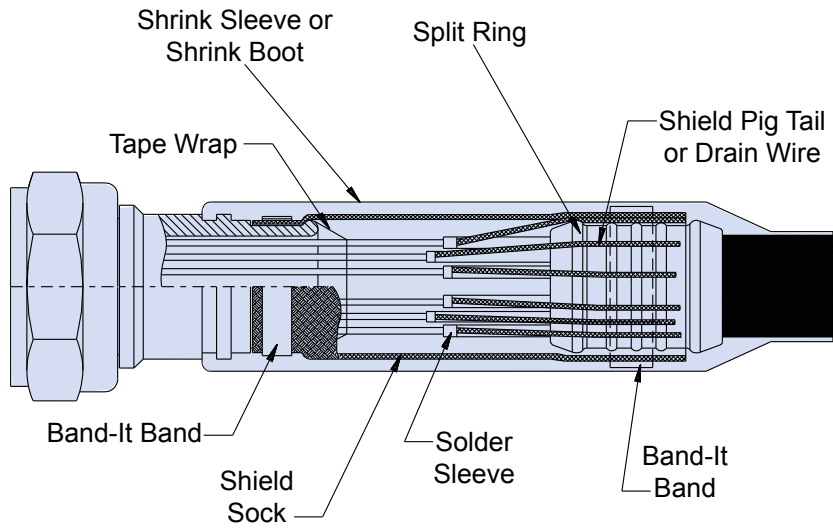

TABLE I: DASH NUMBER

Dash No.	A Diameter		B Diameter	
	± .03	(0.8)	± .03	(0.8)
04	.25	(6.4)	.36	(9.1)
06	.38	(9.7)	.49	(12.4)
08	.50	(12.7)	.61	(15.5)
10	.63	(16.0)	.74	(18.8)
12	.75	(19.1)	.86	(21.8)
14	.88	(22.4)	.99	(25.1)
16	1.00	(25.4)	1.10	(27.9)
18	1.13	(28.7)	1.24	(31.5)
20	1.25	(31.8)	1.36	(34.5)
22	1.38	(35.1)	1.49	(37.8)
24	1.50	(38.1)	1.61	(40.9)
26	1.63	(41.4)	1.74	(44.2)
28	1.75	(44.5)	1.86	(47.2)

EXAMPLE APPLICATION



H

103-026 and -027
100% AmberStrand® Composite Braid
and 75% / 25% AmberStrand®/Nickel Copper Braid
for EMI Shielding Applications

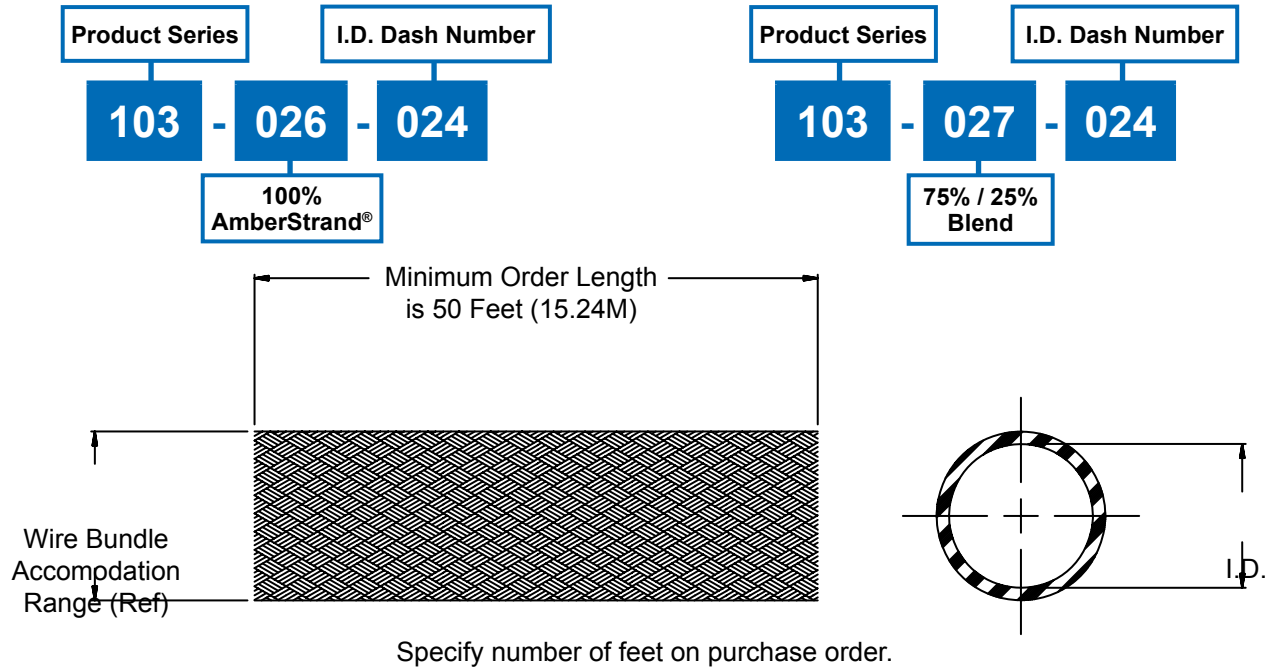

103-026 (100% AmberStrand®)			
Dash Number	Nominal I.D.	Wire Bundle Range	Approximate Grams Per Foot
004	.125 (3.2)	.093 (2.4)	1.0
		.140 (3.5)	
008	.250 (6.4)	.125 (3.2)	1.8
		.312 (7.9)	
012	.375 (9.5)	.250 (6.4)	2.3
		.437 (11.1)	
016	.500 (12.7)	.250 (6.4)	3.0
		.590 (15.0)	
020	.625 (15.9)	.375 (9.5)	4.4
		.700 (17.8)	
024	.750 (19.1)	.500 (12.7)	5.2
		.830 (21.1)	
032	1.000 (25.4)	.780 (19.8)	8.0
		1.100 (27.94)	
040	1.250 (31.8)	.938 (23.8)	10.0
		1.312 (33.3)	
048	1.500 (38.1)	1.187 (30.1)	15.2
		1.590 (40.37)	
064	2.000 (50.8)	1.312 (33.3)	22.0
		2.090 (50.8)	

103-027 (75% AmberStrand® and 25% Nickel Copper)			
Dash Number	Nominal I.D.	Wire Bundle Range	Approximate Grams Per Foot
004	.125 (3.2)	.093 (2.4)	1.5
		.140 (3.5)	
008	.250 (6.4)	.125 (3.2)	2.4
		.312 (7.9)	
012	.375 (9.5)	.250 (6.4)	3.9
		.437 (11.1)	
016	.500 (12.7)	.250 (6.4)	5.4
		.590 (15.0)	
020	.625 (15.9)	.375 (9.5)	6.4
		.700 (17.8)	
024	.750 (19.1)	.500 (12.7)	7.2
		.830 (21.1)	
032	1.000 (25.4)	.780 (19.8)	11.0
		1.100 (27.94)	
040	1.250 (31.8)	.938 (23.8)	15.0
		1.312 (33.3)	
048	1.500 (38.1)	1.187 (30.1)	25.2
		1.590 (40.37)	
064	2.000 (50.8)	1.312 (33.3)	32.0
		2.090 (50.8)	

Metric dimensions (mm) are indicated in parentheses.





100-001 Tubular Metal Braid QQ-B-575B ASTM B33 Tin Coated Copper for EMI Shielding Applications

Product Series	Dash Number
100-001	A 203 L
A = 36 AWG (Table I) B = 34 AWG (Table II)	Lanyard (Omit for None)

Specify number of feet on purchase order.

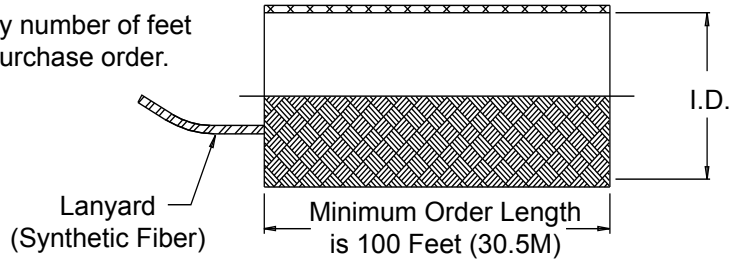

TABLE I: (36 AWG)

Dash No.	Fractional Equivalent	Nominal I.D.	No. of Carriers	No. of Ends	Current Rating Amps	Lbs./100 Ft. (Kg/30.5M)	Federal Specification No.
031	1/32	.031 (0.8)	24	24	7.0	.20 (.09)	QQB575R36T031
062	1/16	.062 (1.6)	24	48	11.0	.40 (.18)	QQB575R36T062
078	5/64	.078 (2.0)	24	72	16.0	.60 (.27)	QQB575R36T078
109	7/64	.109 (2.8)	24	96	19.0	.83 (.38)	QQB575R36T109
125	1/8	.125 (3.2)	24	120	25.0	1.03 (.47)	QQB575R36T125
156	5/32	.156 (4.0)	24	240	40.0	2.09 (.95)	QQB575R36T156
171	11/64	.171 (4.3)	24	168	32.0	1.43 (.65)	QQB575R36T171
188	3/16	.188 (4.8)	24	192	33.0	1.63 (.74)	--
203	13/64	.203 (5.2)	24	312	46.0	2.80 (1.27)	QQB575R36T203
250	1/4	.250 (6.4)	24	384	53.0	3.45 (1.56)	QQB575R36T250
375	3/8	.375 (9.5)	48	384	53.0	3.95 (1.79)	QQB575R36T375
500	1/2	.500 (12.7)	48	528	62.0	4.77 (2.16)	QQB575R36T500
562	9/16	.562 (14.3)	48	624	73.0	5.00 (2.27)	--
625	5/8	.625 (15.9)	48	720	85.0	5.94 (2.69)	--
781	25/32	.781 (19.8)	48	864	88.0	7.35 (3.33)	QQB575R36T781
937	15/16	.937 (23.8)	64	640	65.0	5.83 (2.64)	--
1000	1	1.000 (25.4)	64	768	90.0	7.50 (3.40)	--
1250	1 1/4	1.250 (31.8)	72	792			
1375	1 3/8	1.375 (34.9)	72	864			
1500	1 1/2	1.500 (38.1)	72	936			
2000	2	2.000 (50.8)	96	1152			
2500	2 1/2	2.500 (63.5)	96	1248			

TABLE II: (34 AWG)

Dash No.	Fractional Equivalent	Nominal I.D.	No. of Carriers	No. of Ends	Current Rating Amps	Lbs./100 Ft. (Kg/30.5M)	Federal Specification No.
062	1/16	.062 (1.6)	16	32	11.0	.43 (.20)	QQB575R34T062
109	7/64	.109 (2.8)	16	64	19.0	.82 (.37)	QQB575R34T109
125	1/8	.125 (3.2)	24	72	19.0	.92 (.42)	QQB575R34T125
171	11/64	.171 (4.3)	24	120	36.0	1.56 (.71)	QQB575R34T171
203	13/64	.203 (5.2)	24	192	46.0	2.79 (1.27)	QQB575R34T203
375	3/8	.375 (9.5)	48	240	53.0	3.27 (1.48)	QQB575R34T375
437	7/16	.437 (11.1)	48	288	44.2	3.93 (1.78)	--
500	1/2	.500 (12.7)	48	336	62.0	4.77 (2.16)	QQB575R34T500
781	25/32	.781 (19.8)	48	528	88.0	7.14 (3.24)	QQB575R34T781

APPLICATION NOTES

- | | |
|---|--|
| 1. Glenair series 600 Backshell assembly tools are recommended for assembly and installation.
2. Swing Arm locks in 45° increments—Sizes 08 thru 24, additional positioning increments are manufacturer's option.
3. Captive Screw remains engaged to the body when positioning the Arm. When tightened, the Screw shall not protrude into the inside surfaces. | 4. Fits Connector Designators: MIL-DTL-38999 Series I, II (F), MIL-DTL-38999 Series III and IV (H), MIL-DTL-5015 (A), and MIL-DTL-26482 (A)
5. Metric Dimensions (mm) are indicated in parentheses. |
|---|--|

100-003
Tubular Metal Braid ASTM B355 Class 4 OFHC
Nickel Plated Copper
for EMI Shielding Applications



Product Series
100-003

Dash Number
A 203 L

Lanyard
(Omit for None)

A = 36 AWG (Table I)
 B = 34 AWG (Table II)

Specify number of feet on purchase order.

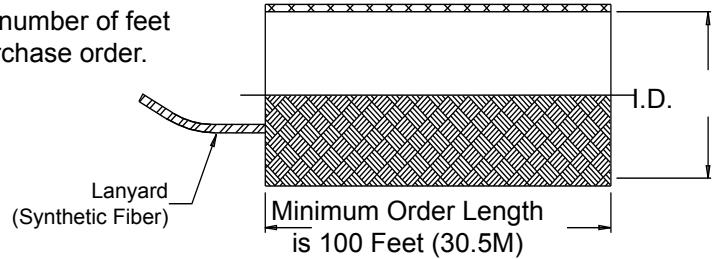

TABLE I: (36 AWG)

Dash No.	Fractional Equivalent	Nominal I.D.	No. of Carriers	No. of Ends	Current Rating Amps	Lbs./100 Ft. (Kg/30.5M)
031	1/32	.031 (0.8)	24	24	7.0	.20 (.09)
062	1/16	.062 (1.6)	24	48	11.0	.40 (.18)
078	5/64	.078 (2.0)	24	72	16.0	.60 (.27)
109	7/64	.109 (2.8)	24	96	19.0	.83 (.38)
125	1/8	.125 (3.2)	24	120	25.0	1.03 (.47)
156	5/32	.156 (4.0)	24	240	40.0	2.09 (.95)
171	11/64	.171 (4.3)	24	168	32.0	1.43 (.65)
188	3/16	.188 (4.8)	24	192	33.0	1.63 (.74)
203	13/64	.203 (5.2)	24	312	46.0	2.80 (1.27)
250	1/4	.250 (6.4)	24	384	53.0	3.45 (1.56)
375	3/8	.375 (9.5)	48	384	53.0	3.95 (1.79)
500	1/2	.500 (12.7)	48	528	62.0	4.77 (2.16)
562	9/16	.562 (14.3)	48	624	73.0	5.00 (2.27)
625	5/8	.625 (15.9)	48	720	85.0	5.94 (2.69)
781	25/32	.781 (19.8)	48	864	88.0	7.35 (3.33)
937	15/16	.937 (23.8)	64	640	65.0	5.83 (2.64)
1000	1	1.000 (25.4)	64	768	90.0	7.50 (3.40)
1250	1 1/4	1.250 (31.8)	72	792		
1375	1 3/8	1.375 (34.9)	72	864		
1500	1 1/2	1.500 (38.1)	72	936		
2000	2	2.000 (50.8)	96	1152		
2500	2 1/2	2.500 (63.5)	96	1248		

TABLE II: (34 AWG)

Dash No.	Fractional Equivalent	Nominal I.D.	No. of Carriers	No. of Ends	Current Rating Amps	Lbs./100 Ft. (Kg/30.5M)
062	1/16	.062 (1.6)	16	32	11.0	.43 (.20)
109	7/64	.109 (2.8)	16	64	19.0	.82 (.37)
125	1/8	.125 (3.2)	24	72	19.0	.92 (.42)
171	11/64	.171 (4.3)	24	120	36.0	1.56 (.71)
203	13/64	.203 (5.2)	24	192	46.0	2.79 (1.27)
375	3/8	.375 (9.5)	48	240	53.0	3.27 (1.48)
437	7/16	.437 (11.1)	48	288	44.2	3.93 (1.78)
500	1/2	.500 (12.7)	48	336	62.0	4.77 (2.16)
781	25/32	.781 (19.8)	48	528	88.0	7.14 (3.24)
1000	1	1.000 (25.4)	64	576	150.0	7.33 (3.33)
1250	1 1/4	1.250 (31.8)	72	648		

APPLICATION NOTES

- Direct current ratings are given for information only. Values shown are for uninsulated braid in free air at 86°F (30°C). Actual values will depend on permissible temperature rise, voltage drop and other conditions of service. Values should be de-rated if the braid is insulated or in close contact with other components.
- Consult factory for sizes not shown
- Metric dimensions (mm) are indicated in parentheses.





249-002
Conductive Gasket
to Fit MIL-DTL-38999 Series III
Flange Mount Receptacle Connector

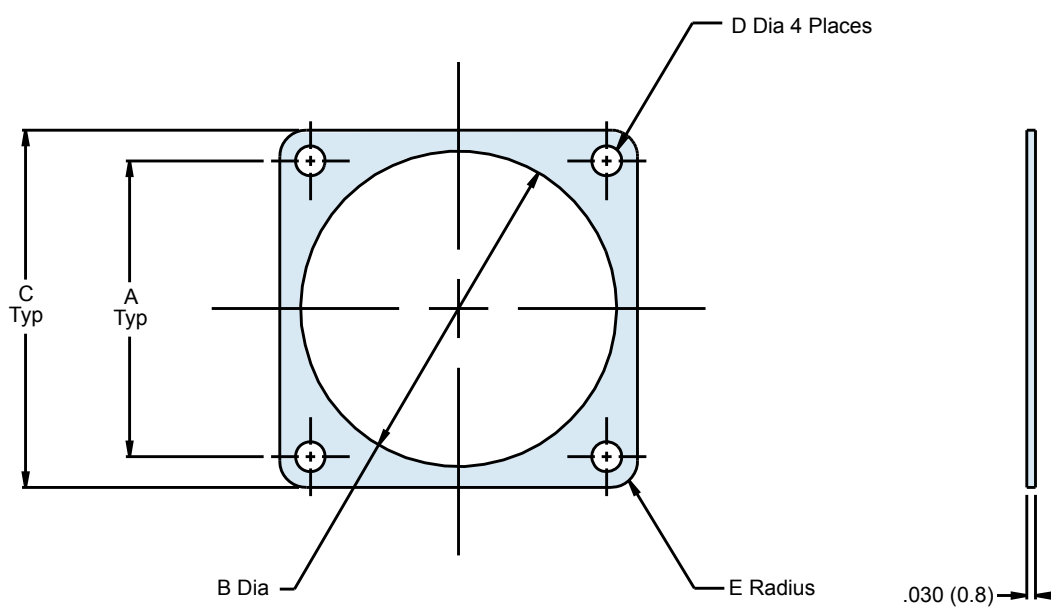
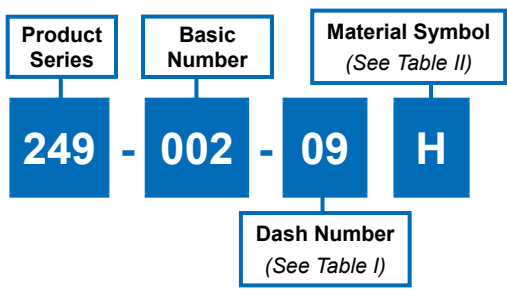

H

- NOTES:**
1. Identified by bag and tag in suitable quantities.
 2. Metric dimensions (mm) are indicated in parentheses.

249-002
Conductive Gasket
to Fit MIL-DTL-38999 Series III
Flange Mount Receptacle Connector



TABLE I

Dash Number	A ± .005	Ø B ± .007	C ± .008	Ø D ± .005	E Radius ± .015
-09	.719	.687	.937	.125	.105
-11	.812	.772	1.031	.125	.105
-13	.906	.937	1.125	.125	.105
-15	.969	1.063	1.250	.125	.135
-17	1.062	1.187	1.343	.125	.135
-19	1.156	1.312	1.467	.125	.135
-21	1.250	1.437	1.652	.125	.135
-23	1.375	1.562	1.703	.152	.135
-25	1.500	1.600	1.812	.152	.135

TABLE II

Designator	Material
C	Flourosilicone Binder with Passivated Silver Plated Aluminum Particles (CHO-Seal in 1298 or Equivalent)
H	Silicone Binder with Silver Plated Copper Particles (CHO-Seal 1215 or Equivalent)



MS85049/94 Full Perimeter Nut Plate for Flange Mount Receptacle Connector

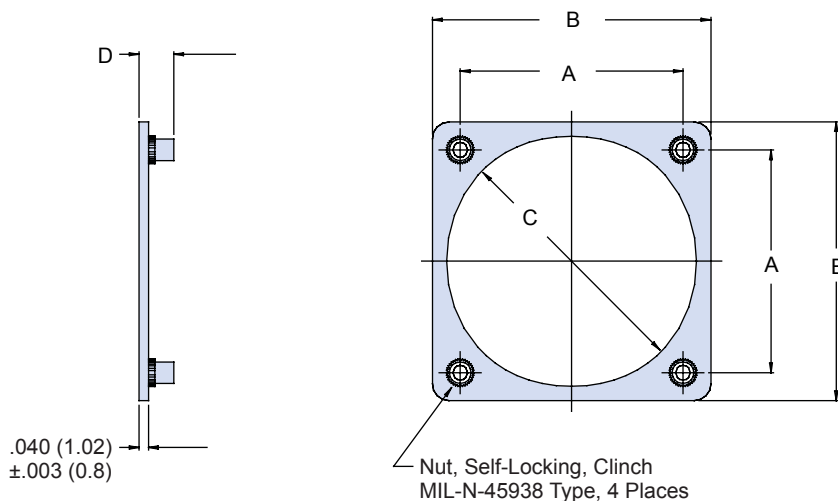
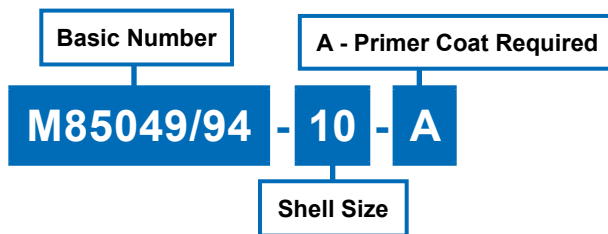

TABLE I

Shell Size	Thread UNJC-3B	A		B		C		D	
		± .015 (0.38)	()	Max.	()	± .015 (.4)	()	()	()
8	4-40	.594	(15.1)	.900	(22.9)	.570	(14.5)	.106	(.166)
10	4-40	.719	(18.3)	1.034	(26.3)	.720	(18.3)	.106	(.166)
12	4-40	.812	(20.6)	1.119	(28.4)	.835	(21.21)	.106	(.166)
14	4-40	.906	(23.0)	1.213	(30.8)	.950	(24.13)	.106	(.166)
16	4-40	.969	(24.6)	1.295	(32.9)	1.085	(27.56)	.106	(.166)
18	4-40	1.062	(27.0)	1.421	(36.1)	1.210	(30.73)	.106	(.166)
20	4-40	1.156	(29.4)	1.550	(39.4)	1.335	(33.91)	.106	(.166)
22	4-40	1.250	(31.8)	1.680	(42.7)	1.470	(37.34)	.106	(.166)
24	6-32	1.375	(34.9)	1.800	(45.7)	1.585	(40.26)	.123	(.183)
25	6-32	1.500	(38.1)	1.910	(48.5)	1.658	(42.11)	.123	(.183)



MS85049/95
3/4 Perimeter Nut Plate for
Flange Mount Receptacle Connector

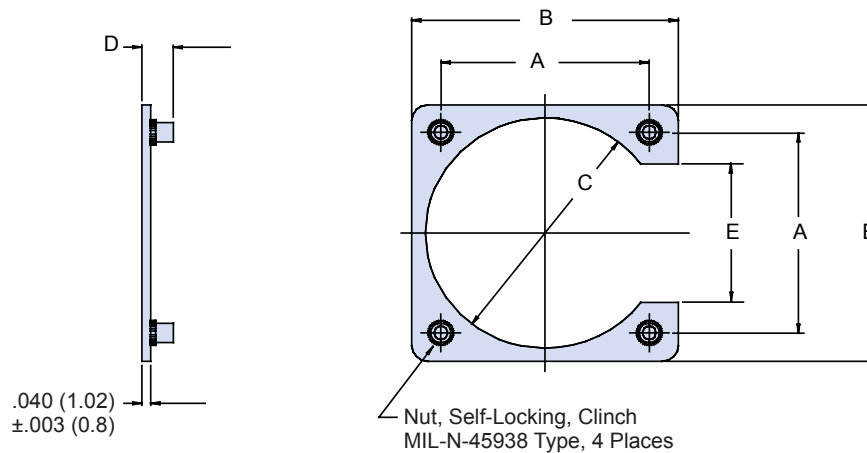
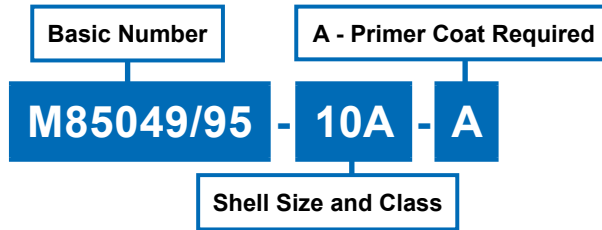

TABLE I

Shell Size	Thread UNJC-3B	A ± .003 (0.1)		B Max		C ± .015		D ± .030 (0.8)		E + .000 (.0) - .030 (.8)	
3A	4-40	.625	(15.9)	.940	(23.9)	.641	(16.3)	.136	(3.5)	.325	(8.3)
7A	4-40	.719	(18.3)	1.034	(26.3)	.688	(17.5)	.136	(3.5)	.433	(11.0)
8A	4-40	.594	(15.1)	.900	(22.9)	.570	(14.5)	.136	(3.5)	.308	(7.8)
10A	4-40	.719	(18.3)	1.034	(26.3)	.720	(18.3)	.136	(3.5)	.433	(11.0)
10B	6-32	.812	(20.6)	1.202	(30.5)	.749	(19.0)	.136	(3.5)	.433	(11.0)
12A	4-40	.812	(20.6)	1.119	(28.4)	.855	(21.7)	.136	(3.5)	.530	(13.5)
12B	6-32	.938	(23.8)	1.327	(33.7)	.938	(23.8)	.153	(3.9)	.526	(13.4)
14A	4-40	.906	(23.0)	1.213	(30.8)	.984	(25.0)	.136	(3.5)	.624	(15.8)
14B	6-32	1.031	(26.2)	1.421	(30.1)	1.031	(26.2)	.153	(3.9)	.620	(15.7)
16A	4-40	.969	(24.6)	1.295	(32.9)	1.094	(27.8)	.136	(3.5)	.687	(17.4)
16B	6-32	1.125	(28.6)	1.515	(38.5)	1.125	(28.6)	.153	(3.9)	.683	(17.3)
18A	4-40	1.062	(27.0)	1.421	(36.1)	1.220	(31.0)	.136	(3.5)	.780	(19.8)
18B	6-32	1.203	(30.6)	1.593	(40.5)	1.234	(31.3)	.153	(3.9)	.776	(19.7)
19A	4-40	.906	(23.0)	1.207	(30.7)	.953	(24.2)	.136	(3.5)	.620	(15.7)
20A	4-40	1.156	(29.4)	1.550	(39.4)	1.345	(34.2)	.136	(3.5)	.874	(22.2)
20B	6-32	1.297	(32.9)	1.703	(43.3)	1.359	(34.5)	.153	(3.9)	.865	(22.0)
22A	4-40	1.250	(31.8)	1.680	(42.7)	1.478	(37.5)	.136	(3.5)	.968	(24.6)
22B	6-32	1.375	(34.9)	1.753	(44.5)	1.483	(37.7)	.153	(3.9)	.907	(23.0)
24A	4-40	1.500	(38.1)	1.906	(48.4)	1.560	(39.6)	.153	(3.9)	1.000	(25.4)
24B	6-32	1.375	(34.9)	1.800	(45.7)	1.595	(40.5)	.153	(3.9)	1.031	(26.2)
25A	6-32	1.500	(38.1)	1.906	(48.4)	1.658	(42.1)	.153	(3.9)	1.125	(28.6)
27A	4-40	.969	(24.6)	1.270	(32.3)	1.094	(27.8)	.136	(3.5)	.683	(17.3)
28A	6-32	1.562	(39.7)	2.015	(51.2)	1.820	(46.2)	.153	(3.9)	1.125	(28.6)
32A	6-32	1.750	(44.5)	2.327	(59.1)	2.062	(52.4)	.153	(3.9)	1.188	(30.2)
36A	6-32	1.938	(49.2)	2.515	(63.9)	2.312	(58.7)	.153	(3.9)	1.375	(34.9)
37A	4-40	1.187	(30.1)	1.515	(38.5)	1.281	(32.5)	.136	(3.5)	.874	(22.2)
61A	4-40	1.437	(36.5)	1.827	(46.4)	1.594	(40.5)	.136	(3.5)	1.602	(40.7)



MS85049/96 1/4 Perimeter Nut Plate for Flange Mount Receptacle Connector

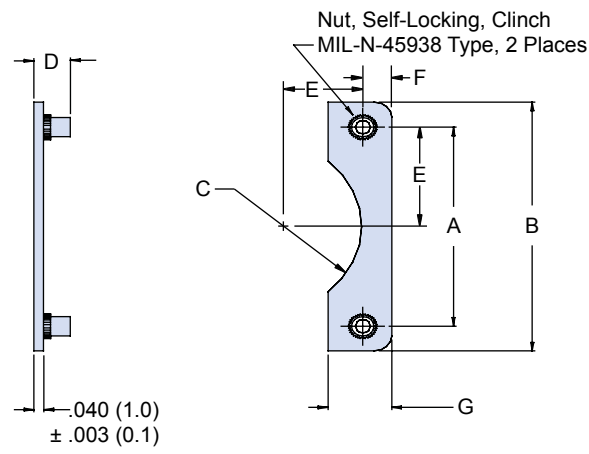
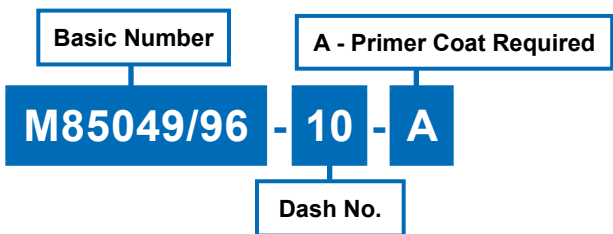

TABLE I								
Dash No.	Thread UNJC-3B	A ± .003 (0.1)	B Max	C (Min)	D ± .030 (0.8)	E ± .005 (0.1)	F (Ref)	G Max
3	4-40	.625 (15.9)	.940 (23.9)	.320 (8.1)	.136 (3.5)	.312 (7.92)	.150 (3.81)	.310 (7.87)
7	4-40	.719 (18.3)	1.034 (26.3)	.329 (8.4)	.136 (3.5)	.359 (9.12)	.149 (3.78)	.308 (7.82)
8	4-40	.594 (15.1)	.906 (23.0)	.262 (6.7)	.136 (3.5)	.297 (7.54)	.148 (3.76)	.306 (7.77)
10	4-40	.719 (18.3)	1.034 (26.3)	.344 (8.7)	.136 (3.5)	.359 (9.12)	.149 (3.78)	.308 (7.82)
12	4-40	.812 (20.6)	1.124 (28.6)	.410 (10.4)	.136 (3.5)	.406 (10.31)	.148 (3.76)	.306 (7.77)
14	4-40	.906 (23.0)	1.218 (30.9)	.492 (12.5)	.136 (3.5)	.453 (11.51)	.148 (3.76)	.306 (7.77)
16	4-40	.969 (24.6)	1.295 (32.9)	.532 (13.5)	.136 (3.5)	.484 (12.29)	.149 (3.78)	.308 (7.82)
18	4-40	1.062 (27.0)	1.405 (35.7)	.610 (15.5)	.136 (3.5)	.531 (13.49)	.164 (4.17)	.338 (8.59)
19	4-40	.906 (23.0)	1.218 (30.9)	.461 (11.7)	.136 (3.5)	.453 (11.51)	.148 (3.76)	.306 (7.77)
20	4-40	1.156 (29.4)	1.550 (39.4)	.657 (16.7)	.136 (3.5)	.578 (14.68)	.177 (4.50)	.364 (9.25)
22	4-40	1.250 (31.8)	1.680 (42.7)	.724 (18.4)	.136 (3.5)	.625 (15.88)	.195 (4.95)	.400 (10.16)
24	6-32	1.375 (34.9)	1.800 (45.7)	.782 (19.9)	.153 (3.9)	.687 (17.45)	.193 (4.90)	.396 (10.06)
25	6-32	1.500 (38.1)	1.906 (48.4)	.814 (20.7)	.153 (3.9)	.750 (19.05)	.179 (4.55)	.368 (9.35)
27	4-40	.969 (24.6)	1.281 (32.5)	.547 (13.9)	.136 (3.5)	.484 (12.29)	.149 (3.78)	.308 (7.82)
28	6-32	1.562 (39.7)	2.015 (51.2)	.895 (22.7)	.153 (3.9)	.781 (19.84)	.219 (5.56)	.448 (11.38)
32	6-32	1.750 (44.5)	2.327 (59.1)	1.016 (25.8)	.153 (3.9)	.875 (22.23)	.281 (7.14)	.572 (14.53)
36	6-32	1.938 (49.2)	2.515 (63.9)	1.141 (29.0)	.153 (3.9)	.969 (24.61)	.281 (7.14)	.572 (14.53)
37	4-40	1.187 (30.1)	1.515 (38.5)	.625 (15.9)	.136 (3.5)	.593 (15.06)	.157 (3.99)	.324 (8.23)
61	4-40	1.437 (36.5)	1.827 (46.4)	.732 (18.6)	.136 (3.5)	.718 (18.24)	.188 (4.78)	.386 (9.80)



What's Less than Half the Size and Weight of a D38999 Connector?



The Glenair Series 80 “Mighty Mouse”

Nothing tells the “Mighty Mouse” story better than the above picture. If your goal is to maintain the performance standards of the D38999 but to reduce the size and weight of the overall interconnect system, than the Series 80 “Mighty Mouse” is the answer. The “Mighty Mouse” offers up to 71% weight savings when compared to aluminum versions of the D38999 Series III.

Compared to composite D38999's the savings top out at 64%. Size reduction is equally dramatic. And the Series 80 “Mighty Mouse” accommodates the same range of wire sizes as the D38999 and matches the product on critical performance requirements such as vibration and shock. Best of all, the product is in stock and ready for immediate shipment.



1211 Air Way
Glendale, California 91201-2497
Telephone: 818-247-6000 · Facsimilie: 818-500-9912 · EMail: sales@glenair.com

United States · United Kingdom · Germany · Nordic · France · Italy · Spain

www.glenair.com



650FS001 Dummy Storage Receptacle for MIL-DTL-38999 Series I Connector

Basic Number	Shell Size
650FS001	M 17
Finish (Table II)	

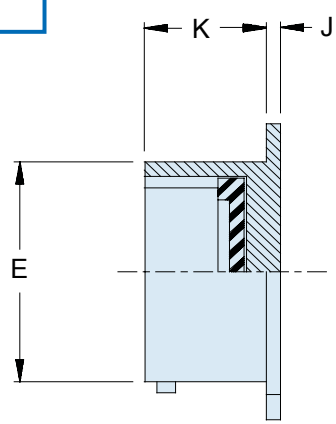
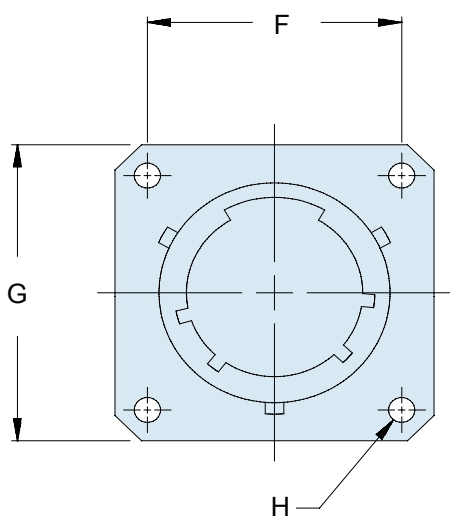

- APPLICATION NOTES**
1. See applicable Military Specification for complete dimensions.
 2. Metric dimensions (mm) are indicated in parentheses.

TABLE II: FINISHES	
Symbol	Finish
B	Cadmium Plate, Olive Drab
C	Anodize, Black
GB	Black Anodize, Hard Coat
M	Electroless Nickel
N	Cad Plate, Olive Drab over Electroless Nickel
NF	Cadmium Plate, Olive Drab over Electroless Nickel
MT	Ni-PTFE 1000 Hour Grey™ Nickel Fluorocarbon Polymer
ZN	Zinc-Nickel

TABLE I: DIMENSIONS						
Shell Size	E Max	F Dim	G Max	H Nom	J Max	K ±.010 (0.3)
9	572 (14.5)	.719 (18.3)	.958 (24.3)	.128 (3.3)	.085 (2.2)	.727 (18.5)
11	.701 (17.8)	.812 (20.6)	1.051 (26.7)	.128 (3.3)	.085 (2.2)	.727 (18.5)
13	.851 (21.6)	.906 (23.0)	1.145 (29.1)	.128 (3.3)	.085 (2.2)	.727 (18.5)
15	.976 (24.8)	.969 (24.6)	1.239 (31.5)	.128 (3.3)	.085 (2.2)	.727 (18.5)
17	1.101 (28.0)	1.062 (27.0)	1.332 (33.8)	.128 (3.3)	.085 (2.2)	.727 (18.5)
19	1.208 (30.7)	1.156 (29.4)	1.458 (37.0)	.128 (3.3)	.085 (2.2)	.727 (18.5)
21	1.333 (33.9)	1.250 (31.8)	1.582 (40.2)	.128 (3.3)	.115 (2.9)	.697 (17.7)
23	1.458 (37.0)	1.375 (34.9)	1.708 (43.4)	.147 (3.7)	.115 (2.9)	.697 (17.7)
25	1.583 (40.2)	1.500 (38.1)	1.832 (46.5)	.147 (3.7)	.115 (2.9)	.697 (17.7)

H

650FS002
Dummy Storage Receptacle for
MIL-DTL-38999 Series II Connector

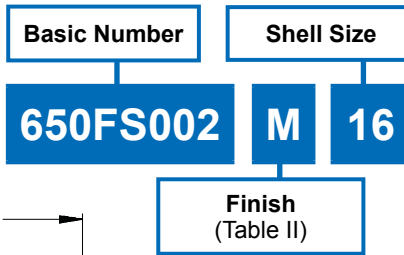
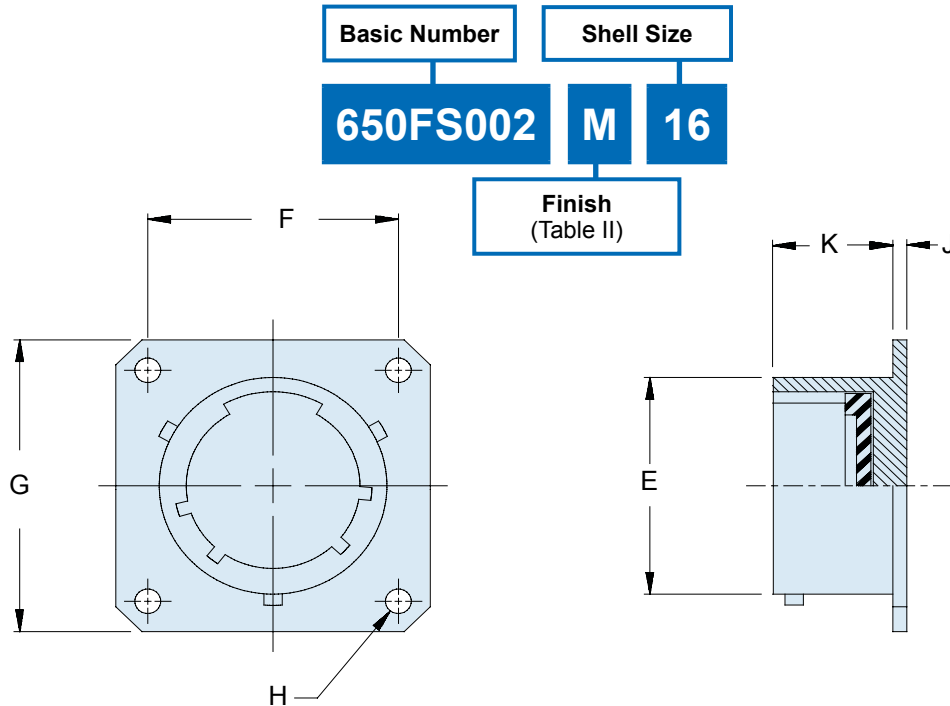

- APPLICATION NOTES**
1. See applicable Military Specification for complete dimensions.
 2. Metric dimensions (mm) are indicated in parentheses.

TABLE II: FINISHES

Symbol	Finish
B	Cadmium Plate, Olive Drab
C	Anodize, Black
GB	Black Anodize, Hard Coat
M	Electroless Nickel
N	Cad Plate, Olive Drab over Electroless Nickel
NF	Cadmium Plate, Olive Drab over Electroless Nickel
MT	Ni-PTFE 1000 Hour Grey™ Nickel Fluorocarbon Polymer
ZN	Zinc-Nickel

TABLE I: DIMENSIONS

Shell Size	E Max	F Dim	G Max	H Nom	J Max	K ±.010 (0.3)
8	.474 (12.0)	.594 (15.1)	.828 (21.0)	.120 (3.0)	.069 (1.8)	.451 (11.5)
10	.591 (15.0)	.719 (18.3)	.954 (24.2)	.120 (3.0)	.069 (1.8)	.451 (11.5)
12	.751 (19.1)	.812 (20.6)	1.047 (26.6)	.120 (3.0)	.069 (1.8)	.451 (11.5)
14	.876 (22.3)	.906 (23.0)	1.141 (29.0)	.120 (3.0)	.069 (1.8)	.451 (11.5)
16	1.001 (25.4)	.969 (24.6)	1.234 (31.3)	.120 (3.0)	.069 (1.8)	.451 (11.5)
18	1.126 (28.6)	1.062 (27.0)	1.328 (33.7)	.120 (3.0)	.069 (1.8)	.451 (11.5)
20	1.251 (31.8)	1.156 (29.4)	1.453 (36.9)	.120 (3.0)	.069 (1.8)	.451 (11.5)
22	1.376 (35.0)	1.250 (31.8)	1.578 (40.1)	.120 (3.0)	.069 (1.8)	.451 (11.5)
24	1.501 (38.1)	1.375 (34.9)	1.703 (43.3)	.147 (3.7)	.069 (1.8)	.451 (11.5)



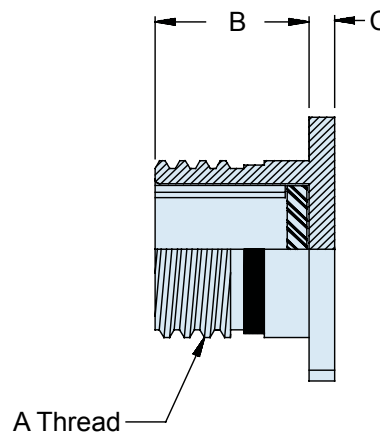
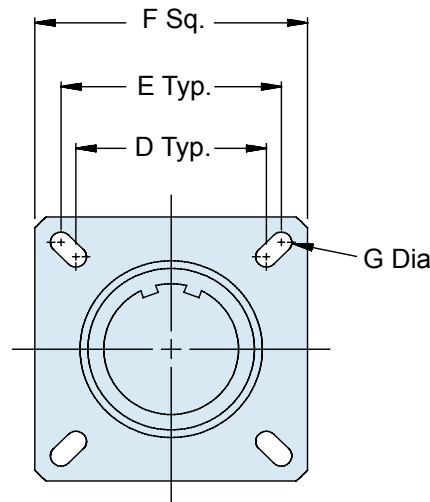
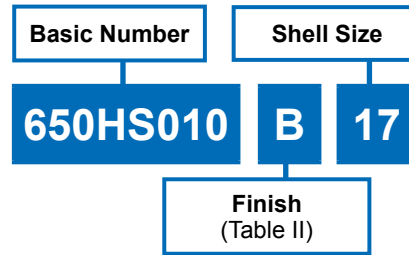

TABLE I: DIMENSIONS

Shell Size	Shell Size Ref	A Thread	B -0.0 +0.020 (0.5)	C ±0.012 (0.3)	D
A	9	.625-.1P-3LTS	.823 (20.9)	.098 (2.5)	.594 (15.09)
B	11	.750-.1P-3LTS	.823 (20.9)	.098 (2.5)	.719 (18.26)
C	13	.875-.1P-3LTS	.823 (20.9)	.098 (2.5)	.812 (20.62)
D	15	1.000-.1P-3LTS	.823 (20.9)	.098 (2.5)	.906 (23.01)
E	17	1.187-.1P-3LTS	.823 (20.9)	.098 (2.5)	.969 (24.61)
F	19	1.250-.1P-3LTS	.823 (20.9)	.098 (2.5)	1.062 (26.97)
G	21	1.375-.1P-3LTS	.791 (20.1)	.126 (3.2)	1.156 (29.36)
H	23	1.500-.1P-3LTS	.791 (20.1)	.126 (3.2)	1.250 (31.75)
J	25	1.625-.1P-3LTS	.791 (20.1)	.126 (3.2)	1.375 (34.93)

TABLE II: FINISHES

Symbol	Finish
B	Cadmium Plate, Olive Drab
C	Anodize, Black
GB	Black Anodize, Hard Coat
M	Electroless Nickel
N	Cad Plate, Olive Drab over Electroless Nickel
NF	Cadmium Plate, Olive Drab over Electroless Nickel
MT	Ni-PTFE 1000 Hour Grey™ Nickel Fluorocarbon Polymer
ZN	Zinc-Nickel

TABLE II: DIMENSIONS

Shell Size	Shell Size Ref	E	F ±0.012 (0.3)	G Dia ±0.008 (0.2)
A	9	.719 (18.26)	.937 (23.8)	.128 (3.25)
B	11	.812 (20.62)	1.031 (26.2)	.128 (3.25)
C	13	.906 (23.01)	1.126 (28.6)	.128 (3.25)
D	15	.969 (24.61)	1.220 (31.0)	.128 (3.25)
E	17	1.062 (26.97)	1.311 (33.3)	.128 (3.25)
F	19	1.156 (29.36)	1.437 (36.5)	.128 (3.25)
G	21	1.250 (31.75)	1.563 (39.7)	.128 (3.25)
H	23	1.375 (34.93)	1.689 (42.9)	.154 (3.91)
J	25	1.500 (38.10)	1.811 (46.0)	.154 (3.91)

APPLICATION NOTES

1. See applicable Military Specification for complete dimensions.
2. Metric dimensions (mm) are indicated in parentheses.

650HS007 Dummy Storage Receptacle for MIL-DTL-38999 Series IV Connector

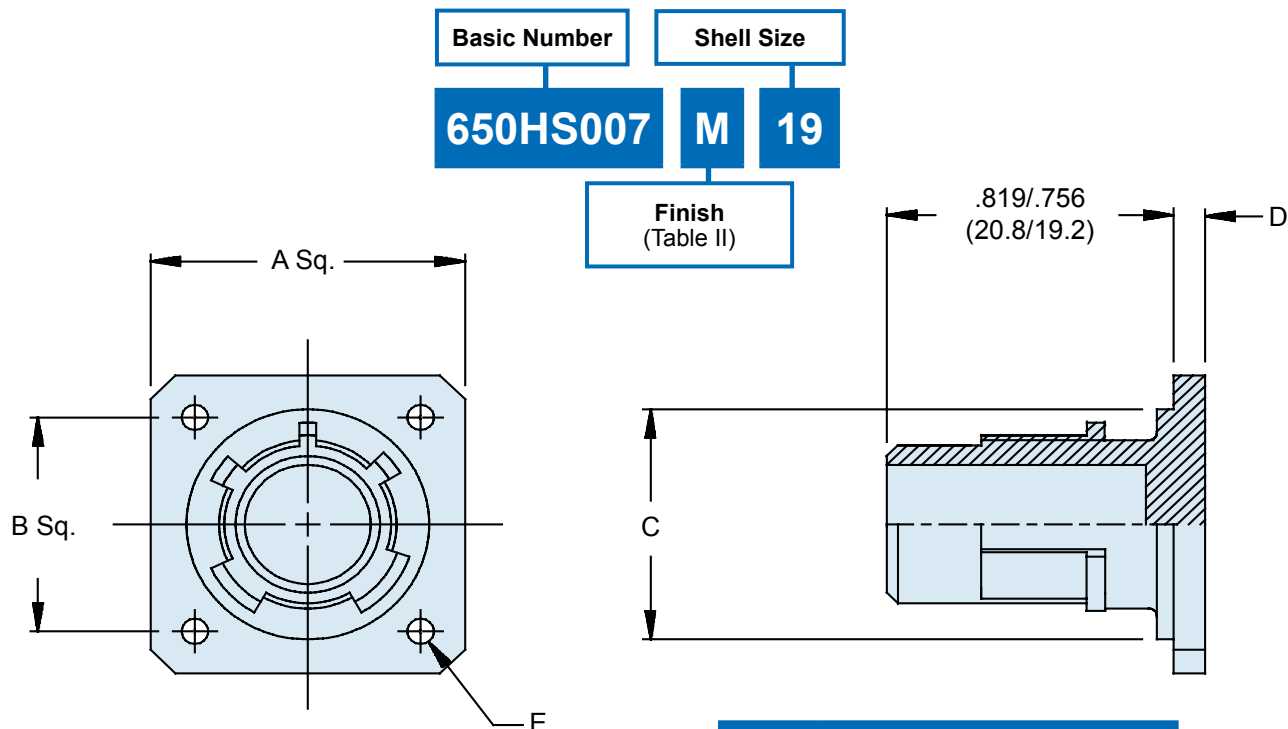

APPLICATION NOTES

1. See applicable Military Specification for complete dimensions.
2. Metric dimensions (mm) are indicated in parentheses.

Symbol	Finish
B	Cadmium Plate, Olive Drab
C	Anodize, Black
GB	Black Anodize, Hard Coat
M	Electroless Nickel
N	Cad Plate, Olive Drab over Electroless Nickel
NF	Cadmium Plate, Olive Drab over Electroless Nickel
MT	Ni-PTFE 1000 Hour Grey™ Nickel Fluorocarbon Polymer
ZN	Zinc-Nickel

Shell Size	Shell Size Ref	A ±.043 (±1.10)	G BSC	C +0 (0.00) -.015 (-0.39)	J Max	E Dia ±.008 (± 0.2)
B	11	1.030 (26.15)	.812 (20.62)	.793 (20.15)	.093 (2.35)	.130 (3.3)
C	13	1.124 (28.55)	.906 (23.02)	.919 (23.35)	.093 (2.35)	.130 (3.3)
D	15	1.219 (30.95)	.969 (24.62)	1.044 (26.52)	.093 (2.35)	.130 (3.3)
E	17	1.313 (33.35)	1.062 (26.98)	1.170 (29.72)	.093 (2.35)	.130 (3.3)
F	19	1.439 (36.55)	1.156 (29.36)	1.294 (32.87)	.093 (2.35)	.130 (3.3)
G	21	1.561 (39.65)	1.250 (31.76)	1.419 (36.05)	.124 (3.15)	.130 (3.3)
H	23	1.687 (42.85)	1.375 (34.92)	1.544 (39.22)	.124 (3.15)	.142 (3.6)
J	25	1.813 (46.05)	1.500 (38.10)	1.669 (42.40)	.124 (3.15)	.142 (3.6)





**660-012 (Plug) - 660-013 (Receptacle)
661-002 (EMI Receptacle)
Protective Covers
MIL-C-38999 Series I**

**MIL-C-38999
Series I**

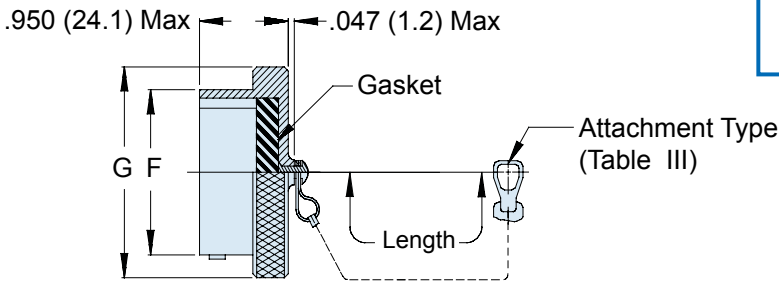
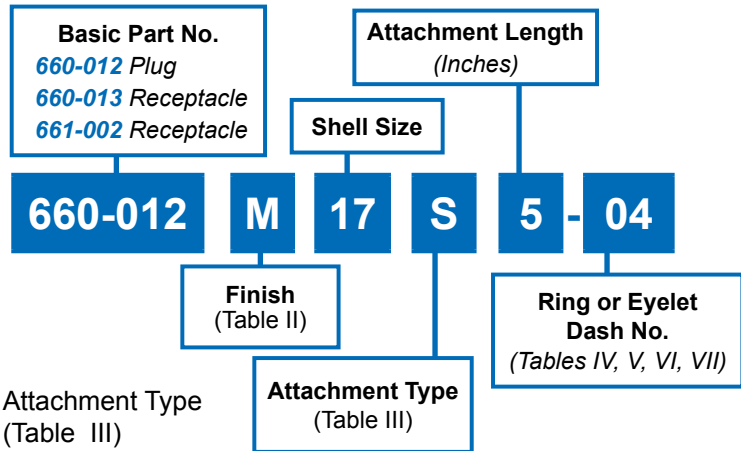

660-012 Plug Cover

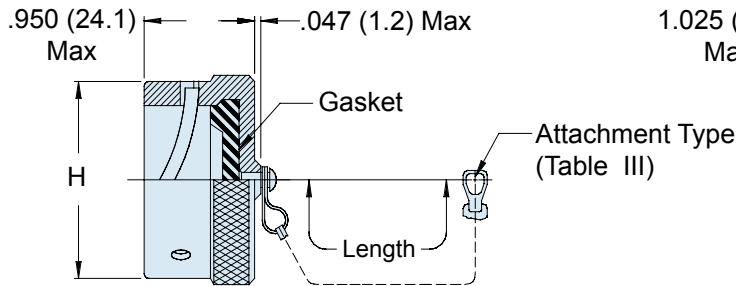

660-013 Receptacle Cover

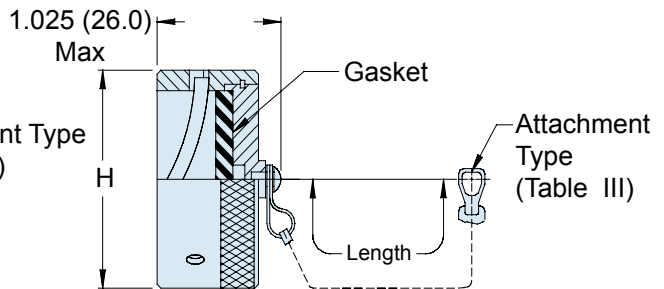

661-002 EMI/RFI Receptacle Cover

TABLE I: SHELL SIZE DIMENSIONS			
Shell Size	F Dia	G Dia Max	H Max
09	.572 (14.5)	.820 (20.8)	.844 (21.4)
11	.700 (17.8)	.940 (23.9)	.968 (24.6)
13	.850 (21.6)	1.070 (27.2)	1.125 (28.6)
15	.975 (24.8)	1.190 (30.2)	1.250 (31.8)
17	1.100 (27.9)	1.320 (33.5)	1.406 (35.7)
19	1.207 (30.7)	1.440 (36.6)	1.500 (38.1)
21	1.332 (33.8)	1.570 (39.9)	1.625 (41.3)
23	1.457 (37.0)	1.690 (42.9)	1.750 (44.5)
25	1.582 (40.2)	1.820 (46.2)	1.875 (47.6)

Metric dimensions (mm) are indicated in parentheses.

TABLE II: FINISHES	
Symbol	Finish
B	Cadmium Plate, Olive Drab
C	Anodize, Black
GB	Black Anodize, Hard Coat
M	Electroless Nickel
N	Cad Plate, Olive Drab over Electroless Nickel
NF	Cadmium Plate, Olive Drab over Electroless Nickel
MT	Ni-PTFE 1000 Hour Grey™ Nickel Fluorocarbon Polymer
Z1	Stainless Steel Passivate
ZN	Zinc-Nickel

**660-012 (Plug) - 660-013 (Receptacle)
661-002 (EMI Receptacle)
Protective Covers
MIL-C-38999 Series I**

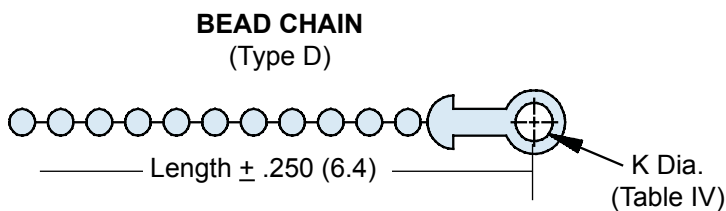
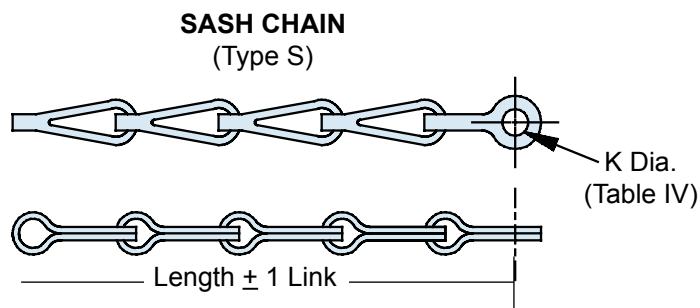
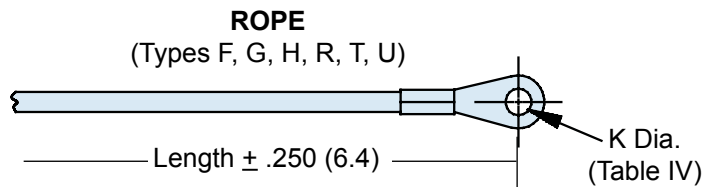

TABLE III: ATTACHMENTS

Sym	Attachment Type
D	Bead Chain, Cres, Passivate
F	Wire Rope, Nylon Jacket
G	Nylon Rope
H	Wire Rope, Teflon Jacket
N	No Attachment
R	Wire Rope, PVC Jacket
S	#8 Sash Chain, Cres, Passivate
T	Wire Rope, No Jacket
U	Wire Rope, Polyurethane Jacket with Terminal

TABLE IV: EYELET

Dash No.	K Dia ±.010 (0.3)
01	.140 (3.6)
02	.182 (4.6)
03	.191 (4.9)
04	.197 (5.0)
05	.167 (4.2)
06	.125 (3.2)
07	.218 (5.5)
09	.156 (4.0)
00	No Eyelet

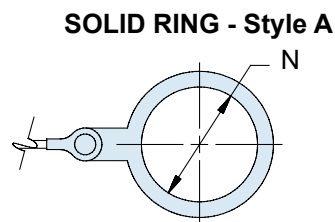
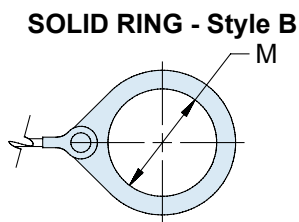
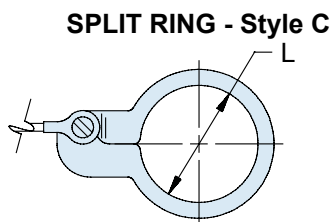

TABLE V: STYLE C RING DIA.

Dash No.	N Dia ±.015 (0.4)	Dash No.	N Dia ±.015 (0.4)
50	.425 (10.8)	74	1.625 (41.3)
52	.485 (12.3)	76	1.750 (44.5)
54	.640 (16.3)	78	1.875 (47.6)
56	.750 (19.1)	80	1.980 (50.3)
58	.890 (22.6)	82	2.060 (52.3)
60	1.015 (25.8)	84	2.235 (56.8)
62	1.095 (27.8)	86	2.310 (58.7)
64	1.130 (28.7)	88	2.475 (62.9)
66	1.250 (31.8)	90	2.655 (67.4)
68	1.350 (34.3)	92	2.810 (71.4)
70	1.390 (35.3)	94	3.045 (77.3)
72	1.485 (37.7)		

TABLE VI: STYLE B RING DIA.

Dash No.	N Dia ±.015 (0.4)	Dash No.	N Dia ±.015 (0.4)
08	.468 (11.9)	24	1.484 (37.7)
10	.593 (15.1)	25	1.577 (40.1)
12	.718 (18.2)	27	1.640 (41.7)
13	.765 (19.4)	28	1.687 (42.8)
14	.844 (21.4)	29	1.765 (44.8)
15	.890 (22.6)	30	1.890 (48.0)
16	.968 (24.6)	31	1.953 (49.6)
17	1.015 (25.8)	32	1.968 (50.0)
18	1.093 (27.8)	33	2.077 (52.8)
19	1.140 (29.0)	35	2.140 (54.4)
20	1.203 (30.6)	36	2.187 (55.5)
21	1.265 (32.1)	40	2.406 (61.1)
22	1.343 (34.1)	44	2.656 (67.5)
23	1.453 (36.9)	48	3.031 (77.0)
		118	.310 (7.9)

TABLE VII: STYLE A RING DIA.

Dash No.	N Dia ±.015 (0.4)	Dash No.	N Dia ±.015 (0.4)
095	.312 (7.9)	109	1.266 (32.2)
100	.391 (9.9)	209	1.312 (33.3)
101	101.516 (13.1)	110	1.391 (35.3)
102	102.583 (14.8)	210	1.438 (36.5)
103	103.641 (16.3)	111	1.521 (38.6)
104	104.708 (18.0)	211	1.536 (39.0)
105	105.766 (19.5)	112	1.641 (41.7)
205	205.788 (20.0)	113	1.766 (44.9)
106	106.896 (22.2)	213	1.812 (46.0)
206	206.907 (23.0)	114	1.891 (48.0)
107	1071.016 (25.8)	214	1.938 (49.2)
207	2071.025 (26.0)	115	2.078 (52.8)
108	1081.141 (29.0)	116	2.406 (61.1)
308	3081.188 (30.2)	117	2.510 (63.8)
208	2081.203 (30.6)		



**MIL-C-38999
Series II**

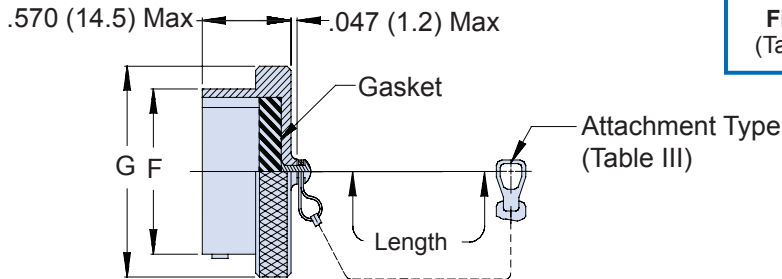
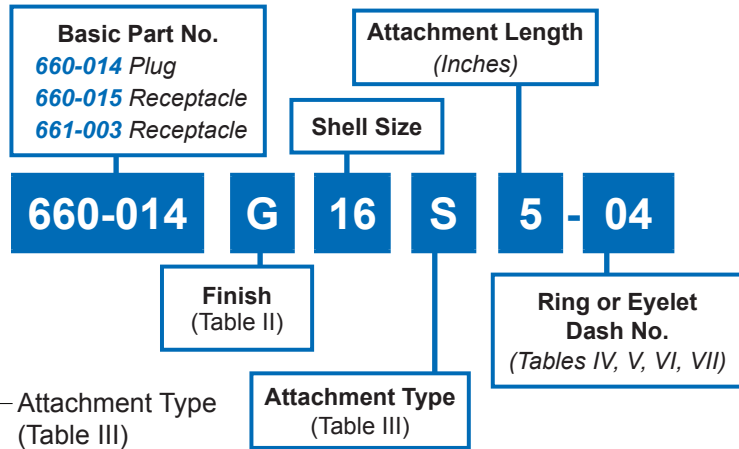

660-014 Plug Cover

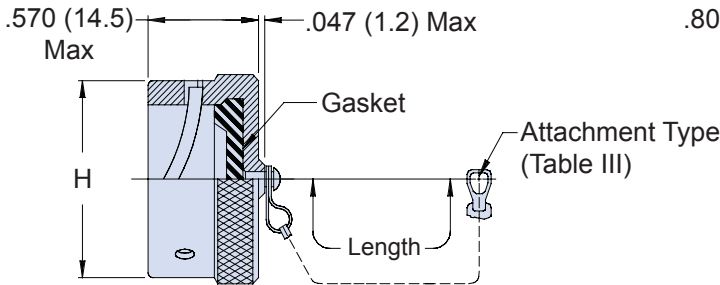

660-015 Receptacle Cover

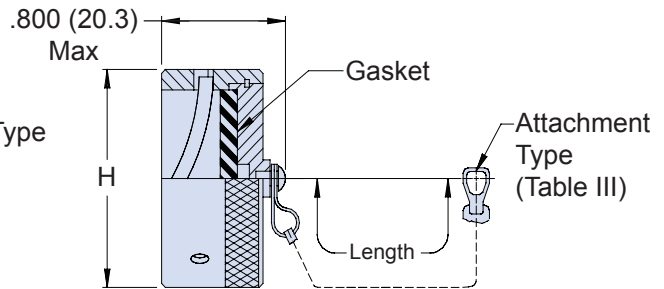

661-003 EMI/RFI Receptacle Cover

SHELL SIZE DIMENSIONS			
Shell Size	F Dia	G Dia Max	H Max
08	.473 (12.0)	.720 (18.3)	.719 (18.3)
10	.590 (15.0)	.850 (21.6)	.812 (20.6)
12	.750 (19.1)	1.000 (25.4)	1.000 (25.4)
14	.875 (22.2)	1.130 (28.7)	1.125 (28.6)
16	1.000 (25.4)	1.250 (31.8)	1.250 (31.8)
18	1.125 (28.6)	1.380 (35.1)	1.375 (34.9)
20	1.250 (31.8)	1.500 (38.1)	1.500 (38.1)
22	1.375 (34.9)	1.630 (41.4)	1.625 (41.3)
24	1.500 (38.1)	1.750 (44.5)	1.750 (44.5)

Metric dimensions (mm) are indicated in parentheses.

TABLE II: FINISHES	
Symbol	Finish
B	Cadmium Plate, Olive Drab
C	Anodize, Black
GB	Black Anodize, Hard Coat
M	Electroless Nickel
N	Cad Plate, Olive Drab over Electroless Nickel
NF	Cadmium Plate, Olive Drab over Electroless Nickel
MT	Ni-PTFE 1000 Hour Grey™ Nickel Fluorocarbon Polymer
Z1	Stainless Steel Passivate
ZN	Zinc-Nickel

H

**660-014 (Plug) - 660-015 (Receptacle)
661-003 (EMI Receptacle)
Protective Covers
MIL-C-38999 Series II**

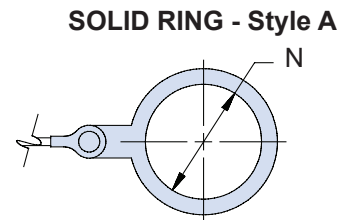
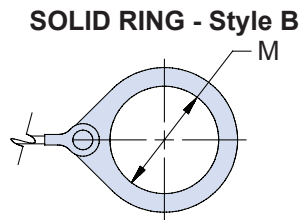
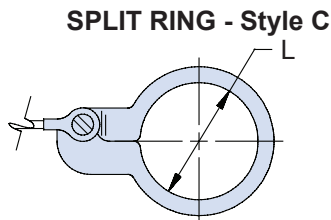
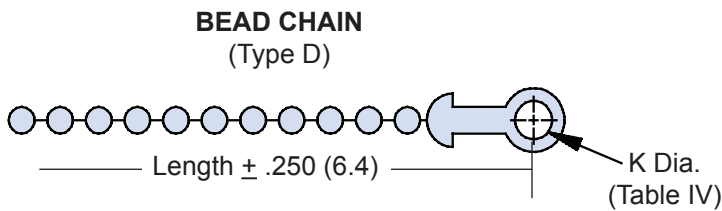
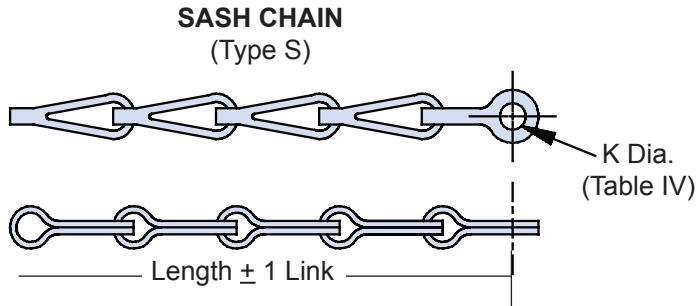
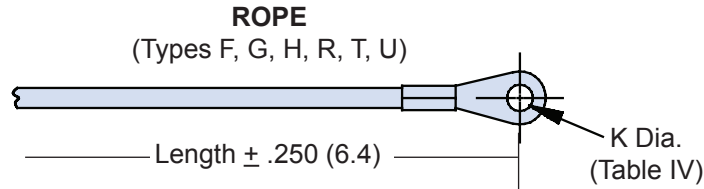

TABLE III: ATTACHMENTS

Sym	Attachment Type
D	Bead Chain, Cres, Passivate
F	Wire Rope, Nylon Jacket
G	Nylon Rope
H	Wire Rope, Teflon Jacket
N	No Attachment
R	Wire Rope, PVC Jacket
S	#8 Sash Chain, Cres, Passivate
T	Wire Rope, No Jacket
U	Wire Rope, Polyurethane Jacket with Terminal

TABLE IV: EYELET

Dash No.	K Dia ±.010 (0.3)
01	.140 (3.6)
02	.182 (4.6)
03	.191 (4.9)
04	.197 (5.0)
05	.167 (4.2)
06	.125 (3.2)
07	.218 (5.5)
09	.156 (4.0)
00	No Eyelet

TABLE V: STYLE C RING DIA.

Dash No.	N Dia ±.015 (0.4)	Dash No.	N Dia ±.015 (0.4)
50	.425 (10.8)	74	1.625 (41.3)
52	.485 (12.3)	76	1.750 (44.5)
54	.640 (16.3)	78	1.875 (47.6)
56	.750 (19.1)	80	1.980 (50.3)
58	.890 (22.6)	82	2.060 (52.3)
60	1.015 (25.8)	84	2.235 (56.8)
62	1.095 (27.8)	86	2.310 (58.7)
64	1.130 (28.7)	88	2.475 (62.9)
66	1.250 (31.8)	90	2.655 (67.4)
68	1.350 (34.3)	92	2.810 (71.4)
70	1.390 (35.3)	94	3.045 (77.3)
72	1.485 (37.7)		

TABLE VI: STYLE B RING DIA.

Dash No.	N Dia ±.015 (0.4)	Dash No.	N Dia ±.015 (0.4)
08	.468 (11.9)	24	1.484 (37.7)
10	.593 (15.1)	25	1.577 (40.1)
12	.718 (18.2)	27	1.640 (41.7)
13	.765 (19.4)	28	1.687 (42.8)
14	.844 (21.4)	29	1.765 (44.8)
15	.890 (22.6)	30	1.890 (48.0)
16	.968 (24.6)	31	1.953 (49.6)
17	1.015 (25.8)	32	1.968 (50.0)
18	1.093 (27.8)	33	2.077 (52.8)
19	1.140 (29.0)	35	2.140 (54.4)
20	1.203 (30.6)	36	2.187 (55.5)
21	1.265 (32.1)	40	2.406 (61.1)
22	1.343 (34.1)	44	2.656 (67.5)
23	1.453 (36.9)	48	3.031 (77.0)
		118	.310 (7.9)

TABLE VII: STYLE A RING DIA.

Dash No.	N Dia ±.015 (0.4)	Dash No.	N Dia ±.015 (0.4)
095	.312 (7.9)	109	1.266 (32.2)
100	.391 (9.9)	209	1.312 (33.3)
101	.516 (13.1)	110	1.391 (35.3)
102	.583 (14.8)	210	1.438 (36.5)
103	.641 (16.3)	111	1.521 (38.6)
104	.708 (18.0)	211	1.536 (39.0)
105	.766 (19.5)	112	1.641 (41.7)
205	.788 (20.0)	113	1.766 (44.9)
106	.896 (22.7)	213	1.812 (46.0)
206	.907 (23.0)	114	1.891 (48.0)
107	1.016 (25.8)	214	1.938 (49.2)
207	1.025 (26.0)	115	2.078 (52.8)
108	1.141 (29.0)	116	2.406 (61.1)
308	1.188 (30.2)	117	2.510 (63.8)
208	1.203 (30.6)		



660-023 (Plug) - 660-024 (Receptacle)
Protective Covers
MIL-C-38999 Series III Threaded

MIL-C-38999
Series III

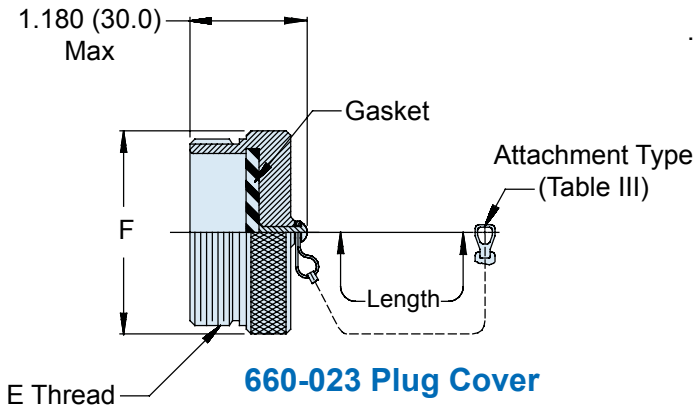
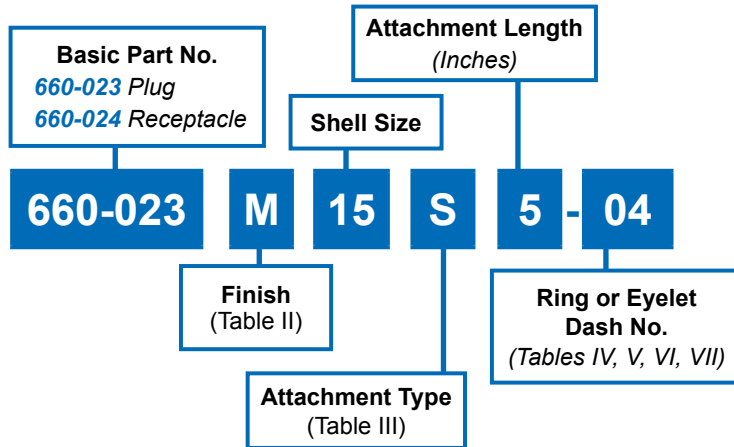

660-023 Plug Cover

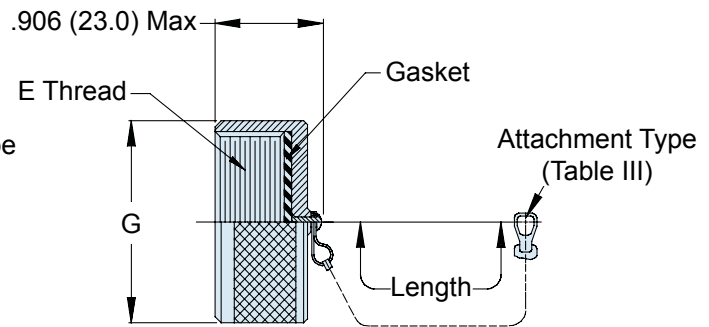

660-024 Receptacle Cover

SHELL SIZE DIMENSIONS

Shell Size	Shell Size Code Ref.	E Thread	F Max	G Max
09	A	.6250-0.1P-0.3L-TS	.906 (23.0)	.906 (23.0)
11	B	.7500-0.1P-0.3L-TS	1.024 (26.0)	1.102 (28.0)
13	C	.8750-0.1P-0.3L-TS	1.220 (31.0)	1.220 (31.0)
15	D	1.0000-0.1P-0.3L-TS	1.300 (33.0)	1.260 (32.0)
17	E	1.1875-0.1P-0.3L-TS	1.457 (37.0)	1.457 (37.0)
19	F	1.2500-0.1P-0.3L-TS	1.575 (40.0)	1.535 (39.0)
21	G	1.3750-0.1P-0.3L-TS	1.732 (44.0)	1.654 (42.0)
23	H	1.5000-0.1P-0.3L-TS	1.811 (46.0)	1.772 (45.0)
25	J	1.6250-0.1P-0.3L-TS	1.969 (50.0)	1.929 (49.0)

Metric dimensions (mm) are indicated in parentheses.

TABLE II: FINISHES

Symbol	Finish
B	Cadmium Plate, Olive Drab
C	Anodize, Black
GB	Black Anodize, Hard Coat
M	Electroless Nickel
N	Cad Plate, Olive Drab over Electroless Nickel
NF	Cadmium Plate, Olive Drab over Electroless Nickel
MT	Ni-PTFE 1000 Hour Grey™ Nickel Fluorocarbon Polymer
Z1	Stainless Steel Passivate
ZN	Zinc-Nickel

H

660-023 (Plug) - 660-024 (Receptacle)
Protective Covers
MIL-C-38999 Series III Threaded

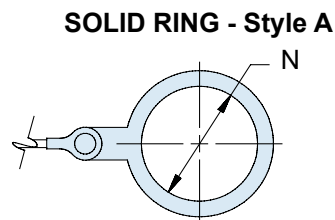
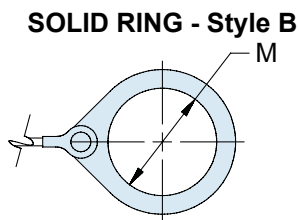
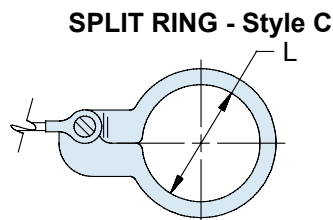
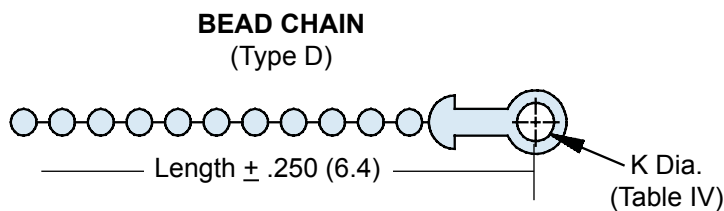
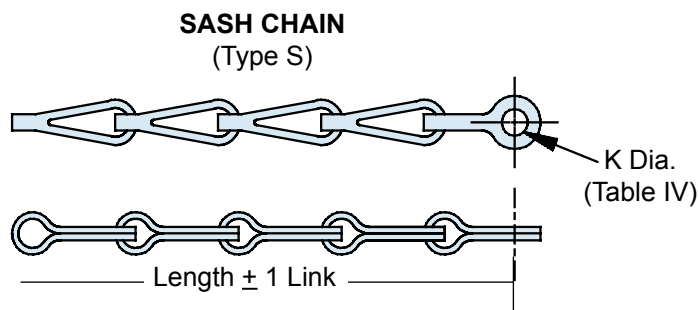
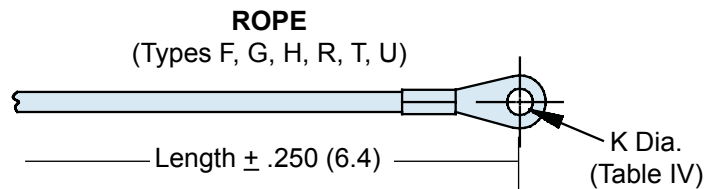

TABLE III: ATTACHMENTS

Sym	Attachment Type
D	Bead Chain, Cres, Passivate
F	Wire Rope, Nylon Jacket
G	Nylon Rope
H	Wire Rope, Teflon Jacket
N	No Attachment
R	Wire Rope, PVC Jacket
S	#8 Sash Chain, Cres, Passivate
T	Wire Rope, No Jacket
U	Wire Rope, Polyurethane Jacket with Terminal

TABLE IV: EYELET

Dash No.	K Dia ±.010 (0.3)
01	.140 (3.6)
02	.182 (4.6)
03	.191 (4.9)
04	.197 (5.0)
05	.167 (4.2)
06	.125 (3.2)
07	.218 (5.5)
09	.156 (4.0)
00	No Eyelet

TABLE V: STYLE C RING DIA.

Dash No.	N Dia ±.015 (0.4)	Dash No.	N Dia ±.015 (0.4)
50	.425 (10.8)	74	1.625 (41.3)
52	.485 (12.3)	76	1.750 (44.5)
54	.640 (16.3)	78	1.875 (47.6)
56	.750 (19.1)	80	1.980 (50.3)
58	.890 (22.6)	82	2.060 (52.3)
60	1.015 (25.8)	84	2.235 (56.8)
62	1.095 (27.8)	86	2.310 (58.7)
64	1.130 (28.7)	88	2.475 (62.9)
66	1.250 (31.8)	90	2.655 (67.4)
68	1.350 (34.3)	92	2.810 (71.4)
70	1.390 (35.3)	94	3.045 (77.3)
72	1.485 (37.7)		

TABLE VI: STYLE B RING DIA.

Dash No.	N Dia ±.015 (0.4)	Dash No.	N Dia ±.015 (0.4)
08	.468 (11.9)	24	1.484 (37.7)
10	.593 (15.1)	25	1.577 (40.1)
12	.718 (18.2)	27	1.640 (41.7)
13	.765 (19.4)	28	1.687 (42.8)
14	.844 (21.4)	29	1.765 (44.8)
15	.890 (22.6)	30	1.890 (48.0)
16	.968 (24.6)	31	1.953 (49.6)
17	1.015 (25.8)	32	1.968 (50.0)
18	1.093 (27.8)	33	2.077 (52.8)
19	1.140 (29.0)	35	2.140 (54.4)
20	1.203 (30.6)	36	2.187 (55.5)
21	1.265 (32.1)	40	2.406 (61.1)
22	1.343 (34.1)	44	2.656 (67.5)
23	1.453 (36.9)	48	3.031 (77.0)
		118	.310 (7.9)

TABLE VII: STYLE A RING DIA.

Dash No.	N Dia ±.015 (0.4)	Dash No.	N Dia ±.015 (0.4)
095	.312 (7.9)	109	1.266 (32.2)
100	.391 (9.9)	209	1.312 (33.3)
101	.516 (13.1)	110	1.391 (35.3)
102	.583 (14.8)	210	1.438 (36.5)
103	.641 (16.3)	111	1.521 (38.6)
104	.708 (18.0)	211	1.536 (39.0)
105	.766 (19.5)	112	1.641 (41.7)
205	.788 (20.0)	113	1.766 (44.9)
106	.896 (22.2)	213	1.812 (46.0)
206	.907 (23.0)	114	1.891 (48.0)
107	1.016 (25.8)	214	1.938 (49.2)
207	1.025 (26.0)	115	2.078 (52.8)
108	1.141 (29.0)	116	2.406 (61.1)
308	1.188 (30.2)	117	2.510 (63.8)
208	1.203 (30.6)		





660-031 (Receptacle) - 660-032 (Plug)
Protective Covers
MIL-C-38999 Series IV

MIL-C-38999
Series IV

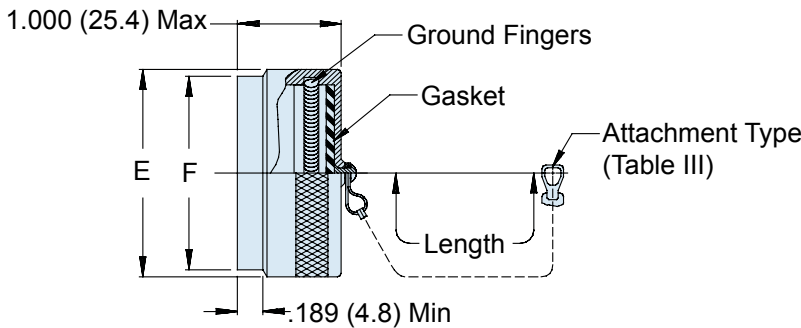
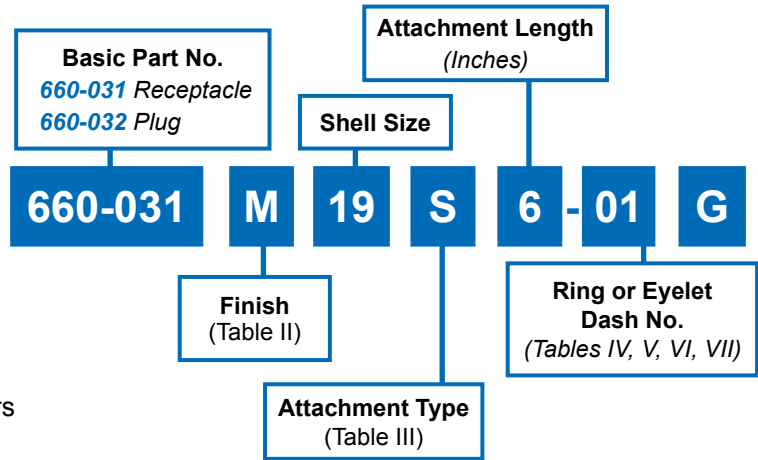

660-031 Receptacle Cover

TABLE II: FINISHES	
Symbol	Finish
MT	Ni-PTFE
M	Electroless Nickel
NF	Cadmium Plate, Olive Drab over Electroless Nickel

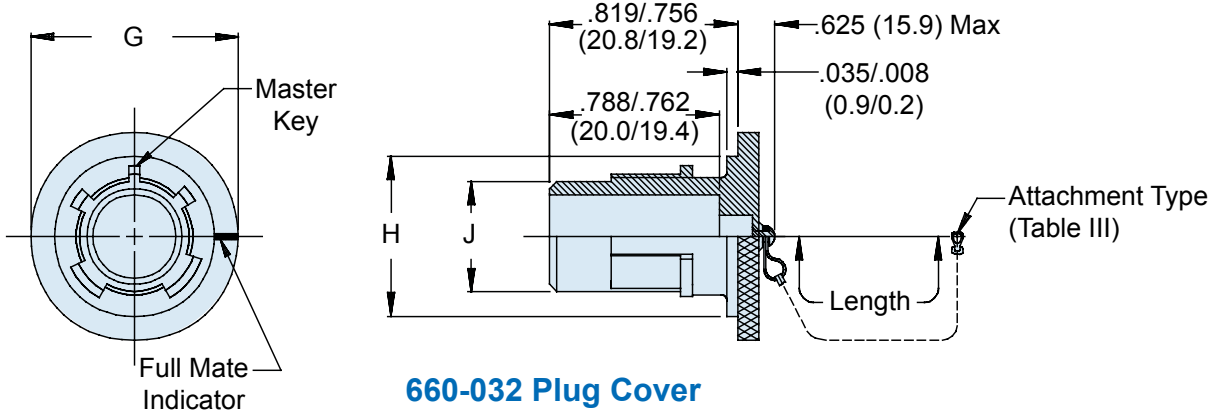

660-032 Plug Cover

SHELL SIZE DIMENSIONS						
Shell Size	Shell Size Code Ref.	E Dia Max	F Dia Max	G Dia Max	H Dia +0.0 (+0.0) -0.015 (-0.4)	J Dia +0.0 (+0.0) -0.015 (-0.4)
11	B	.875 (22.2)	.775 (19.7)	1.180 (30.0)	.793 (20.1)	.509 (12.9)
13	C	1.000 (25.4)	.901 (22.9)	1.320 (33.5)	.919 (23.3)	.634 (16.1)
15	D	1.125 (28.6)	1.039 (26.4)	1.440 (36.6)	1.044 (26.5)	.759 (19.3)
17	E	1.250 (31.8)	1.150 (29.2)	1.560 (39.6)	1.170 (29.7)	.885 (22.5)
19	F	1.375 (34.9)	1.276 (32.4)	1.680 (42.7)	1.294 (32.9)	1.009 (25.6)
21	G	1.500 (38.1)	1.402 (35.6)	1.820 (46.2)	1.419 (36.0)	1.134 (28.8)
23	H	1.625 (41.3)	1.528 (38.8)	1.940 (49.3)	1.544 (39.2)	1.259 (32.0)
25	J	1.750 (44.5)	1.650 (41.9)	2.060 (52.3)	1.669 (42.4)	1.384 (35.2)

Metric dimensions (mm) are indicated in parentheses.

**660-031 (Receptacle) - 660-032 (Plug)
Protective Covers
MIL-C-38999 Series IV**

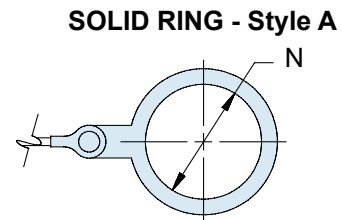
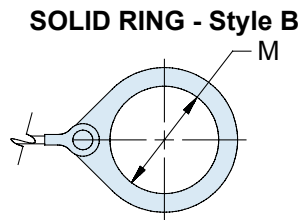
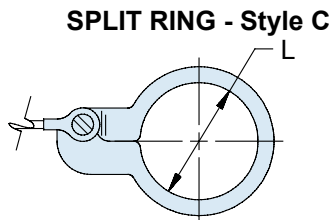
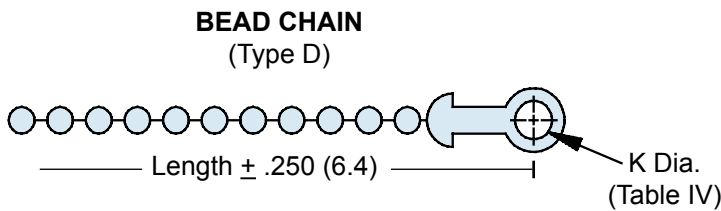
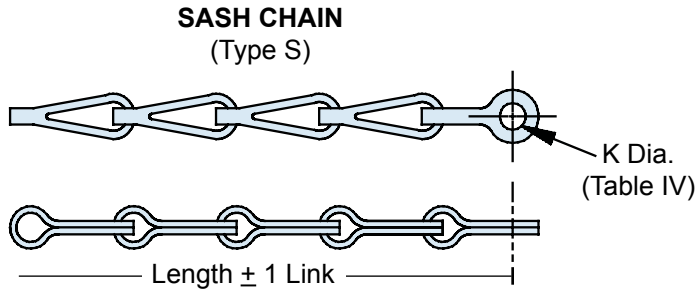
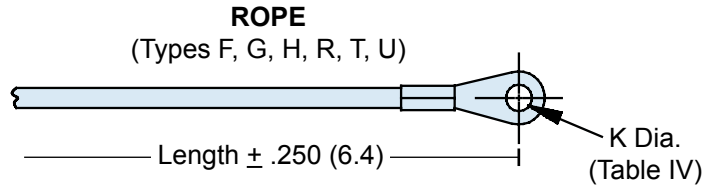

TABLE III: ATTACHMENTS

Sym	Attachment Type
D	Bead Chain, Cres, Passivate
F	Wire Rope, Nylon Jacket
G	Nylon Rope
H	Wire Rope, Teflon Jacket
N	No Attachment
R	Wire Rope, PVC Jacket
S	#8 Sash Chain, Cres, Passivate
T	Wire Rope, No Jacket
U	Wire Rope, Polyurethane Jacket with Terminal

TABLE IV: EYELET

Dash No.	K Dia ±.010 (0.3)
01	.140 (3.6)
02	.182 (4.6)
03	.191 (4.9)
04	.197 (5.0)
05	.167 (4.2)
06	.125 (3.2)
07	.218 (5.5)
09	.156 (4.0)
00	No Eyelet

TABLE V: STYLE C RING DIA.

Dash No.	N Dia ±.015 (0.4)	Dash No.	N Dia ±.015 (0.4)
50	.425 (10.8)	74	1.625 (41.3)
52	.485 (12.3)	76	1.750 (44.5)
54	.640 (16.3)	78	1.875 (47.6)
56	.750 (19.1)	80	1.980 (50.3)
58	.890 (22.6)	82	2.060 (52.3)
60	1.015 (25.8)	84	2.235 (56.8)
62	1.095 (27.8)	86	2.310 (58.7)
64	1.130 (28.7)	88	2.475 (62.9)
66	1.250 (31.8)	90	2.655 (67.4)
68	1.350 (34.3)	92	2.810 (71.4)
70	1.390 (35.3)	94	3.045 (77.3)
72	1.485 (37.7)		

TABLE VI: STYLE B RING DIA.

Dash No.	N Dia ±.015 (0.4)	Dash No.	N Dia ±.015 (0.4)
08	.468 (11.9)	24	1.484 (37.7)
10	.593 (15.1)	25	1.577 (40.1)
12	.718 (18.2)	27	1.640 (41.7)
13	.765 (19.4)	28	1.687 (42.8)
14	.844 (21.4)	29	1.765 (44.8)
15	.890 (22.6)	30	1.890 (48.0)
16	.968 (24.6)	31	1.953 (49.6)
17	1.015 (25.8)	32	1.968 (50.0)
18	1.093 (27.8)	33	2.077 (52.8)
19	1.140 (29.0)	35	2.140 (54.4)
20	1.203 (30.6)	36	2.187 (55.5)
21	1.265 (32.1)	40	2.406 (61.1)
22	1.343 (34.1)	44	2.656 (67.5)
23	1.453 (36.9)	48	3.031 (77.0)
		118	.310 (7.9)

TABLE VII: STYLE A RING DIA.

Dash No.	N Dia ±.015 (0.4)	Dash No.	N Dia ±.015 (0.4)
095	.312 (7.9)	109	1.266 (32.2)
100	.391 (9.9)	209	1.312 (33.3)
101	101.516 (13.1)	110	1.438 (36.5)
102	102.583 (14.8)	210	1.438 (36.5)
103	103.641 (16.3)	111	1.521 (38.6)
104	104.708 (18.0)	211	1.536 (39.0)
105	105.766 (19.5)	112	1.641 (41.7)
205	205.788 (20.0)	113	1.766 (44.9)
106	106.896 (22.2)	213	1.812 (46.0)
206	206.907 (23.0)	114	1.891 (48.0)
107	1071.016 (25.8)	214	1.938 (49.2)
207	2071.025 (26.0)	115	2.078 (52.8)
108	1081.141 (29.0)	116	2.406 (61.1)
308	3081.188 (30.2)	117	2.510 (63.8)
208	2081.203 (30.6)		



TG70 Connector Strap Wrench With 3/8" Square Drive

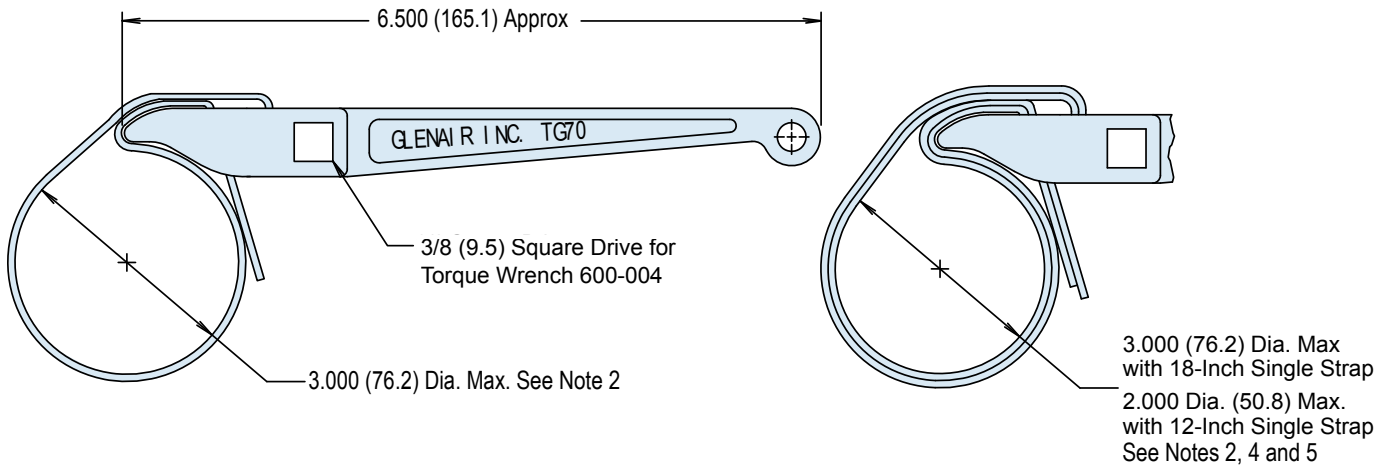

Basic Part Number
Torque Wrench
(Omit for None)

TG70 - 1 - 18

Strap Length in Inches (See Notes 2 and 4)
Lengths Available: 12, 18, 24 and 36-Inch Only
Standard length is 12 Inches,
Omit Dash Number for Standard

- ### APPLICATION NOTES
- These wrenches are made of the following materials:
Wrench Handle - Aluminum Alloy/Nickel Plate.
Wedge - Stainless Steel/Passivated.
Strap - Impregnated Fabric. Straps are 1/2 inch (12.7) in width.
 - Replacement straps are available. Specify part number G70515-xx for 12, 18, 24 or 36-inch strap. 24 and 36 inch for double wrap.
 - Metric dimensions (mm) are indicated in parentheses.
 - Double wrap as shown for heavy duty range.
 - Not recommended for composite coupling nuts (use 600-091 or 600-157).

VARIANCE CHART

TG-70 Strap Wrench Used with Glenair Torque Wrenches

Accessory Shell Size	Recommended Installation Torque			
	Light/Medium Duty ± 5 Inch Pounds		Heavy Duty ± 5 Inch Pounds	
	TG70 Torque	Part Torque	TG70 Torque	Part Torque
08/09	28	35	45	60
10/11	28	35	70	80
12/13	30	40	75	110 [80]
14/15	30	40	75	120 [80]
16/17	30	40	75	120 [80]
18/19	30	40	75	120 [80]
20/21	75	80	95	140 [100]
22/23	75	80	120*	140
24/25	75	80	120*	140
28			135*	150
32			150*	150
36			150*	150

* TG70 Not Recommended For Values of 120 Inch Lbs. or Greater.

- ### VARIANCE CHART NOTES
- Recommended installation torque is approximately 80% of MIL-C-85049 accessory thread strength values.
 - Heavy duty installation torque values may be difficult to attain with the TG70 Strap Wrench; the values shown in brackets [] are the maximum attainable with the TG70 Strap Wrench using a single wrap.
 - Glenair recommends using 600 series torque tools whenever possible. When torque loading exceeds 75 inch pounds, or to attain the heavy duty torque values shown, a double wrap strap provides suitable friction to achieve torque values.
 - Glenair recommends that heavy duty torque values be directly read through the connector shell body with the use of 600-005 connectors holding tools.

Fast, Cost-Effective Shielding Termination

The **BAND-IT**® clamping system provides quick, easy, cost-effective and highly reliable termination of braided metallic shielding or fabric braid. Two sizes of banding tools and bands (bands are also available in standard and extended lengths) allow complete flexibility in terminating EMI shielding and protective mechanical braiding to fiber optic and electrical harnesses. Glenair's complete line of **BAND-IT**® products are in stock and ready for immediate shipment.



Hand Banding Tool 600-058

The 600-058 Hand Banding Tool weighs 1.18 lbs., and is designed for standard clamping bands 600-052 and 600-090 (see page 36) in a tension range from 100 to 180 lbs. Calibrate at 150 lbs. ± 5 lbs. for most shield terminations. Tool and band should never be lubricated.

Reference: **BAND-IT**® part number A40199.

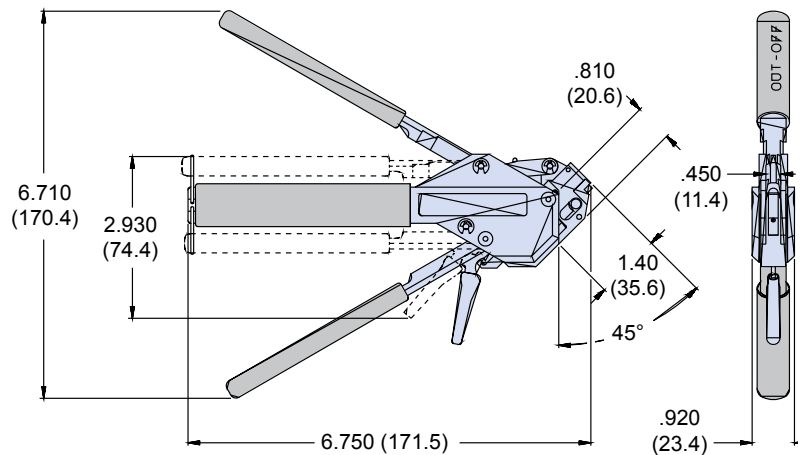

Hand Micro Banding Tool

600-061

The 600-061 Hand Micro Banding Tool weighs 1.18 lbs., and is designed for micro clamping bands 600-057 and 600-083 (see page 36) in a tension range from 50 to 85 lbs. Calibrate at 75lbs +2 lbs. -7 lbs. for most shield terminations. Tool and band should never be lubricated.

Reference: **BAND-IT**® part number A30199.

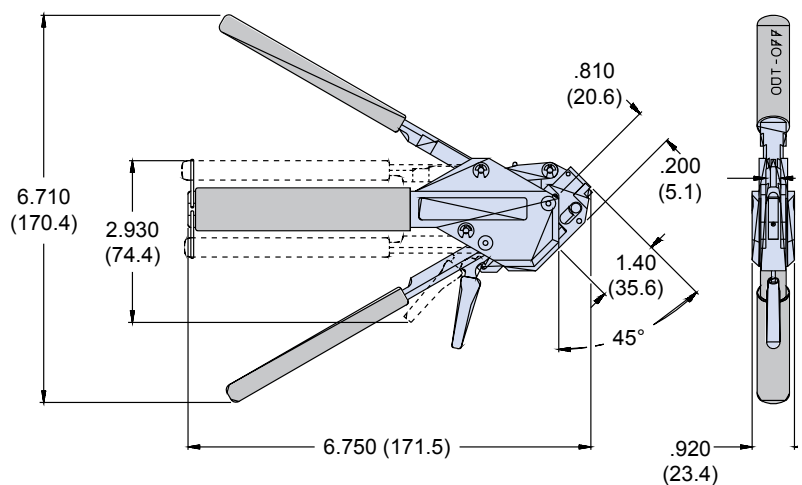

Standard Band 600-052 and Precoiled Standard Band 600-052-1

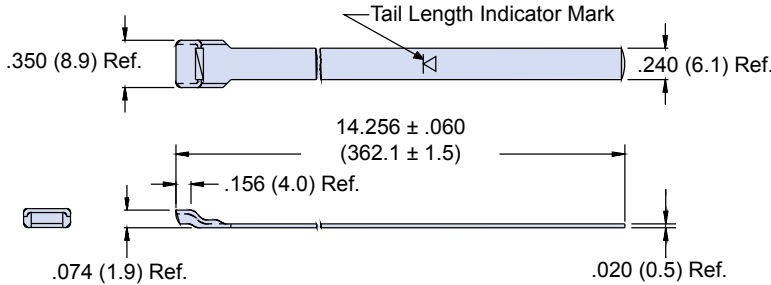

The 600-052 Standard Band is precision constructed of 300 Series SST/Passivate and designed for use with the 600-058 Hand Banding Tool or the 600-067 Pneumatic Banding Tool. Double-wrapped bands will accommodate diameters up to approximately 1.8 inches (45.7). Bands may be ordered flat (600-052) or precoiled (600-052-1). Bands come bagged and tagged in quantities from 1 to 100.

Reference: **BAND-IT®** Part Number A10086

Extended-Length Standard Band 600-090 and Precoiled Extended-Length Standard Band 600-090-1

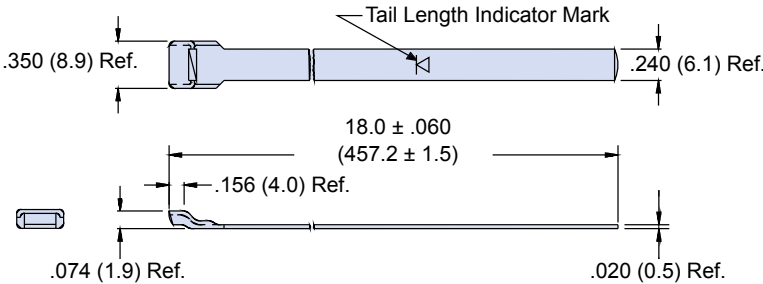

The 600-090 Extended Length Standard Band is precision constructed of 300 Series SST/Passivate, and designed for use with the 600-058 Hand Banding Tool or the 600-067 Pneumatic Banding Tool. Double-wrapped bands will accommodate diameters up to approximately 2.5 inches (63.5). Bands may be ordered flat (600-090), or precoiled (600-090-1). Bands come bagged and tagged in quantities from 1 to 100.

Reference: **BAND-IT®** Part Number A11086

Micro-Band 600-057 Precoiled Micro-Band 600-057-1

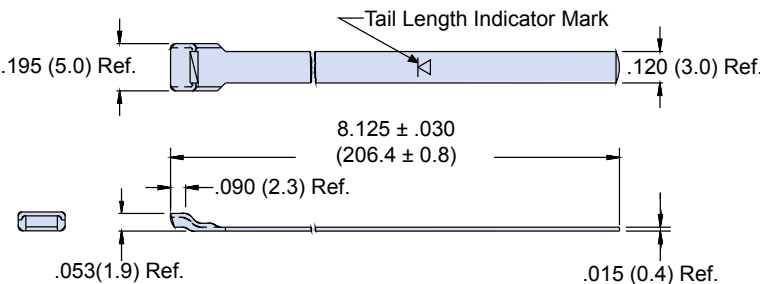

The 600-057 Micro Band is precision constructed of 300 Series SST/Passivate, and designed for use with the 600-061 Hand Banding Tool or the 600-068 Pneumatic Banding Tool. Double-wrapped bands will accommodate diameters up to approximately .88 inches (22.4). Bands may be ordered flat (600-057), or precoiled (600-057-1). Bands come bagged and tagged in quantities from 1 to 100.

Reference: **BAND-IT®** Part Number A31186

Extended Length Micro-Band 600-083 Precoiled Micro-Band 600-083-1

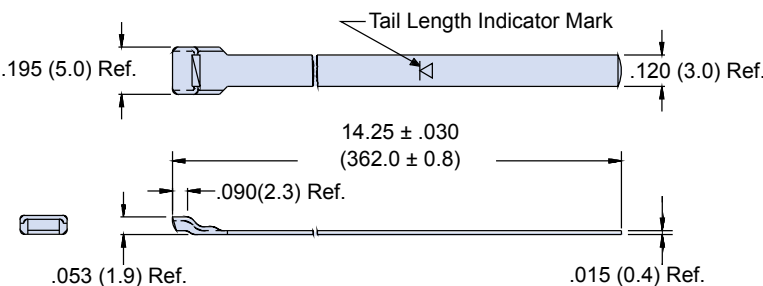

The 600-083 Extended Length Micro-Band is precision constructed of 300 Series SST/Passivate, and designed for use with the 600-061 Hand Banding Tool or the 600-068 Pneumatic Banding Tool. Double-wrapped bands will accommodate diameters up to approximately 1.88 inches (47.8). Bands may be ordered flat (600-083), or precoiled (600-083-1). Bands come bagged and tagged in quantities from 1 to 100.

Reference: **BAND-IT®** Part Number A31089.

Metric dimensions (mm) are indicated in parentheses. Consult factory for diameters above 2.5 inches (63.5).

The BAND-IT® Clamping System EMI Shield Termination Instructions



1. Prepare cable braid for termination process (Figure 1).
2. Push braid forward over adapter retention lip to the adapter incline point (or .4" [10.2mm] minimum braid length). Milk braid as required to remove slack and ensure a snug fit around the shield termination area (Figure 2).

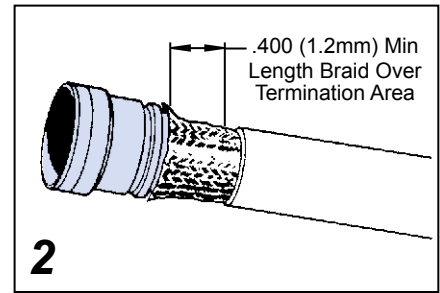
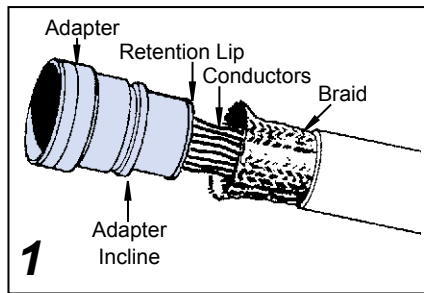

3. Prepare the band in the following manner:

IMPORTANT: Due to Connector/Adapter circumference, it may be necessary to prepare the band around the cable or retention area.

- A. Roll band through the buckle slot twice (bands must be double-coiled).

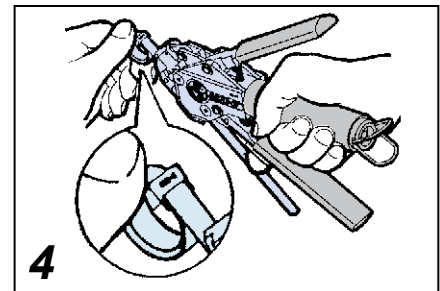
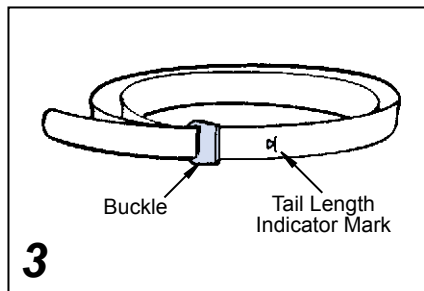

- B. Pull on band until mark (▷) is within approximately .250 inch (6.4mm) of buckle slot (Figure 3). The band may be tightened further if desired.

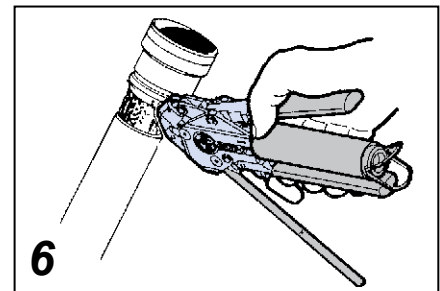
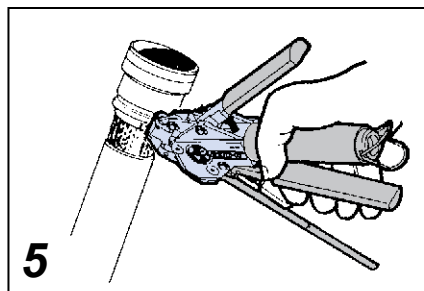

NOTE: Prepared band should have (▷) mark visible as shown in Figure 3.

Shield Termination Clamping Process (Figures 4 thru 8)

NOTE: To free tool handles, move holding clips to center of tool.

4. Squeeze gripper release lever and insert band into the front end opening of the tool (NOTE: Circular portion of looped band must always face downward).
5. Aligning the band and tool with the shield termination area, squeeze black pull-up handle repeatedly using short strokes until it locks against tool body. (This indicates the band is compressed to the tool precalibrated tension).

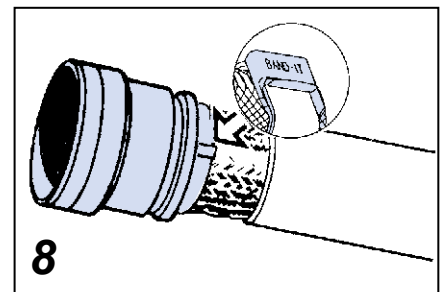
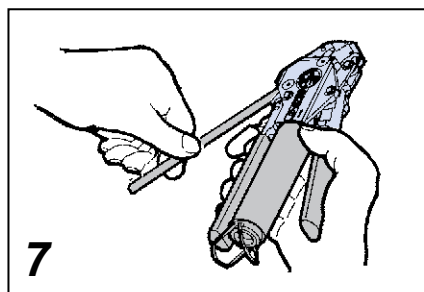

NOTE: If alignment of band and shield is unsatisfactory, tension on band can be relaxed by pushing on slotted release lever on top of tool. Make adjustments as necessary and again, squeeze black pull-up handle.

6. Complete the clamping process by squeezing the gray cut-off handle.
7. Remove excess band from tool and dispose.
8. Inspect shield termination.

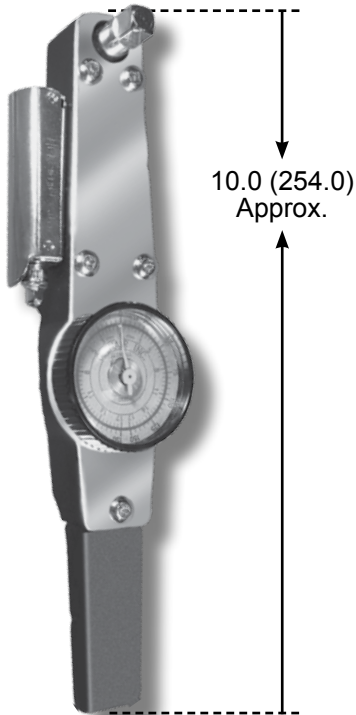

600-004

Hand-Held Torque Wrench

With Lighted Electric Signal

Adjustable to desired torque level of
0 to 150 inch pounds.

3/8" Drive

Requires two Panasonic SR44W
or equivalent batteries

600-007

Bench-Mounted Torque Wrench

With Audible Electric Signal

Adjustable to desired torque level
of 0 to 150 inch pounds.

3/8" Drive

Requires one Panasonic SR44W
or equivalent battery

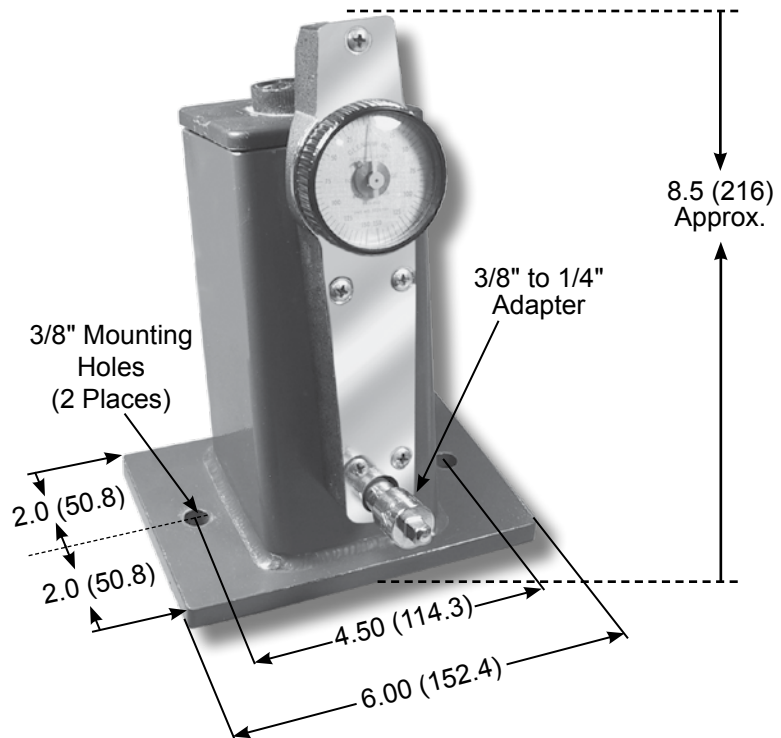

Metric Dimensions (mm) are indicated in parentheses.

H

600-161 Digital Torque Wrench and 600-162 Bench Stand



DIGITAL TORQUE WRENCH AND BENCH STAND

Torque Wrench 600-161

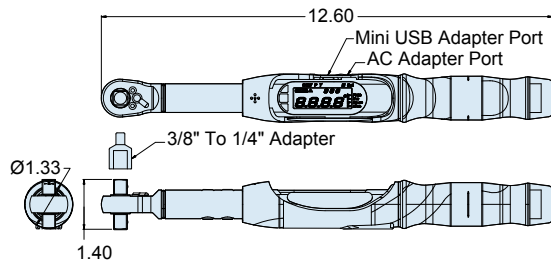

Digital Readout For Improved Accuracy

The Glenair Dual Drive Digital Torque Wrench (600-161) features a dual sided drive head for hand or bench mount use. Features an ergonomic handle with built-in digital readout display. Available torque units include: Ft-lb, Nm, Kg-Cm, or In-lb. Peak and Track modes available. Data collection via supplied USB and software provides quality departments the ability to track and record individual torque values.



1. Use in conjunction with glenair connector and backshell tools
2. Torque range: 15-300 in/lbs; digital graduations 1/10 in/lb;
3. Accuracy: cw/ccw $\pm 2\%$ of reading 10% to 100% of full scale
4. replacement battery: AA x 2

5. USB cable, datatracking software, AC adapter, and 3/8" to 1/4" drive adapter included
6. weight: 1.45 Lb, w/case 2.28 Lb

Bench Stand 600-162

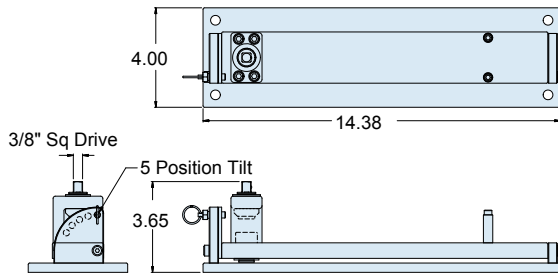

Horizontal Bench Stand

Constructed from aluminum the bench mount (600-162) features five position tilt settings.

1. Use in conjunction with glenair 600-161 digital torque wrench
2. Material: aluminum, steel, bronze weight: 4.62 Lb

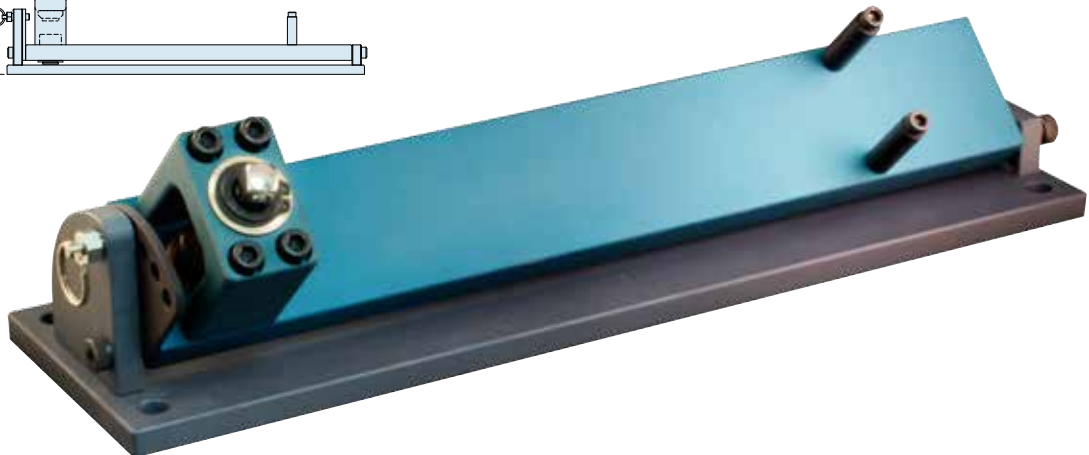



600F005
Connector Holding Tool
 MIL-DTL-38999 Series I
 Plug and Receptacle

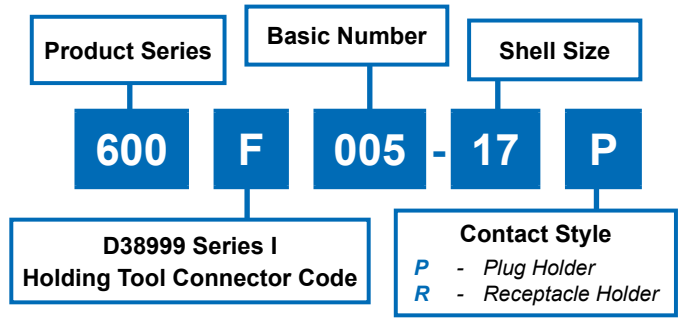

NO POLARIZATION REQUIRED

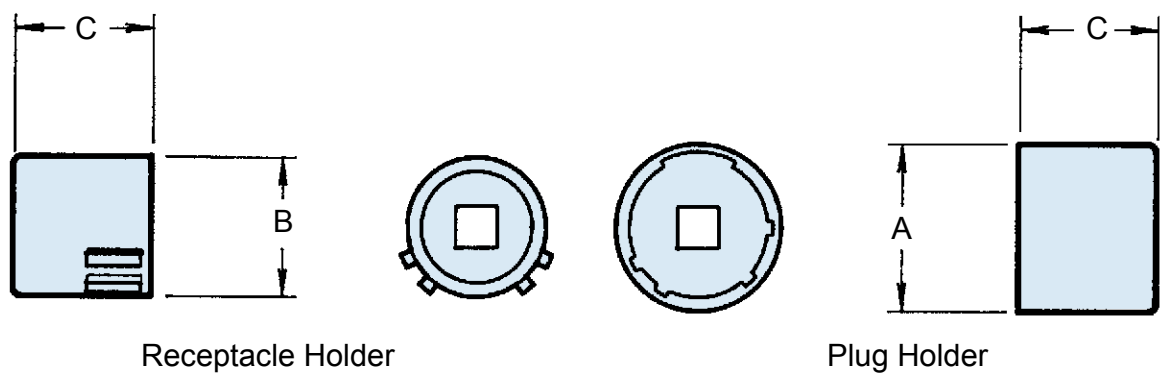

Shell Size	Max. Recommended Torque (Inch Pounds)	A Dia. Max.	B Dia. Max.	C Dim. Max.
09	40	.577 (14.7)	.438 (11.1)	1.031 (26.2)
11	40	.709 (18.0)	.566 (14.4)	1.031 (26.2)
13	40	.829 (21.1)	.678 (17.2)	1.031 (26.2)
15	40	.954 (24.2)	.803 (20.4)	1.031 (26.2)
17	40	1.107 (28.1)	.928 (23.6)	1.031 (26.2)
19	40	1.190 (30.2)	1.033 (26.2)	1.031 (26.2)
21	80	1.315 (33.4)	1.158 (29.4)	1.031 (26.2)
23	80	1.440 (36.6)	1.283 (32.6)	1.031 (26.2)
25	80	1.565 (39.8)	1.408 (35.8)	1.031 (26.2)

NOTES

1. Metric dimensions (mm) are indicated in parentheses.
2. Material: Case hardened carbon steel with electroless nickel finish.
3. Receptacle and plug holder drives: 1/4" - Shell sizes 09, 11 and 13; 3/8" - Shell sizes 15 and up.

600FF005
Connector Holding Tool
MIL-DTL-38999 Series II
Plug and Receptacle

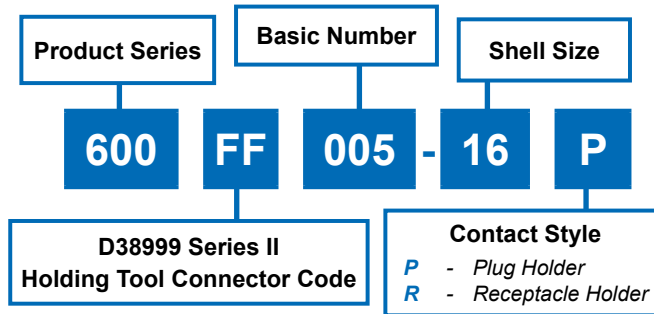

NO POLARIZATION REQUIRED

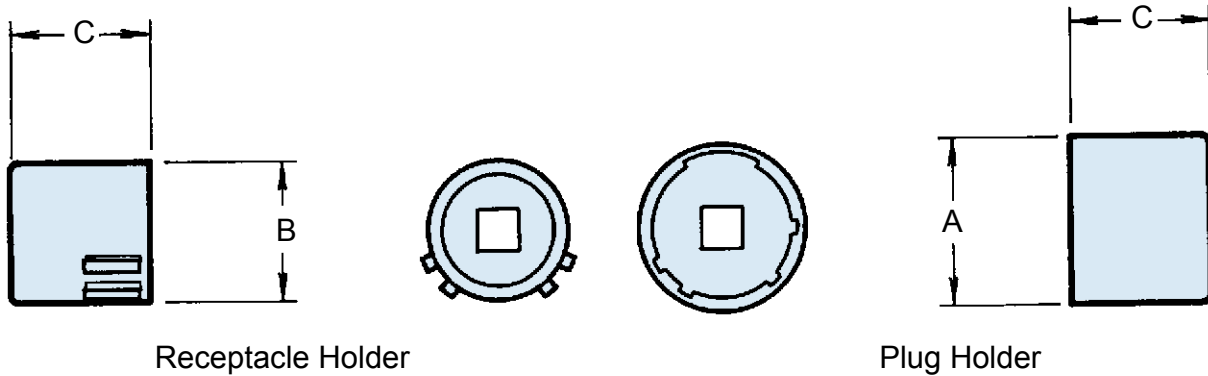

Shell Size	Max. Recommended Torque (Inch Pounds)	A Dia. Max.	B Dia. Max.	C Dim. Max.
08	40	.478 (12.1)	.358 (9.1)	.910 (23.1)
10	40	.599 (15.2)	.486 (12.3)	.910 (23.1)
12	40	.758 (19.3)	.603 (15.3)	.910 (23.1)
14	40	.882 (22.4)	.728 (18.5)	.910 (23.1)
16	40	1.007 (25.6)	.853 (21.7)	.910 (23.1)
18	40	1.133 (28.8)	.958 (24.3)	.910 (23.1)
20	80	1.257 (31.9)	1.083 (27.5)	.910 (23.1)
22	80	1.382 (35.1)	1.208 (30.7)	.910 (23.1)
24	80	1.507 (38.3)	1.333 (33.9)	.910 (23.1)

NOTES

1. Also mates with 40M38277.
2. Metric dimensions (mm) are indicated in parentheses.
3. Material: Case hardened carbon steel with electroless nickel finish.
4. Receptacle and plug holder drives: 1/4" - Shell sizes 08, 10 and 12; 3/8" - Shell sizes 14 and up.



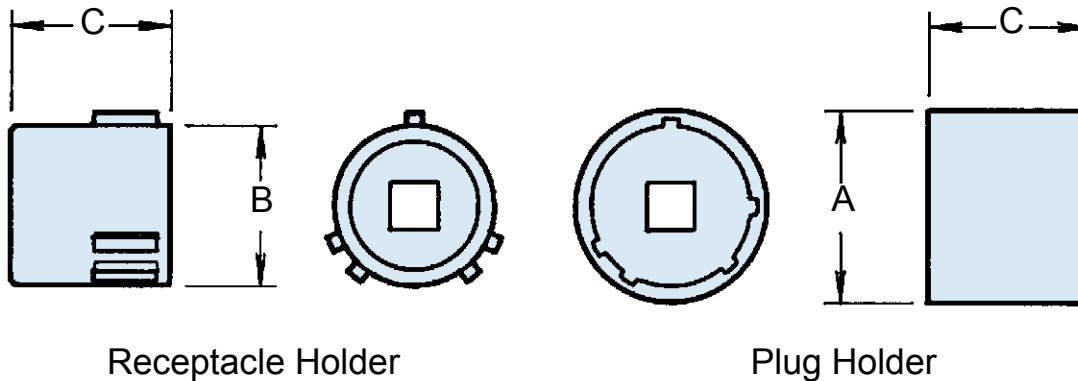
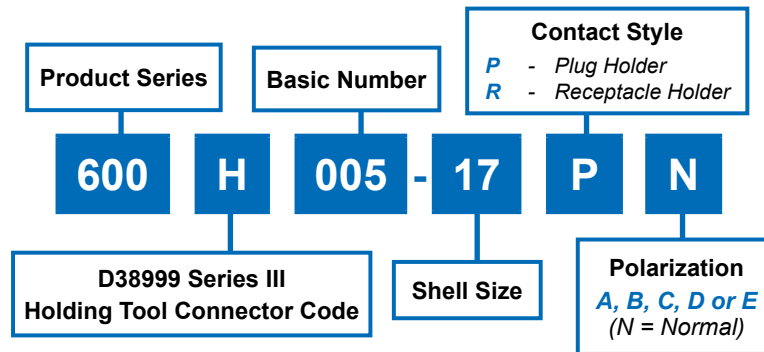

Shell Size		Recommended Torque (+/- 5 Inch-Pounds)		A Dia. Max.	B Dia. Max.	C Dim. Max.
Com'l	Mil. Ref.	Metal	Composite			
09	A	60	35	.577 (14.7)	.438 (11.1)	1.031 (26.2)
11	B	80	35	.709 (18.0)	.566 (14.4)	1.031 (26.2)
13	C	110	40	.829 (21.1)	.678 (17.2)	1.031 (26.2)
15	D	120	40	.954 (24.2)	.803 (20.4)	1.031 (26.2)
17	E	120	40	1.107 (28.1)	.928 (23.6)	1.031 (26.2)
19	F	120	40	1.190 (30.2)	1.033 (26.2)	1.031 (26.2)
21	G	140	80	1.315 (33.4)	1.158 (29.4)	1.031 (26.2)
23	H	140	80	1.440 (36.6)	1.283 (32.6)	1.031 (26.2)
25	J	140	80	1.565 (39.8)	1.408 (35.8)	1.031 (26.2)

NOTES

1. Metric dimensions (mm) are indicated in parentheses.
2. Material: Case hardened carbon steel with electroless nickel finish.
3. Receptacle and plug holder drives: 1/4" - Shell sizes 09, 11 and 13; 3/8" - Shell sizes 15 and up.
4. Composite values apply when using Glenair 600-091 and 600-007 tools.

600HH005
Connector Holding Tool
MIL-DTL-38999 Series IV
Plug and Receptacle

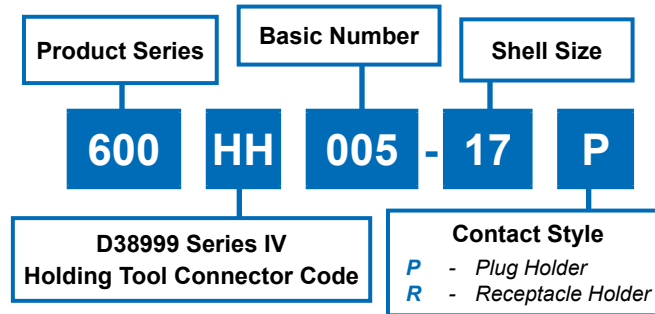

NO POLARIZATION REQUIRED

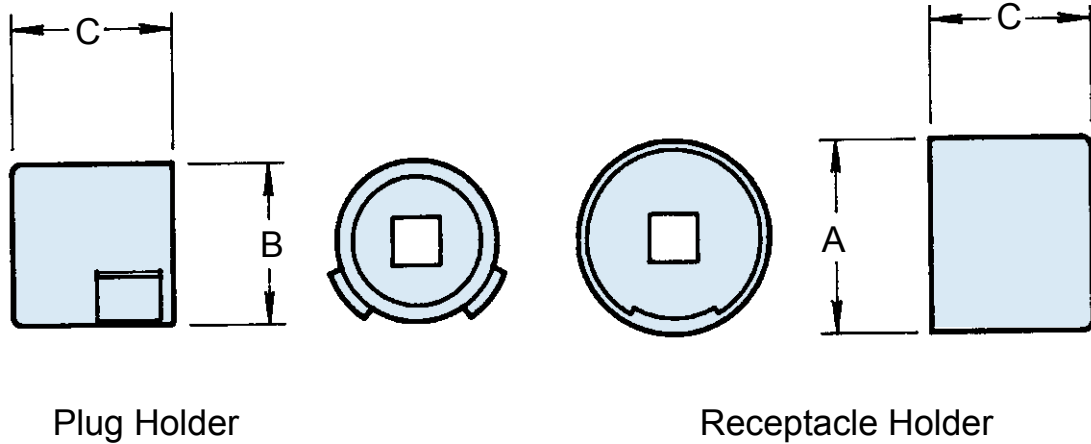

Shell Size		Max. Recommended Torque (Inch Pounds)	A Dia. Max.	B Dia. Max.	C Dim. Max.
Com'l	Mil. Ref.				
11	B	80	.83 (21.1)	.515 (13.1)	1.28 (32.5)
13	C	110	.95 (24.1)	.650 (16.5)	1.28 (32.5)
15	D	120	1.07 (27.2)	.775 (19.7)	1.28 (32.5)
17	E	120	1.20 (30.5)	.901 (22.9)	1.28 (32.5)
19	F	120	1.28 (32.5)	1.015 (25.8)	1.28 (32.5)
21	G	140	1.40 (35.6)	1.140 (29.0)	1.28 (32.5)
23	H	140	1.53 (38.9)	1.265 (32.1)	1.28 (32.5)
25	J	140	1.66 (42.2)	1.392 (35.4)	1.28 (32.5)

NOTES

1. Metric dimensions (mm) are indicated in parentheses.
2. Material: Case hardened carbon steel with electroless nickel finish.
3. Receptacle and plug holder drives: 1/4" - Shell sizes 11 and 13; 3/8" - Shell sizes 15 and up.



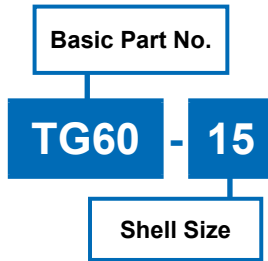

NOTES

1. Metric dimensions (mm) are indicated in parentheses.
2. Material: Aluminum alloy with electroless nickel finish.

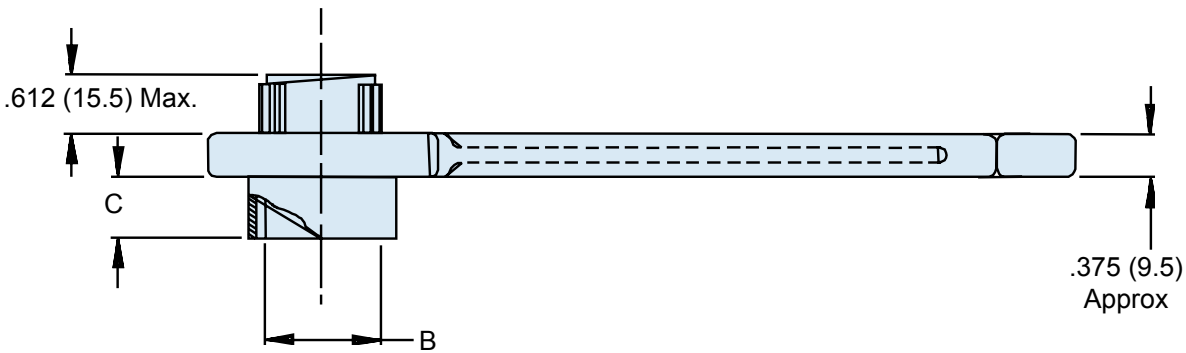
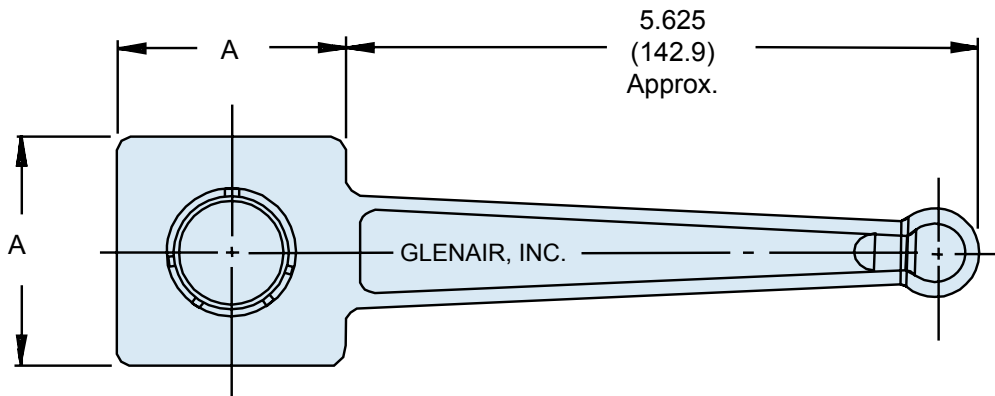

Shell Size	A Dim. Ref.	B Dia. Ref.	C Max
9	1.250 (31.8)	.442 (11.2)	.647 (16.4)
11	1.250 (31.8)	.570 (14.5)	.647 (16.4)
13	1.250 (31.8)	.687 (17.4)	.647 (16.4)
15	2.000 (50.8)	.812 (20.6)	.647 (16.4)
17	2.000 (50.8)	.937 (23.8)	.647 (16.4)
19	2.000 (50.8)	1.042 (26.5)	.647 (16.4)
21	2.000 (50.8)	1.167 (29.6)	.617 (15.7)
23	2.000 (50.8)	1.292 (32.8)	.617 (15.7)
25	2.000 (50.8)	1.417 (36.0)	.617 (15.7)

TG48
Universal Connector Holding Wrench
 MIL-DTL-38999 Series II

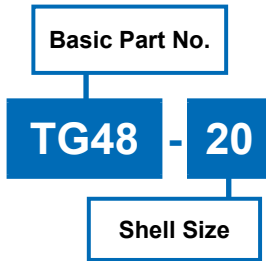

NOTES

1. Metric dimensions (mm) are indicated in parentheses.
2. Material: Aluminum alloy with electroless nickel finish.

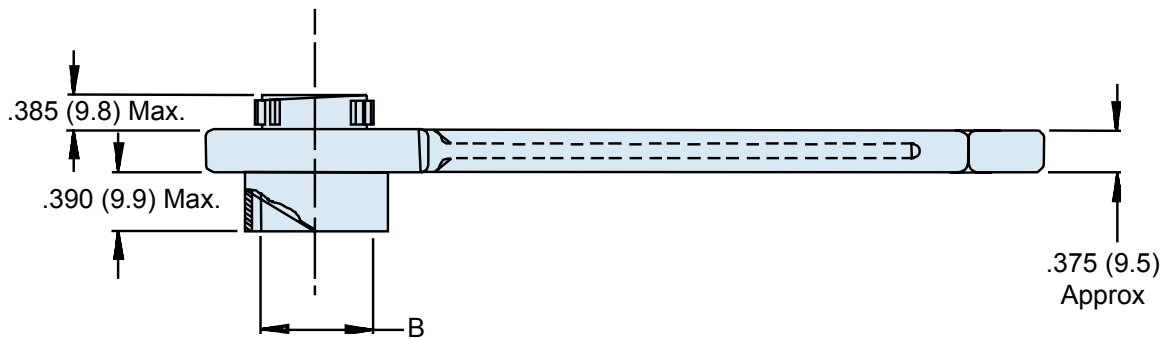
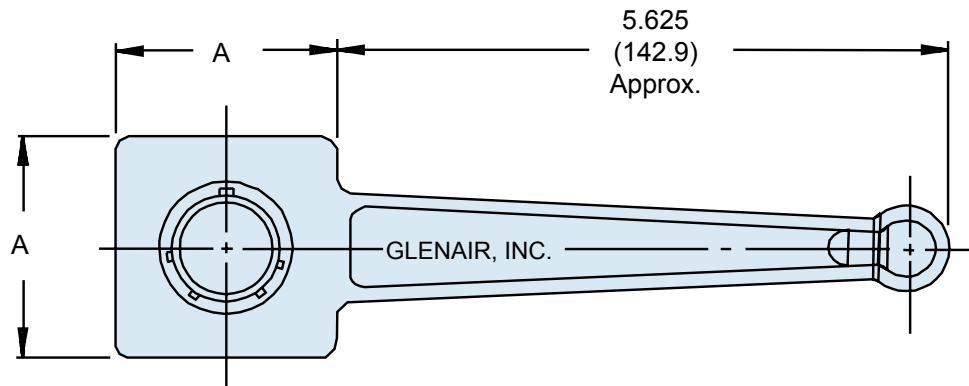

Shell Size	A Dim. ± .062 (1.6)	B Dia. Ref.
8	1.250 (31.8)	.362 (9.2)
10	1.250 (31.8)	.490 (12.4)
12	1.250 (31.8)	.607 (15.4)
14	1.250 (31.8)	.732 (18.6)
16	2.000 (50.8)	.857 (21.8)
18	2.000 (50.8)	.962 (24.4)
20	2.000 (50.8)	1.087 (27.6)
22	2.000 (50.8)	1.212 (30.8)
24	2.000 (50.8)	1.337 (34.0)



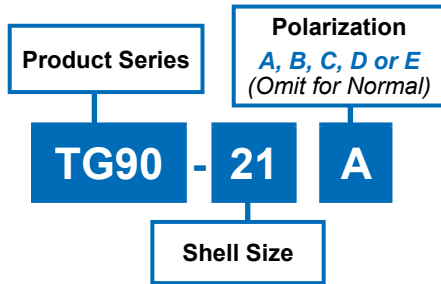

NOTES

1. Metric dimensions (mm) are indicated in parentheses.
2. Material: Aluminum alloy with electroless nickel finish.

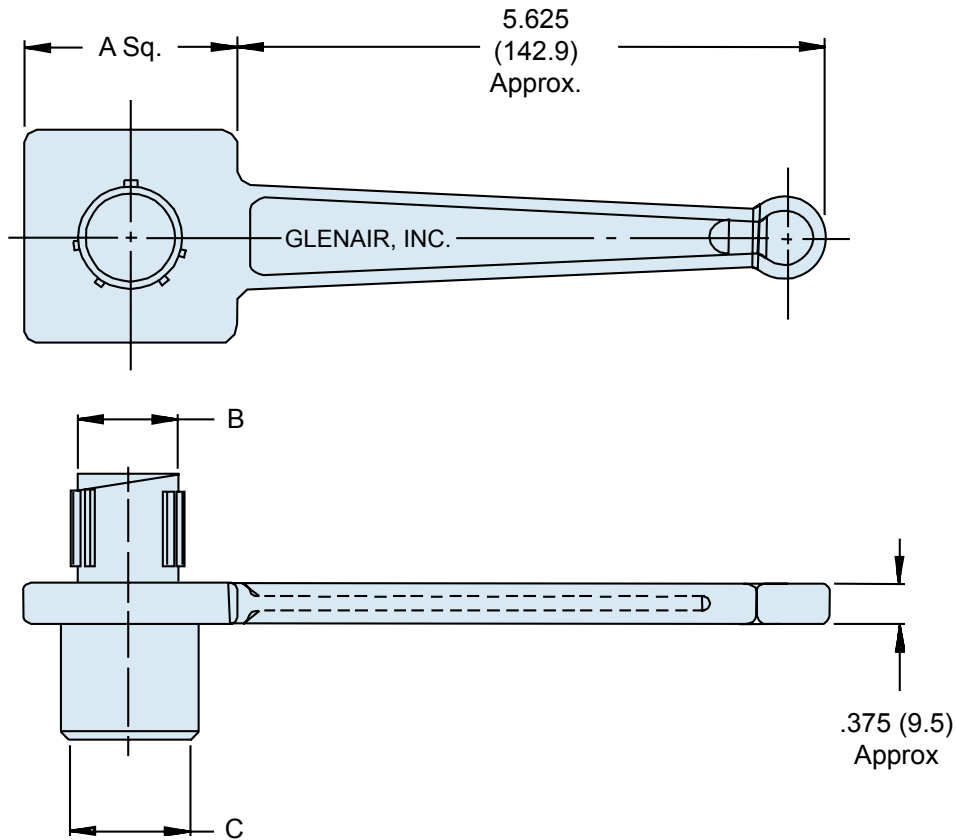

Shell Size	A Dim. ± .062 (1.6)	B Dia. Ref.	C Dia. Ref.
09	1.250 (31.8)	.438 (11.1)	.441 (11.2)
11	1.250 (31.8)	.566 (14.4)	.569 (14.5)
13	1.250 (31.8)	.678 (17.2)	.682 (17.3)
15	2.000 (50.8)	.802 (20.4)	.811 (20.6)
17	2.000 (50.8)	.928 (23.6)	.931 (23.6)
19	2.000 (50.8)	1.032 (26.2)	1.037 (26.3)
21	2.000 (50.8)	1.155 (29.3)	1.162 (29.5)
23	2.750 (69.9)	1.283 (32.6)	1.288 (32.7)
25	2.750 (69.9)	1.407 (35.7)	1.411 (35.8)

600-091 Composite-Hex-Coupling Wrench



ALUMINUM TOOL FOR USE WITH GLENAIR COMPOSITE BACKSHELLS

600 - **091** - **16**

Product Series **Basic Number**

Dash Number
(Table I)
for Individual Sizes

For Kit:
KC - Dash Numbers 08 through 28
KLC - Dash Numbers 32 through 44
KIT - Dash Numbers 08 through 44

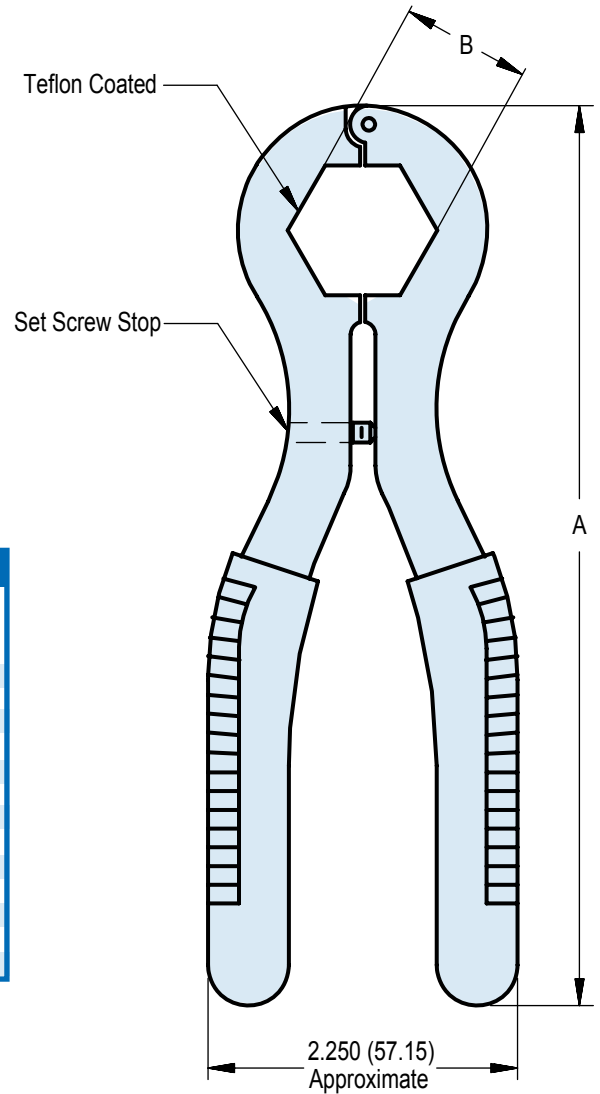

TABLE I: DASH NUMBER AND DIMENSIONS

Dash No.	A Ref.	B +/- .005 (.13) Hex*	Shell Size Ref.	Composite Torque Inch Pounds
08	7.38 (187.5)	.750 (19.1)	08/09	40
10	7.50 (190.5)	.875 (22.2)	10/11	40
12	7.50 (190.5)	1.000 (25.4)	12/13	40
14	7.50 (190.5)	1.125 (28.6)	14/15	40
16	7.50 (190.5)	1.250 (31.8)	16/17	40
18	7.75 (196.9)	1.375 (34.9)	18/19	40
20	8.00 (203.2)	1.500 (38.1)	20/21	80
22	8.25 (209.6)	1.625 (41.3)	22/23	80
24	8.25 (209.6)	1.750 (44.5)	24/25	80
28	8.50 (215.9)	2.000 (50.8)	28	120
32	10.00 (254.0)	2.250 (57.2)	32	120
36	10.00 (254.0)	2.500 (63.5)	36	120
44	10.00 (254.0)	3.000 (76.2)	44	160

APPLICATION NOTES

1. This backshell assembly tool is designed for Glenair composite hex coupling applications and should be used in conjunction with Glenair torque wrenches (see page 14).
2. These wrenches are made of aluminum alloy with vinyl grips.
3. B Hex is critical, adjust set screw until dimension is within tolerance (+/- .005)
4. Metric dimensions (mm) are indicated in parentheses.



600-157 Composite-Hex-Coupling Wrench

STAINLESS STEEL TOOL FOR USE WITH GLENAIR COMPOSITE BACKSHELLS

600
Product Series

157
Basic Number

K
Dash Number for Individual Wrench or:
*K - All Wrench Sizes
08 through 24, No Case*
*KC - All Wrench Sizes
08 through 24 with Case*

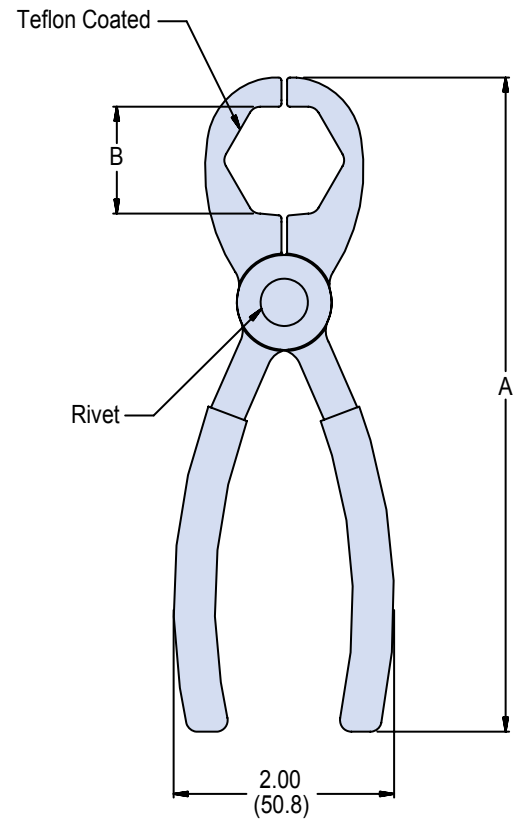
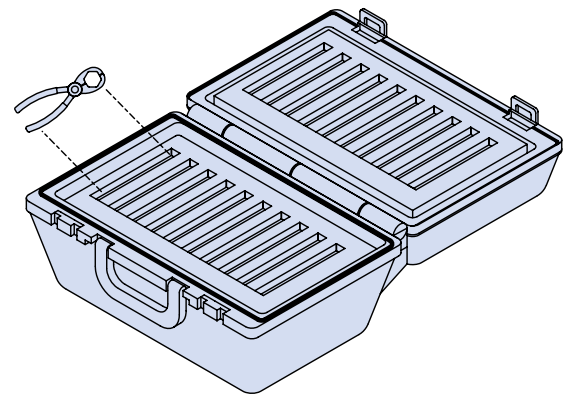

TABLE I: DASH NUMBER				
Dash Number	A Ref	B Hex ±.005 (0.1)	Connector for Shell Size	
			Codes A & F	Code H
08	6.700 (170.2)	.750 (19.1)	08	09
10	6.750 (171.5)	.875 (22.2)	10	11
12	6.810 (173.0)	1.000 (25.4)	12	13
14	6.880 (174.8)	1.125 (28.6)	14	15
16	6.950 (176.5)	1.250 (31.8)	16	17
18	7.050 (179.1)	1.375 (34.9)	18	19
20	7.150 (181.6)	1.500 (38.1)	20	21
22	7.380 (187.5)	1.625 (41.3)	22	23
24	7.440 (189.0)	1.750 (44.5)	24	25

- ### APPLICATION NOTES
1. This backshell assembly tool is designed for Glenair composite hex coupling applications and should be used in conjunction with Glenair torque wrenches (see page 14).
 2. These wrenches are made of stainless steel with vinyl grips.
 3. Metric dimensions (mm) are indicated in parentheses.



H

The world's broadest selection of interconnect products—in stock and ready for immediate same-day shipment

Glenair's World of Interconnect Solutions

A complete overview of Glenair's innovative range of interconnect products and services, including Military Standard and commercial equivalent connectors and accessories.

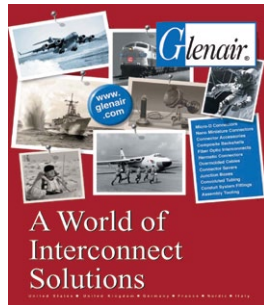

Micro-D Twistpin Connectors and Accessories

Glenair offers both Military Standard 83513 Micro-D connectors as well as COTS selections, backshells, mounting hardware and more. Our TwistPin contact provides superior performance.

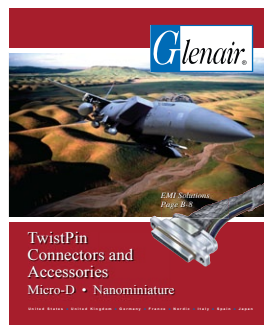

EMI/EMP Filter Connectors

MIL-DTL-38999 type EMI/EMP filter connectors, as well as other Military Standard and commercial electromagnetic shielding technologies. Also includes Glenair Series 80 "Mighty Mouse" filter products.



Fiber Optic Interconnect Solutions

Tactical fiber optic connectors, cables, and termini for airframe, shipboard, and military ground vehicles. Catalog features Glenair's innovative high-density (GHD) connector system for reduced size and weight applications.



Available now: Glenair's **Interconnect Product Guide CD**, featuring our entire library of Glenair catalogs and data sheets.

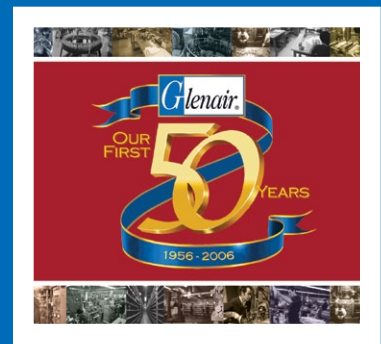

In addition to over a dozen product line catalogs, the CD includes a powerful part number development program that takes all the pain and confusion out of ordering interconnect components. An easy-to-use inventory search program provides ready access to 60,000 MIL-STD and commercial part numbers.

Composite Thermoplastic Interconnect Solutions

Glenair is the world's leading manufacturer of composite interconnect solutions. We are the 'go-to' supplier for advanced composite technologies for commercial and military interconnect applications.

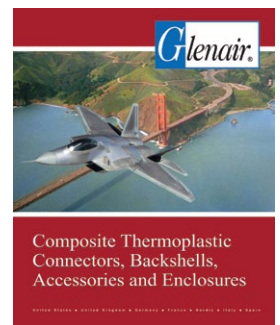

Military Standard Connector Accessories

If the MS connector accessory you need isn't in here – it doesn't exist. Search this easy-to-use catalog by accessory type or Mil-Spec slash number, then place your order against Glenair's 60,000 part number same-day inventory.



Series 80 "Mighty Mouse" Connectors and Cables

Glenair's revolutionary connector series that reduces interconnect system size and weight by 50% compared to standard MIL-DTL-38999 connectors. Now used on hundreds of mission-critical military and commercial applications.

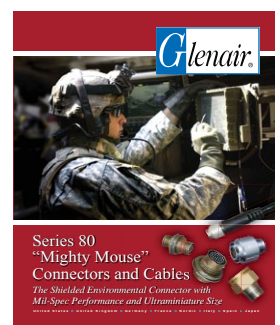

Visit us at www.glenair.com and use the literature order form for immediate catalog fulfillment



Out of This World
**INTERCONNECT
SOLUTIONS**

Glenair, Inc.

1211 Air Way • Glendale, California • 91201-2497
Telephone: 818-247-6000 • Fax: 818-500-9912 • sales@glenair.com
www.glenair.com

**Glenair Power
Products Group**

860 N. Main Street Extension
Wallingford, CT
06492

Telephone:
203-741-1115
Facsimile:
203-741-0053
sales@glenair.com

Glenair UK Ltd

40 Lower Oakham Way
Oakham Business Park
P.O. Box 37, Mansfield
Notts, NG18 5BY England

Telephone:
+44-1623-638100
Facsimile:
+44-1623-638111
sales@glenair.co.uk

Glenair Microway Systems

7000 North Lawndale Avenue
Lincolnwood, IL
60712

Telephone:
847-679-8833
Facsimile:
847-679-8849

Glenair Nordic AB

Gustav III : S Boulevard 46
S - 169 27 Solna
Sweden

Telephone:
+46-8-50550000
Facsimile:
+46-8-50550001
sales@glenair.se

Glenair Electric GmbH

Schaberweg 28
D. 61348 Bad Homburg
Germany

Telephone:
06172 / 68 16 0
Facsimile:
06172 / 68 16 90
germany@glenair.com

Glenair Iberica

C/ La Vega, 16
45612 Velada
Spain

Telephone:
+34-925-89-29-88
Facsimile:
+34-925-89-29-87
sales@glenair.es

Glenair Italia S.p.A.

Via Del Lavoro, 7
40057 Quarto Inferiore –
Granarolo dell'Emilia
Bologna, Italy

Telephone:
+39-051-782811
Facsimile:
+39-051-782259
info@glenair.it

Glenair France SARL

7, Avenue Parmentier
Immeuble Central Parc #2
31200 Toulouse
France

Telephone:
+33-5-34-40-97-40
Facsimile:
+33-5-61-47-86-10
sales@glenair.fr

