

**G**lenair®



# Economical, High-Performance Conduit Wire Protection Systems

*Fittings and Materials for User-Installable Systems*

United States ■ United Kingdom ■ Germany ■ France ■ Nordic ■ Italy ■ Spain ■ Japan

May 2011

# CONDUIT SYSTEMS



## From 0 to 60 in 3.9 Seconds

**H**igh voltage electrical power distribution is a critical component of the 100% electric Tesla Roadster. The reliable distribution of electrical energy from the car's lithium-ion energy storage system to the vehicle's motor, electronic control module, HVAC system, transmission and regenerative braking unit depends on a high-performance wiring system made up of high-temperature shielded conduit and ruggedized reverse-bayonet power connectors—all made by Glenair.

Glenair is on the forefront of innovative efforts to advance the reliability and performance of electric vehicles. Glenair power connectors, cables and conduit are deployed in high-voltage power management and distribution applications for systems as demanding as military vehicles --and as fast as the Tesla Roadster.



1211 Air Way · Glendale, California 91201-2497  
Tel: 818-247-6000 · Fax: 818-500-9912 · E-mail: [sales@glenair.com](mailto:sales@glenair.com) · [www.glenair.com](http://www.glenair.com)

United States · United Kingdom · Germany · Nordic · France · Italy · Spain · Japan

# User-Installable Series 72 Guardian Annular Conduit System

*Economical, High-Performance Conduit Wire Protection System*

## *The Guardian Series of User-Installable Fittings*

- Economical and easy to install. *It's a snap!*
- General duty, all-purpose wire protection
- O-ring equipped environmental sealing (splash-proof)
- Self-locking coupling nuts
- Band and shrink-boot ready
- Metal and composite thermoplastic materials



## *Available with your choice of Economical Annular Convuluted Tubing*

- Kynar® - Thermally stabilized, chemical and radiation resistant.
- PVDF - Chemical and radiation resistant, available in 5 colors plus black and natural.
- G-FLEX Siltem - Halogen free, low toxicity, low smoke, 175° temperature rating.

### SELECTION GUIDE

1: Select the *Kynar*®, *PVDF*, or *Siltem* annular convuluted tubing core



2: Select from our menu of jacketing and braiding options



3: Select appropriate Guardian adapters, fittings, and transitions



*Easy-To-Install and Economical  
Wire Protection*



# Guardian System

## User-Installable Fittings and Adapters for Series 72 Annular Convolute Tubing

"Y" and "T" transitions in composite thermoplastic and plated metal materials for easy routing of multi-branch wire assemblies

Convolute tubing options in the Guardian system include Kynar®, PVDF, and Siltem

Available jacketing materials include EPDM, Hypalon®, Neoprene, and Viton as well as Duraelectric™ in Black, Gray, and Desert Tan

EMI/RFI shielding options include standard tin/copper braid as well as ArmorLite™ Microfilament metal-clad ultra lightweight braid

A selection of high performance, high temperature plastic convolute tubing is available in a broad range of materials and colors

The Guardian system also includes bulkhead feed-thru adapters for easy routing of wires through non-connectorized bulkheads and boxes

All Guardian system conduit to connector adapters are Banding Platform equipped and optimized for easy EMI shield termination with BAND-IT® banding

All Guardian system adapters are equipped with shrink boot grooves for easy environmental sealing and strain relief

The heart of the Guardian system is its unique retaining clip assembly system, offering high speed assembly without the need for special tools. Environmental O-rings provide splash-proof level environmental sealing.



## Guardian system quick selection guide



121-193  
Conduit with 2 braids and jacket,  
p. 15



712-839  
Metal connector  
adapter, p. 16



710-859  
Double-Y  
transition, p. 28



140-200 Octagonal junction box, p. 50



Factory terminated  
guardian assemblies,  
p. 54-59

Part No.	Description	Page No.
<b>Annular Conduit Cores and Accessory Materials</b>		
120-144	Conduit in 3 materials, Slit and Non Slit	10
600-180	Wire Loom Tool	11
121-190	Conduit with Braid	12
121-191	Conduit with Braid and Jacket	13
121-192	Conduit with 2 Braids	14
121-193	Conduit with 2 Braids and Jacket	15
<b>Guardian Fittings</b>		
712-839	Metal Connector Adapter	16
712M*838	Metal Mighty Mouse Connector Adapter	18
712-852	Metal Bulkhead Feed-Thru Fitting	20
713-356	Composite Connector Adapter	22
713-376	Composite Bulkhead and Junction Box Feed-Thru Fitting	24
<b>Guardian Transitions</b>		
<b>Direct Attachment</b>		
710-858	Y Transition	26
710-859	Double-Y Transition	28
710-860	T Transition	30
710-861	Double-T Transition	32
<b>With H Code Teeth</b>		
713-351	Y Transition	34
713-352	Double-Y Transition	35
713-353	T Transition	36
713-354	Double-T Transition	37
<b>Tools, Bands, Boots and Boxes</b>		
TG69	Soft Jaw Pliers	39
TG70	Connector Strap Wrench	40
600-164	Utility Shear	41
	BAND-IT® Shield Termination System	42
	Environmental Shrink Boots	43-46
	Shrink Boot General Installation Guide	47-49
	Composite Junction Boxes	50-51
712-877	Composite Junction Box Adapter	52
<b>Factory Terminated Assemblies</b>		
	Factory Terminated Guardian Assemblies	54-59
	Turnkey Factory Crimp Assemblies	60



## Series 72 Annular Convoluted Tubing Conduit, Braided Shield, and Jacketing options

### **Guardian system conduit tubing, braided shielding, and jacketing options**

The Guardian System is Glenair's complete solution for your wire routing application. System design begins with your selection of core material, either Kynar, PVDF, or Siltem. Core materials may be outfitted with braided shielding and jacketing options per the type designators listed below to address specific mechanical, electrical (EMI), and environmental protection requirements. See the following pages for detailed how-to-order information.

#### **Part Number 120-144**



Pg. 10

#### **For non-environmental and non-EMI/RFI applications**

Strong, abrasion resistant annular conduit tubing, supplied in thermally stabilized Kynar®, PVDF, or medium duty Siltem. Available in 7 colors, standard or slit.

#### **Part Number 121-190**



Pg. 12

#### **For non-environmental EMI/RFI applications**

Annular conduit tubing with braided shield for EMI/RFI protection and additional structural integrity, particularly pull (tensile) strength.

#### **Part Number 121-191**



Pg. 13

#### **For environmental EMI/RFI applications**

Annular conduit tubing with braided shielding for EMI/RFI protection and a ruggedized jacket for environmental protection against dust, dirt, and moisture incursion.

#### **Part Number 121-192**



Pg. 14

#### **For non-environmental EMI/RFI applications with high dB shielding requirements**

Annular conduit tubing with double braided shield for high frequency EMI/RFI protection and mechanical strength.

#### **Part Number 121-193**



Pg. 15

#### **For environmental EMI/RFI applications with high dB shielding requirements**

Annular conduit tubing with double braided shield and jacket for optimum EMI/RFI protection, strength and environmental sealing.

## Series 72 Annular Convoluted Tubing Conduit, Braided Shield, and Jacketing options



### Tubing Material Choices

Y	Kynar®	Flexible, thermally stabilized, resistant to harsh chemicals and radiation. UV resistant, self-extinguishing, nontoxic and resistant to low-temperatures. 166° C temp. rating.
V	PVDF	Flexible and chemical/radiation resistant. Available in 4 colors plus standard black and natural. 150° C temperature rating.
S	G-FLEX Siltem	Medium duty Halogen free, low toxicity, low smoke. 175° C temperature rating.



### Color Options

	Standard Black	Standard for all Series 72 convoluted tubing materials
N	Natural/Clear	Available for for all Series 72 convoluted tubing materials
R	Red	Available for Kynar and PVDF only
Y	Yellow	Available for Kynar and PVDF only
BL	Blue	Available for Kynar and PVDF only
TN	Desert Tan	Available for Kynar and PVDF only
O	Orange	Available for Kynar and PVDF only

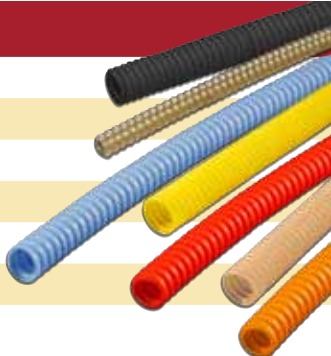

### Braided Shield Options

T	Tin/Copper	150° temperature rating, 125 lbs. tensile strength, 96 hr. salt spray corrosion resistance
C	Stainless Steel	Highest tensile strength (225 lbs.), highest temperature—up to 260°
N	Nickel/Copper	200° temperature rated, 150 lbs. tensile strength, 500 hrs. salt spray corrosion resistance
L	ArmorLite™	Microfilament metal-clad ultra lightweight stainless steel braid
D	Dacron	Yarn with excellent abrasion resistance, good chemical resistance, non-conductive
M	Nomex	-55° to 260° temperature range - will not melt, excellent chemical resistance, non-conductive
E	AmberStrand® 100%	Expandable, flexible, high-strength conductive metal-clad composite thermoplastic
F	AmberStrand® 75%/25%	75% Expandable, flexible, high-strength conductive metal-clad composite thermoplastic combined with 25% nickel-plated 36AWG copper wire for additional strength



### Jacketing Options

N	Neoprene	Tough, durable polychloroprene for mechanical and environmental protection
H	Hypalon®	Light weight with broad temperature range
E	EPDM	Better resistance to Ketones
V	Viton	Heaviest material with best resistance to oil and gasoline
B	Duraelectric, Black	Weatherproof, halogen free, flame resistant, functional to 260°
G	Duraelectric, Gray	Qualified to US Navy MIL-PRF-24758A, Fed Std 595B #26270 Haze Gray color
TN	Duraelectric, Desert Tan	Duraelectric in Fed Std #3446 Desert Tan color



# Introduction to Conduit Interconnect Technologies and Packaging

## Determining Tubing Size

### How to use the tables on this page:

It is possible for a wire bundle to contain wires of all the same size diameter, or a variety of mixed diameters. The gauge provides only the diameter of the conductor, and this information alone is not sufficient to determine required tubing size. Referring to the appropriate wire specification is necessary to establish the overall diameter over the insulation and/or braids.

Step	All Wires Same Diameter	Two Different Wire Diameters
1. A bundle containing 30 wires	30 wires @ .045 dia	15 wires @ .045 dia 15 wires @ .135 dia
2. Determine average wire diameter	$30 \times .045 = 1.35$ $1.35 \div 30 = .045$ average wire diameter	$15 \times .045 = .68$ $15 \times .135 = 2.03$ 2.71 $2.71 \div 30 = .090$ average wire diameter
3. Using Table I, find factor for 30 wires (6.7) and multiply by average wire diameter	$.045 \times 6.7 = .3015$ wire bundle diameter	$.090 \times 6.7 = .603$ wire bundle diameter
4. Tubing size is determined on Table II. 70% fill is recommended	Size 12 (.305 dia = 70% fill)	Size 24 (.607 dia = 70% fill)

Table I																		
Number of Wires	1	2	3	4	5	6	7	8	9	10	12	14	16	18	20	24	28	32
Factor	1.0	2.0	2.2	2.4	2.7	2.9	3.0	3.3	3.8	4.0	4.3	4.6	5.0	5.3	5.6	6.0	6.5	6.9
Number of Wires	36	40	45	50	55	60	65	70	75	80	90	100	125	150	175	200	250	300
Factor	7.4	7.7	8.1	8.5	8.9	9.3	9.7	10.1	10.5	10.9	11.6	12.2	13.7	15.0	16.1	17.2	19.3	21.0

Table II					
Tubing Size	Tubing I.D.	50% Fill	60% Fill	70% Fill	80% Fill
06	.187 (4.7)	.128 (3.3)	.140 (3.6)	.151 (3.8)	.162 (4.1)
09	.281 (7.1)	.193 (4.9)	.211 (5.4)	.229 (5.8)	.244 (6.2)
10	.312 (7.9)	.217 (5.5)	.237 (6.0)	.256 (6.5)	.274 (7.0)
12	.375 (9.5)	.257 (6.5)	.282 (7.2)	.305 (7.7)	.326 (8.3)
14	.437 (11.1)	.302 (7.7)	.331 (8.4)	.357 (9.1)	.382 (9.7)
16	.500 (12.7)	.343 (8.7)	.376 (9.6)	.406 (10.3)	.434 (11.0)
20	.625 (15.9)	.426 (10.8)	.467 (11.9)	.505 (12.8)	.539 (13.7)
24	.750 (19.1)	.513 (13.0)	.562 (14.3)	.607 (15.4)	.649 (16.5)
28	.875 (22.2)	.608 (15.4)	.666 (16.9)	.720 (18.3)	.769 (19.5)
32	1.000 (25.4)	.686 (17.4)	.751 (19.1)	.812 (20.6)	.868 (22.0)
40	1.250 (31.8)	.852 (21.6)	.933 (23.7)	1.008 (25.6)	1.078 (27.4)

Bulk Conduit Length Tolerances	
The following tolerances apply to the lengths of bulk conduit	
Inches	
Length	Tolerance
12 - 144	+ 2.0
145 - 600	+4.0
601 - up	+ 6.0
Centimeters	
Length	Tolerance
31 - 366	+5.0
367 - 1524	+10.2
1525 - up	+15.2

### Catalog Notes

For all parts in this catalog:  
 All parts will be identified with manufacturer's name and part number, space permitting.  
 Metric dimensions appear in parentheses in diagrams and tables, based on 1 inch = 25.4 mm, for reference only.



# Wire Diameter Lookup Tables



WIRE	REFERENCE DIAMETER	REFERENCE WEIGHT (LBS/1000 FT) MAX
M22759/1-22	0.084 (±.004)	7.50
M22759/1-20	0.094 (±.004)	9.50
M22759/1-18	0.105 (±.005)	13.00
M22759/1-16	0.120 (±.005)	16.50
M22759/1-14	0.138 (±.005)	23.00
M22759/1-12	0.157 (±.005)	32.10
M22759/1-10	0.181 (±.007)	47.00
M22759/1-8	0.248 (±.007)	82.00
M22759/1-6	0.293 (±.010)	122.00
M22759/1-4	0.355 (±.015)	180.00
M22759/1-2	0.420 (±.015)	275.00
M22759/1-1	0.470 (±.015)	348.00
M22759/1-01	0.515 (±.020)	429.00
M22759/1-02	0.575 (±.020)	542.00
M22759/1-03	0.640 (±.020)	668.00
M22759/1-04	0.710 (±.020)	835.00

WIRE	REFERENCE DIAMETER	REFERENCE WEIGHT (LBS/1000 FT) MAX
M22759/11-28	0.033 (±.002)	1.36
M22759/11-26	0.038 (±.002)	1.90
M22759/11-24	0.043 (±.002)	2.58
M22759/11-22	0.049 (±.002)	3.72
M22759/11-20	0.058 (±.002)	5.43
M22759/11-18	0.068 (±.002)	8.14
M22759/11-16	0.075 (±.002)	10.00
M22759/11-14	0.090 (±.002)	15.10
M22759/11-12	0.111 (±.002)	24.10
M22759/11-10	0.139 (±.002)	37.80
M22759/11-8	0.202 (±.002)	65.50

WIRE	REFERENCE DIAMETER	REFERENCE WEIGHT (LBS/1000 FT) MAX
M22759/32-30	0.024 (±.002)	0.66
M22759/32-28	0.027 (±.002)	0.91
M22759/32-26	0.032 (±.002)	1.40
M22759/32-24	0.037 (±.002)	2.00
M22759/32-22	0.043 (±.002)	2.80
M22759/32-20	0.050 (±.002)	4.30
M22759/32-18	0.060 (±.002)	6.50
M22759/32-16	0.068 (±.002)	8.30
M22759/32-14	0.085 (±.002)	13.00
M22759/32-12	0.103 (±.002)	19.70

WIRE	REFERENCE DIAMETER	REFERENCE WEIGHT (LBS/1000 FT) MAX
M22759/33-30	0.024 (±.002)	0.660
M22759/33-28	0.027 (±.002)	0.910
M22759/33-26	0.032 (±.002)	1.400
M22759/33-24	0.037 (±.002)	2.000
M22759/33-22	0.043 (±.002)	2.900
M22759/33-20	0.050 (±.002)	4.400

TWISTED PAIR (JACKET & SHIELD)				TWISTED PAIR (NO JACKET OR SHIELD)			
Part Number	Max OD	MAX weight (lbs/1000 ft)	REFERENCE BASIC WIRE	Part Number	Max OD	MAX weight (lbs/1000 ft)	REFERENCE BASIC WIRE
M27500-28RC2S06	0.128	12.947	M22759/11-28	M27500-28RC2U00	0.070	2.774	M22759/11-28
M27500-26RC2S06	0.138	15.107	M22759/11-26	M27500-26RC2U00	0.080	3.876	M22759/11-26
M27500-24RC2S06	0.148	17.553	M22759/11-24	M27500-24RC2U00	0.090	5.263	M22759/11-24
M27500-22RC2S06	0.160	21.149	M22759/11-22	M27500-22RC2U00	0.102	7.589	M22759/11-22
M27500-20RC2S06	0.178	26.543	M22759/11-20	M27500-20RC2U00	0.120	11.077	M22759/11-20
M27500-18RC2S06	0.198	34.188	M22759/11-18	M27500-18RC2U00	0.140	16.606	M22759/11-18
M27500-16RC2S06	0.212	39.464	M22759/11-16	M27500-16RC2U00	0.154	20.400	M22759/11-16
M27500-14RC2S06	0.242	53.044	M22759/11-14	M27500-14RC2U00	0.184	30.804	M22759/11-14
M27500-12RC2S06	0.286	76.061	M22759/11-12	M27500-12RC2U00	0.228	49.164	M22759/11-12
M27500-10RC2S06	0.348	114.607	M22759/11-10	M27500-10RC2U00	0.286	77.112	M22759/11-10
M27500-8RC2S06	0.500	207.438	M22759/11-8	M27500-8RC2U00	0.412	133.620	M22759/11-8
M27500-30SC2S06	0.110	9.614	M22759/33-30	M27500-30SC2U00	0.052	1.346	M22759/33-30
M27500-28SC2S06	0.116	10.759	M22759/33-28	M27500-28SC2U00	0.058	1.856	M22759/33-28
M27500-26SC2S06	0.126	12.817	M22759/33-26	M27500-26SC2U00	0.068	2.856	M22759/33-26
M27500-24SC2S06	0.136	15.100	M22759/33-24	M27500-24SC2U00	0.078	4.080	M22759/33-24
M27500-22SC2S06	0.148	18.206	M22759/33-22	M27500-22SC2U00	0.090	5.916	M22759/33-22
M27500-20SC2S06	0.162	22.748	M22759/33-20	M27500-20SC2U00	0.104	8.976	M22759/33-20

# 120-144 Annular Polymer-Core Convuluted Tubing



## Outstanding mechanical wire protection and lubricity for non-EMI/RFI applications



Standard Black and Natural/Clear Annular Convuluted Tubing

Blue, Yellow, Red, Desert Tan, and Orange Annular Convuluted Tubing

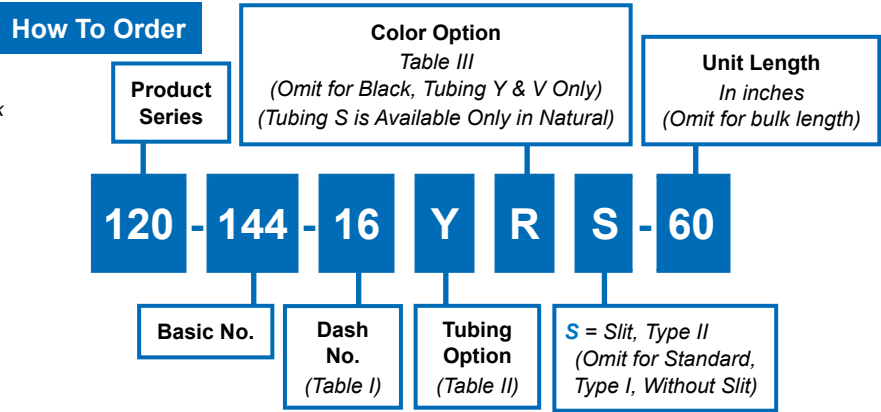

Dash No	A Inside Dia		B Outside Dia
	Min	Max	Max
06	.17 (4.3)	.19 (4.8)	.32 (8.1)
09	.24 (6.1)	.28 (7.1)	.42 (10.7)
12	.33 (8.4)	.37 (9.4)	.52 (13.2)
14	.40 (10.1)	.44 (11.2)	.59 (15.0)
16	.45 (11.4)	.50 (12.7)	.66 (16.8)
20	.57 (14.5)	.62 (15.7)	.77 (20.0)
24	.69 (17.5)	.75 (19.1)	.94 (23.9)
28	.81 (20.6)	.87 (22.1)	1.08 (27.4)
32	.93 (23.6)	1.00 (25.4)	1.20 (30.5)
40	1.18 (30.0)	1.25 (31.8)	1.44 (36.6)
48	1.43 (36.3)	1.50 (38.1)	1.71 (43.4)
52	1.56 (39.6)	1.63 (41.4)	1.85 (47.0)

Y	Kynar/Thermally stabilized
V	PVDF/Not thermally stabilized
S	G-FLEX Siltem/Medium duty

N	Natural/Clear
R	Red (available in Kynar and PVDF only)
Y	Yellow (available in Kynar and PVDF only)
BL	Blue (available in Kynar and PVDF only)
TN	Desert Tan (available in Kynar and PVDF only)
O	Orange (available in Kynar and PVDF only)
Omit for standard black	

Dash No (I.D.)	Max. Length
09 (.281")	2000 ft.
12 (.375")	1500 ft.
16 (.5")	1000 ft.
20 (.625")	700 ft.
24 (.75")	500 ft.
32 (1")	300 ft.
40 (1.25")	200 ft.
48 (1.5")	200 ft.
52 (1.625")	200 ft.

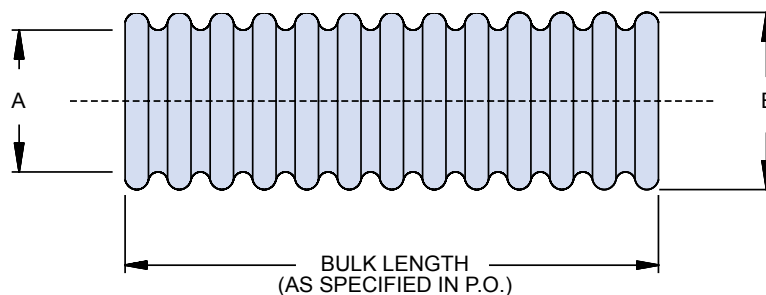

### Packaging

Long-length orders of conduit are subject to the practical limits of shipping box sizes. For example, the maximum length of 1/2 inch (dash 16) conduit that can fit in a standard shipping container is 1000 feet. Unless otherwise specified, Glenair standard practice is to ship optimal lengths of conduit material based on tubing diameter and box size. Consult factory for non-standard length or packaging requirements.

**600-180**  
**Wire Loom Tool For Use With**  
**Split 120-144 Tubing**



**Wire loom tool for split 120-144 conduit wire insertion**



**Wire Loom Tool for Easy Wire Insertion** Glenair Series 120-144 Annular Tubing, in addition to its use in Guardian system assemblies, may also be used without Guardian fittings in open wire loom applications. Adding wires to split conduit is easy with the Wire Loom Tool. Simply gather the desired wires into the tool, and insert into the split conduit. Run the tool through the tubing to complete the process.

Part Number	Max Bundle Dia.
<a href="#">600-180-08</a>	3/8 in (8mm)
<a href="#">600-180-15</a>	5/8 in (15mm)
<a href="#">600-180-20</a>	3/4 in (20mm)
<a href="#">600-180-25</a>	1 in (25 mm)
<a href="#">600-180-32</a>	1 1/4 in (32mm)

**Step 1**

Gather desired wires into the tool



**Step 2**

Insert tool and wires into split conduit



**Step 3**

Run tool through the tubing



**Step 4**

Wire insertion is complete





# 121-190 Annular Polymer-Core Convuluted Tubing with External Braid

## Tubing plus a single EMI/RFI braided shield

B



### How To Order

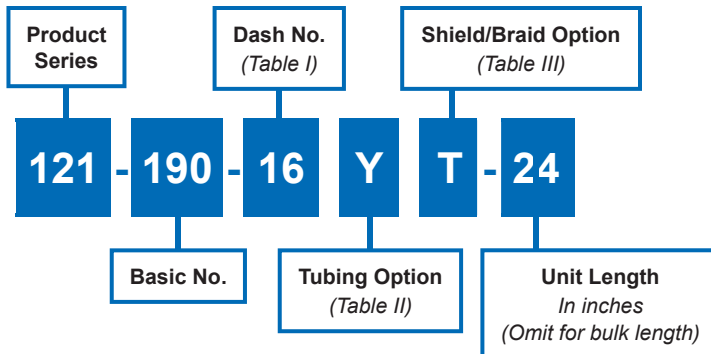

Dash No	A Inside Dia		B Outside Dia
	Min	Max	Max
06	.17 (4.3)	.19 (4.8)	.38 (9.6)
09	.24 (6.1)	.28 (7.1)	.48 (12.2)
12	.33 (8.4)	.37 (9.4)	.58 (14.7)
14	.40 (10.1)	.44 (11.2)	.65 (16.5)
16	.45 (11.4)	.50 (12.7)	.72 (18.3)
20	.57 (14.5)	.62 (15.7)	.83 (21.1)
24	.69 (17.5)	.75 (19.1)	1.00 (25.4)
28	.81 (20.6)	.87 (22.1)	1.14 (28.9)
32	.93 (23.6)	1.00 (25.4)	1.26 (32.0)
40	1.18 (30.0)	1.25 (31.8)	1.50 (38.1)
48	1.43 (36.3)	1.50 (38.1)	1.77 (44.9)
52	1.56 (39.6)	1.63 (41.4)	1.91 (48.5)

Y	Kynar/Thermally stabilized
V	PVDF/Not thermally stabilized
S	G-FLEX Siltem/Medium duty
L	G-FLEX Siltem/High temp, high crush

T	Tin/Copper
C	Stainless Steel
N	Nickel Copper
L	ArmorLite™
D	Dacron
M	Nomex
E	AmberStrand® 100%
F	AmberStrand® 75%/25%

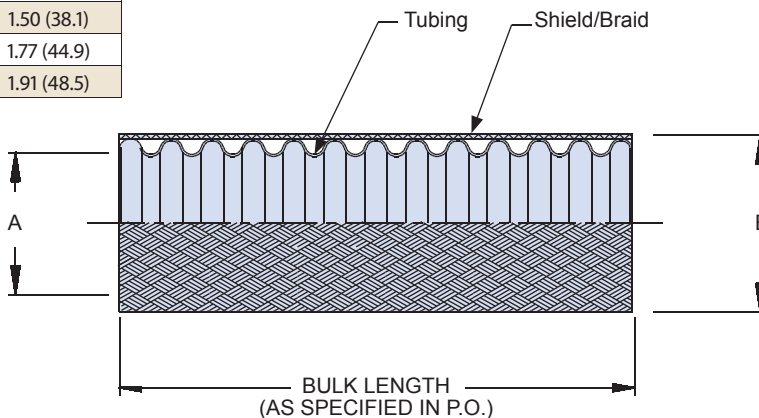

Dash No.	Max Length Per Pkg.
09& 12	200 ft (60m)
16 - 52	100 ft (30m)

### Packaging

Long-length orders of 121-190 braided conduit are subject to carrier weight and box size restrictions. For example, UPS air shipments are currently limited to 50 lbs. per box. Unless otherwise specified, Glenair standard practice is to ship optimal lengths of product based on weight, size, and individual carrier specifications. Consult factory for additional information or to specify packaging requirements.

# 121-191 Annular Polymer-Core Convulsed Tubing with External Braid and Jacket



**Tubing with one EMI/RFI Braided shield plus jacket for use in environmental applications**

### How To Order

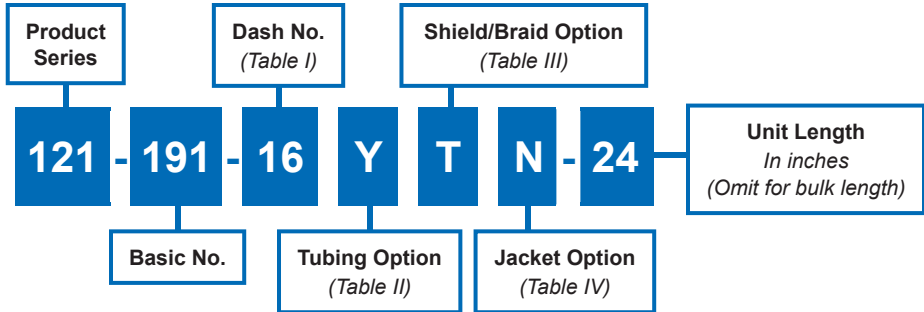

Dash No	A Inside Dia		B Outside Dia
	Min	Max	Max
06	.17 (4.3)	.19 (4.8)	.51 (12.9)
09	.24 (6.1)	.28 (7.1)	.61 (15.5)
12	.33 (8.4)	.37 (9.4)	.71 (18.0)
14	.40 (10.1)	.44 (11.2)	.78 (19.8)
16	.45 (11.4)	.50 (12.7)	.85 (21.6)
20	.57 (14.5)	.62 (15.7)	.96 (24.4)
24	.69 (17.5)	.75 (19.1)	1.13 (28.7)
28	.81 (20.6)	.87 (22.1)	1.27 (32.2)
32	.93 (23.6)	1.00 (25.4)	1.39 (35.3)
40	1.18 (30.0)	1.25 (31.8)	1.63 (41.4)
48	1.43 (36.3)	1.50 (38.1)	1.90 (48.3)
52	1.56 (39.6)	1.63 (41.4)	2.04 (51.8)

Y	Kynar/Thermally stabilized
V	PVDF/Not thermally stabilized
S	G-FLEX Siltem/Medium duty
L	G-FLEX Siltem/High temp, high crush

N	Neoprene
H	Hypalon
E	EPDM
V	Viton
B	Duralectric, black
G	Bluejacket, Gray
TN	Duralectric, Desert Tan

T	Tin/Copper
C	Stainless Steel
N	Nickel Copper
L	ArmorLite™
D	Dacron
M	Nomex
E	AmberStrand® 100%
F	AmberStrand® 75%/25%
-	No braid

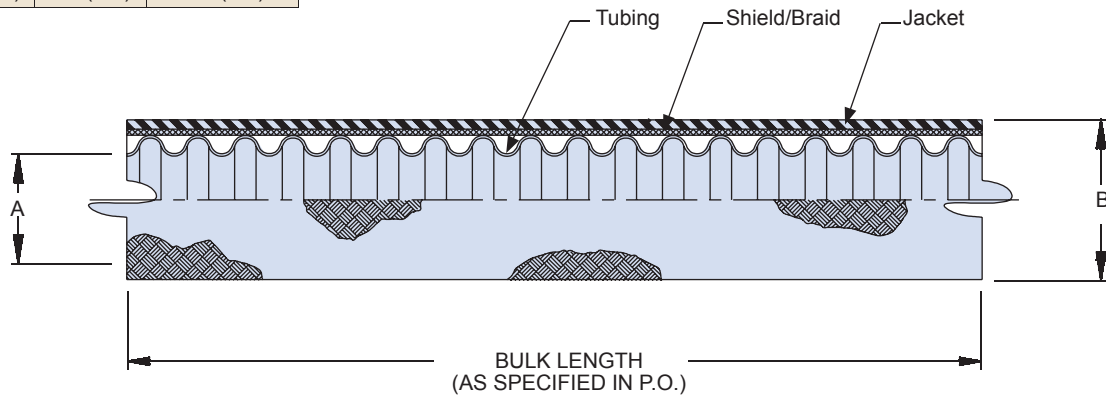

Dash No.	Max Length Per Pkg.
09& 12	200 ft (60m)
16 - 52	100 ft (30m)

### Packaging

121-191 braided and jacketed conduit is typically supplied in 50 foot lengths. Longer lengths are available—consult factory for additional information. Unless otherwise specified, Glenair packages optimal lengths of product based on weight, size, and commercial carrier specifications. If necessary, consult factory for additional information on package weight restrictions.



# 121-192 Annular Polymer-Core Convuluted Tubing with Double External Braid

**Tubing plus a double layer of high dB EMI/RFI shielding**

**B**

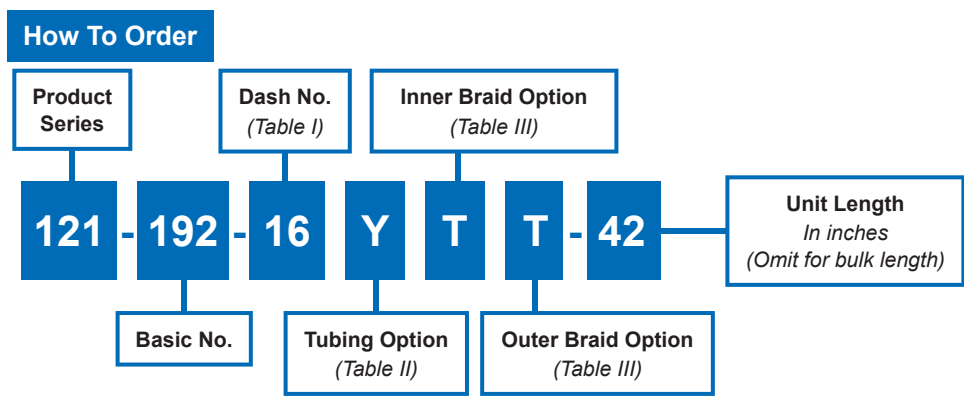

Dash No	A Inside Dia		B Outside Dia
	Min	Max	Max
06	.17 (4.3)	.19 (4.8)	.44 (11.1)
09	.24 (6.1)	.28 (7.1)	.54 (13.7)
12	.33 (8.4)	.37 (9.4)	.64 (16.2)
14	.40 (10.1)	.44 (11.2)	.71 (18.0)
16	.45 (11.4)	.50 (12.7)	.78 (19.8)
20	.57 (14.5)	.62 (15.7)	.89 (22.6)
24	.69 (17.5)	.75 (19.1)	1.06 (26.9)
28	.81 (20.6)	.87 (22.1)	1.20 (30.5)
32	.93 (23.6)	1.00 (25.4)	1.32 (33.5)
40	1.18 (30.0)	1.25 (31.8)	1.56 (39.6)
48	1.43 (36.3)	1.50 (38.1)	1.83 (46.5)
52	1.56 (39.6)	1.63 (41.4)	1.97 (50.0)

Y	Kynar/Thermally stabilized
V	PVDF/Not thermally stabilized
S	G-FLEX Siltem/Medium duty
L	G-FLEX Siltem/High temp, high crush

T	Tin/Copper
C	Stainless Steel
N	Nickel Copper
L	ArmorLite™
D	Dacron
M	Nomex
E	AmberStrand® 100%
F	AmberStrand® 75%/25%

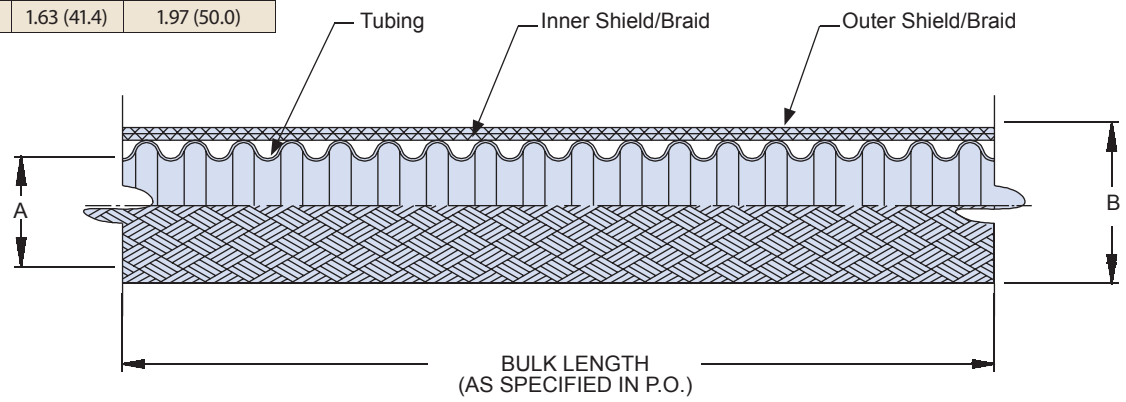

Dash No.	Max Length Per Pkg.
09& 12	200 ft (60m)
16 - 52	100 ft (30m)

**Packaging**  
 Long-length orders of 121-192 braided conduit are subject to carrier weight and box size restrictions. For example, UPS air shipments are currently limited to 50 lbs. per box. Unless otherwise specified, Glenair standard practice is to ship optimal lengths of product based on weight, size, and individual carrier specifications. Consult factory for additional information or to specify packaging requirements.

121-193

Annular Polymer-Core Convulsed Tubing  
with Double External Braid and Jacket



Series 72  
Annular Tubing

B

For environmental EMI/RFI applications with high dB shielding requirements

How To Order

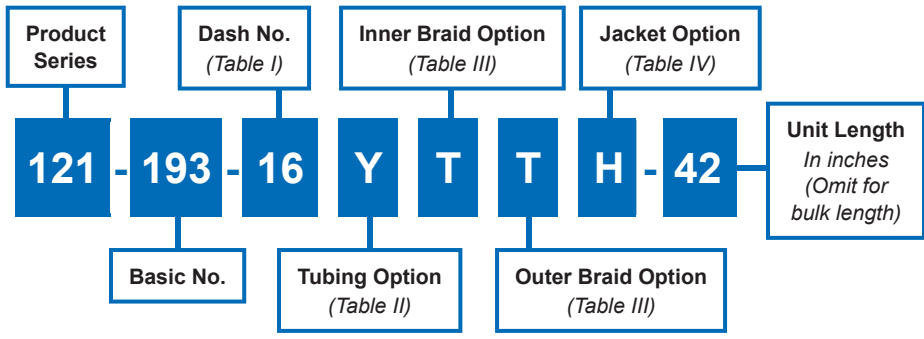

Dash No	A Inside Dia		B Outside Dia
	Min	Max	Max
06	.17 (4.3)	.19 (4.8)	.57 (14.5)
09	.24 (6.1)	.28 (7.1)	.67 (17.0)
12	.33 (8.4)	.37 (9.4)	.77 (19.5)
14	.40 (10.1)	.44 (11.2)	.84 (21.3)
16	.45 (11.4)	.50 (12.7)	.91 (23.1)
20	.57 (14.5)	.62 (15.7)	1.02 (25.9)
24	.69 (17.5)	.75 (19.1)	1.19 (30.2)
28	.81 (20.6)	.87 (22.1)	1.33 (33.8)
32	.93 (23.6)	1.00 (25.4)	1.45 (36.8)
40	1.18 (30.0)	1.25 (31.8)	1.69 (42.9)
48	1.43 (36.3)	1.50 (38.1)	1.96 (49.8)
52	1.56 (39.6)	1.63 (41.4)	2.10 (53.3)

Y	Kynar/Thermally stabilized
V	PVDF/Not thermally stabilized
S	G-FLEX Siltem/Medium duty
L	G-FLEX Siltem/High temp, high crush

T	Tin/Copper
C	Stainless Steel
N	Nickel Copper
L	ArmorLite™
D	Dacron
M	Nomex
E	AmberStrand® 100%
F	AmberStrand® 75%/25%

N	Neoprene
H	Hypalon
E	EPDM
V	Viton
B	Duraelectric, black
G	Bluejacket, Gray
TN	Duraelectric, Desert Tan

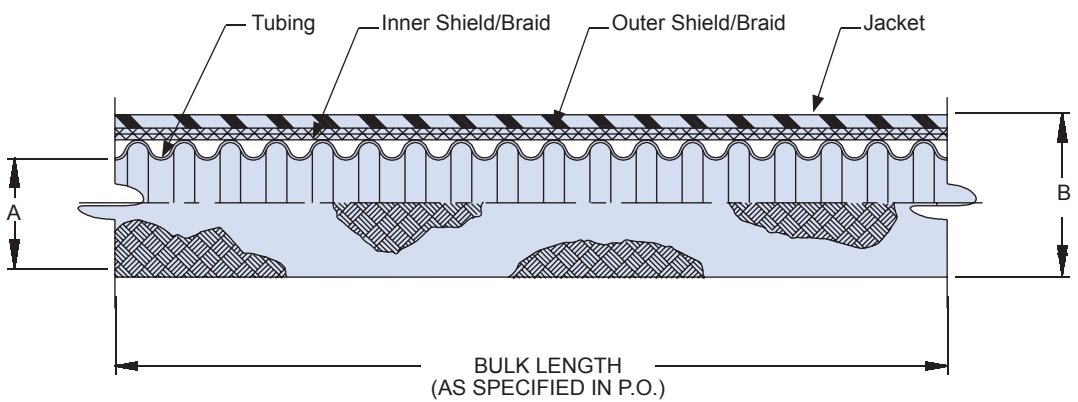

Dash No.	Max Length Per Pkg.
09& 12	200 ft (60m)
16 - 52	100 ft (30m)

Packaging

121-193 braided and jacketed conduit is typically supplied in 50 foot lengths. Longer lengths are available—consult factory for additional information. Unless otherwise specified, Glenair packages optimal lengths of product based on weight, size, and commercial carrier specifications. If necessary, consult factory for additional information on package weight restrictions.

**Metal Guardian System universal connector and adapter fitting**

**How To Order**



Self-Locking

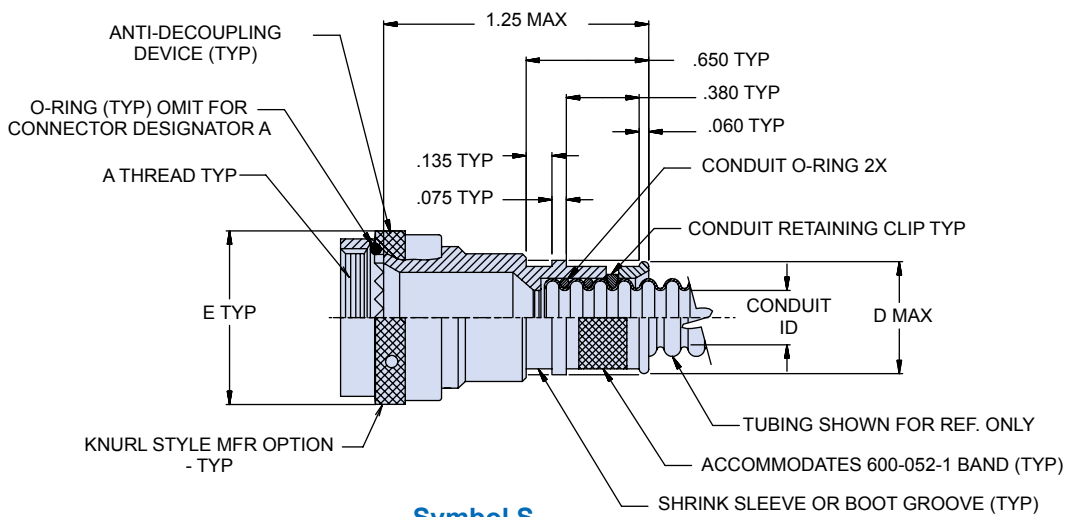
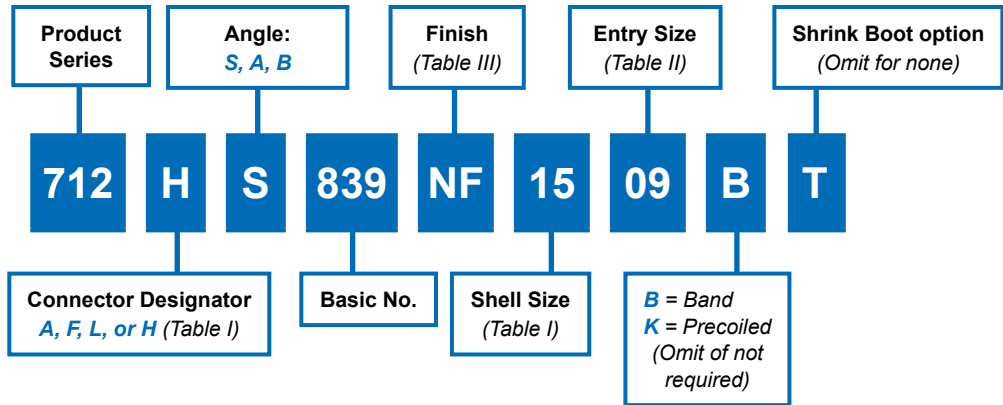

**Symbol S**  
Straight

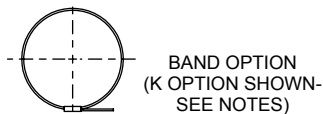

**Material and Finish**

Adapters, elbows, coupling nut: Aluminum Alloy or Stainless Steel per Table III  
O-ring: Silicone/NA  
Retaining clip: High grade engineering thermoplastic/NA  
Anti-decoupling device: Corrosion resistant material

**Tools and Assembly notes**

Conduit retaining clip and conduit O-ring to be supplied unassembled  
For effective grounding, connector with conductive Finish should be used  
Glennair assembly procedure AP74-010 is recommended for adapter to conduit termination  
Glennair 600 Series backshell assembly tools are recommended for assembly and installation  
Interfacial O-ring not supplied with Connector Designator "A"



**712-839**  
**Metal Self-Locking EMI/RFI Environmental**  
**Connector Adapter**  
**for Series 72 Annular Convolute Tubing**



Series 72  
Guardian

**Standard Profile**  
**Symbol B**  
**45°**

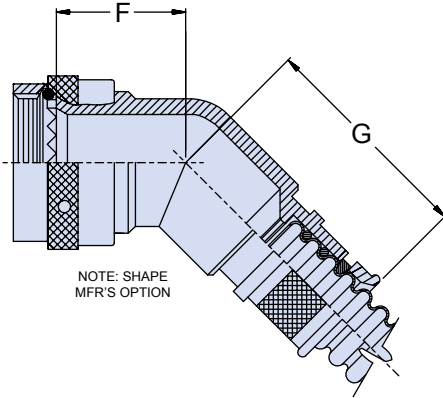

Table I					
Shell Size		F	G	H	J
A,F,L	H	Max	Max	Max	Max
08	09	1.01 (25.7)	1.16 (29.5)	1.150 (29.2)	1.417 (36.0)
10	11	1.03 (26.2)	1.19 (30.2)	1.177 (29.9)	1.480 (37.6)
12	13	1.06 (26.9)	1.21 (30.7)	1.302 (33.1)	1.553 (39.4)
14	15	1.08 (27.4)	1.24 (31.5)	1.367 (34.7)	1.614 (41.0)
16	17	1.11 (28.2)	1.26 (32.0)	1.395 (35.4)	1.678 (42.6)
18	19	1.12 (28.4)	1.27 (32.3)	1.455 (37.0)	1.773 (45.0)
20	21	1.15 (29.2)	1.30 (33.0)	1.518 (38.6)	1.796 (45.6)
22	23	1.17 (29.7)	1.33 (33.8)	1.612 (40.9)	1.859 (47.2)
24	25	1.20 (30.5)	1.35 (34.3)	1.645 (41.8)	1.919 (48.7)

Table II				
Entry Code	D Max	Conduit ID		T Shrink Boot
		Min	Max	
06	.53 (13.5)	.16 (4.1)	.19 (4.8)	770-001S103
09	.63 (16.0)	.24 (6.1)	.28 (7.1)	770-001S103
12	.73 (18.5)	.33 (8.4)	.37 (9.4)	770-001S104
16	.86 (21.8)	.45 (11.4)	.50 (12.7)	770-001S104
20	.98 (24.9)	.57 (14.5)	.62 (15.8)	770-001S105
24	1.15 (29.2)	.69 (17.5)	.75 (19.1)	770-001S106
28	1.27 (32.3)	.81 (20.6)	.87 (22.2)	770-001S107
32	1.40 (35.6)	.93 (23.6)	1.00 (25.4)	770-001S107
40	1.62 (41.1)	1.18 (30.0)	1.25 (31.8)	770-001S107

**Standard Profile**  
**Symbol A**  
**90°**

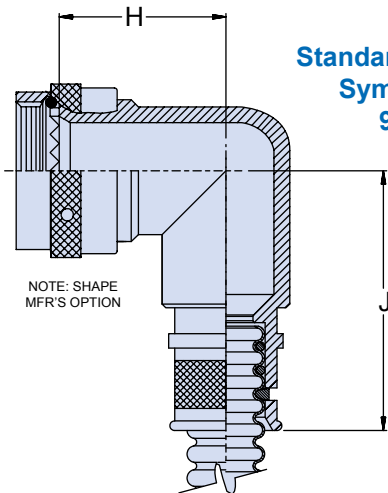
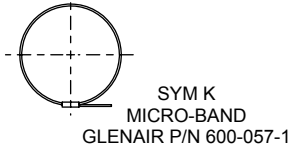
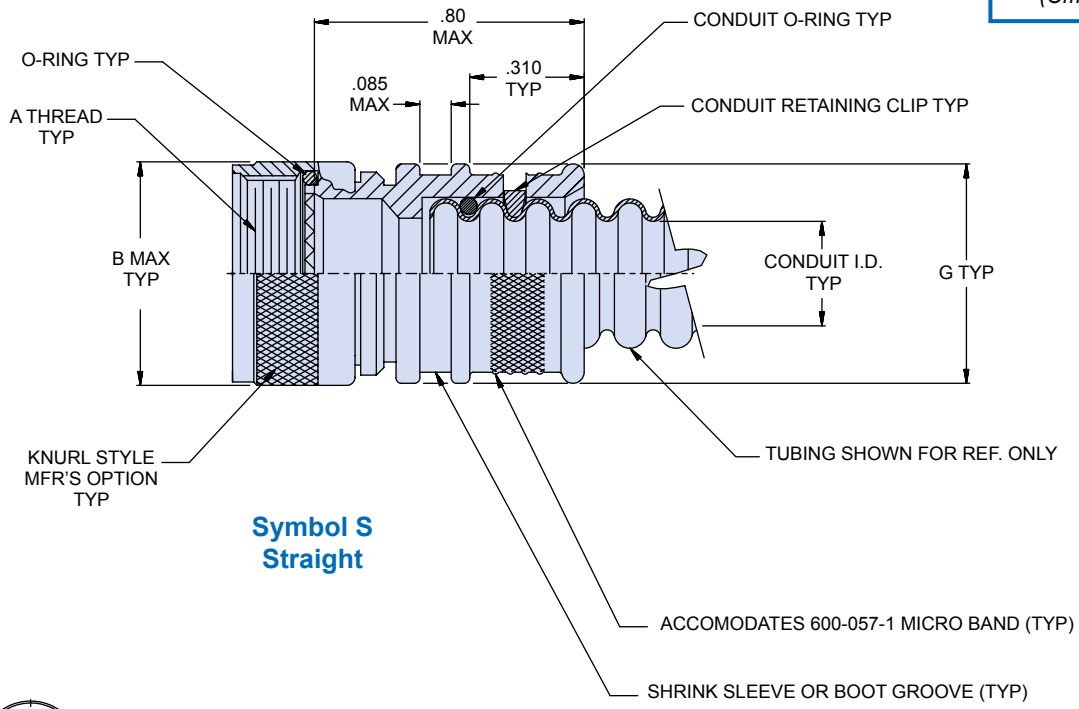
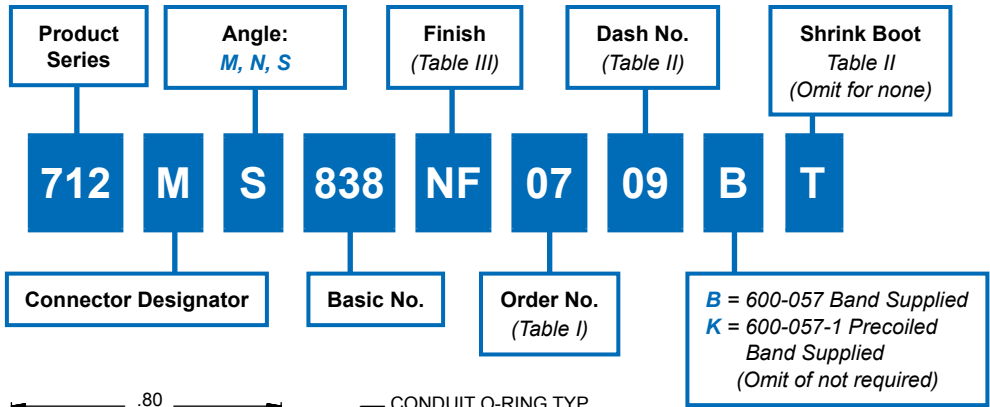

Table III		
Sym	Material	Finish Description
M	Aluminum	Electroless Nickel
MT		Nickel-PTFE
NF		Cad/Olive Drab over Electroless Nickel
ZN		Zinc Nickel/Olive Drab over Electroless Nickel
ZNU		Zinc Nickel/Black over Electroless Nickel
Z1	Stainless Steel	Passivate

**Metal Guardian System Mighty Mouse connector adapter fitting**

**How To Order**



**Material and Finish**

Adapters, coupling nut: See Table III  
 O-ring: Silicone/NA  
 Retaining clip: High grade engineering thermoplastic/NA  
 Band: SST/Passivate

**Tools and Assembly notes**

Conduit retaining clip and conduit O-ring to be supplied unassembled  
 For effective grounding, connector with conductive Finish should be used  
 Glennair assembly procedure AP74-010 is recommended for adapter to conduit termination

**712M\*838**  
**Metal EMI/RFI Environmental**  
**Adapter for Mighty Mouse Connectors**  
**for Series 72 Annular Convolute Tubing**



Series 72  
Guardian

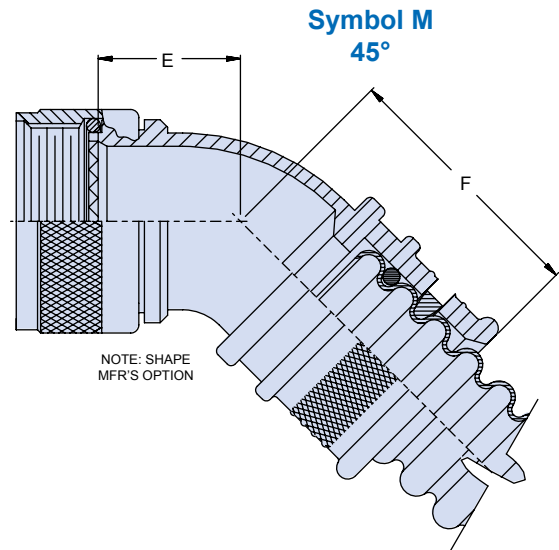
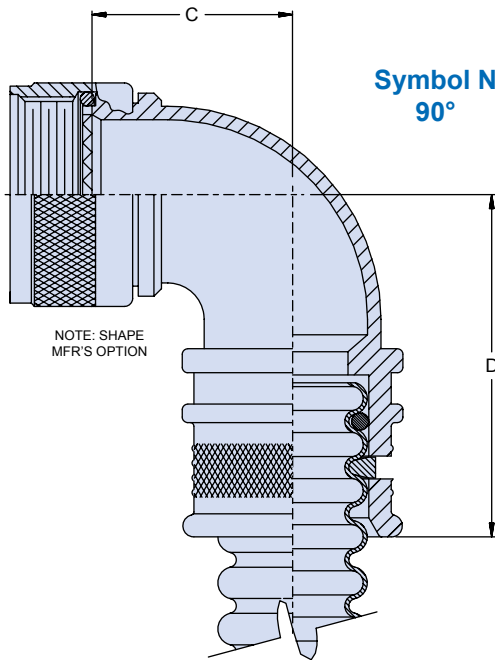

Table I

Order No.	Shell Size Ref		A Thread Class 2B	B Max
	800/801 803/804	805		
5	5	N/A	1/4-32 UNEF	0.470 (11.9)
6	6	N/A	5/16-32 UNEF	0.530 (13.5)
11	N/A	8	3/8-32 UNEF	0.570 (14.5)
7	7	9	7/16-28 UNEF	0.637 (16.2)
8	8	10	1/2-28 UNEF	0.700 (17.8)
9	9	11	9/16-24 UNEF	0.758 (19.3)
10	10	12	5/8-24 UNEF	0.819 (20.8)
12	12/13	N/A	11/16-24 UNEF	0.896 (22.8)
13	N/A	15	3/4-20 UNEF	0.930 (23.6)
14	14/15/16/17	18/19	15/16-20 UNEF	1.137 (28.9)
17	21	23	1 3/16-18 UNEF	1.387 (35.2)

Table III

Sym	Material	Finish Description
M	Aluminum	Electroless Nickel
MT		Nickel-PTFE
NF		Cad/Olive Drab over Electroless Nickel
ZN		Zinc Nickel/Olive Drab over Electroless Nickel
ZNU		Zinc Nickel/Black over Electroless Nickel
Z1	Stainless Steel	Passivate

Table II

Dash No.	C Max	D Max	E Max	F Max	G Max	Conduit I.D.		Shrink Boot
						Min	Max	
06	0.73 (18.5)	1.02 (25.9)	.61 (15.5)	.90 (22.9)	.53 (13.5)	.16 (4.1)	.19 (4.8)	770-001S103
09	0.79 (20.1)	1.08 (27.4)	.64 (16.3)	.92 (23.4)	.63 (16.0)	.24 (6.1)	.28 (7.1)	770-001S103
12	0.85 (21.6)	1.14 (29.0)	.66 (16.8)	.95 (24.1)	.73 (18.5)	.33 (8.4)	.37 (9.4)	770-001S104
16	0.92 (23.4)	1.20 (30.5)	.71 (18.0)	1.00 (25.4)	.86 (21.8)	.45 (11.4)	.50 (12.7)	770-001S104
20	0.98 (24.9)	1.27 (32.3)	.74 (18.8)	1.03 (26.2)	.98 (24.9)	.57 (14.5)	.62 (15.7)	770-001S105
24	1.04 (26.4)	1.33 (33.8)	.79 (20.1)	1.08 (27.4)	1.15 (29.2)	.69 (17.5)	.75 (19.1)	770-001S106
28	1.10 (27.9)	1.39 (35.3)	.82 (20.8)	1.10 (27.9)	1.27 (32.3)	.81 (20.6)	.87 (22.1)	770-001S107
32	1.17 (29.7)	1.45 (36.8)	.84 (21.3)	1.13 (28.7)	1.40 (35.6)	.93 (23.6)	1.00 (25.4)	770-001S107

**Metal Guardian System bulkhead feed-thru fitting**

**How To Order**

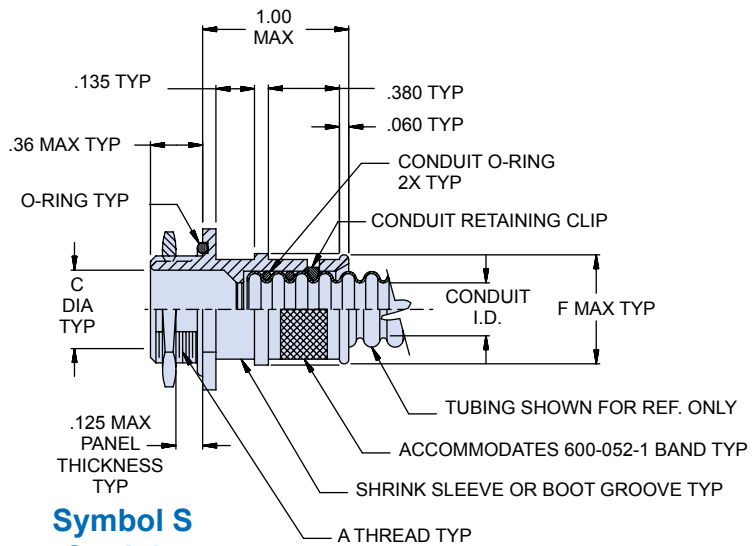
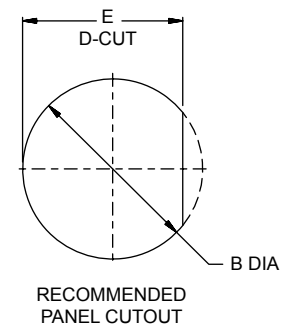
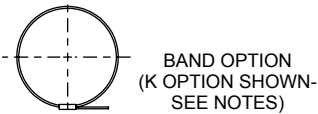
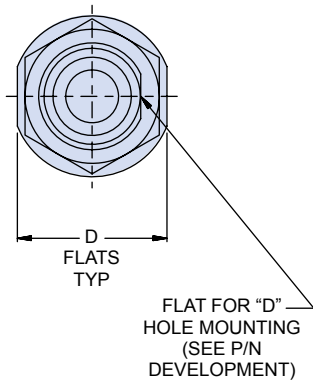
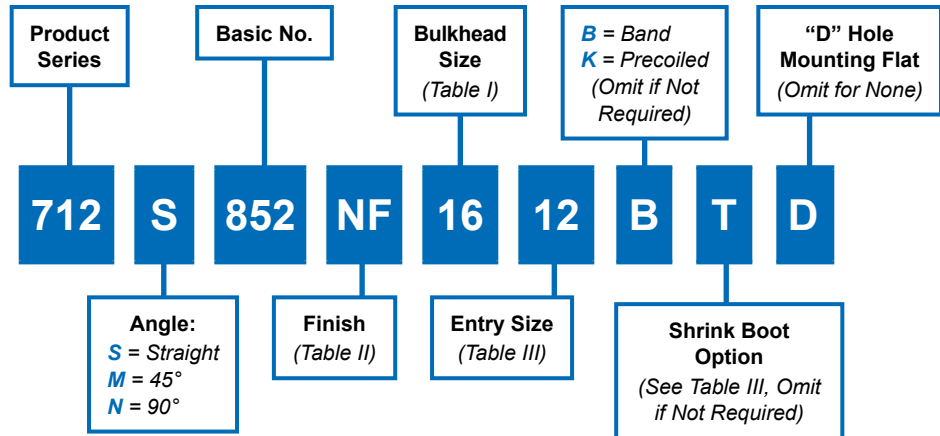

**Symbol S**  
**Straight**

**Material and Finish**

Adapters, elbows: See Table II  
O-rings: Silicone/NA  
Retaining Clip: High Grade Engineering Thermoplastic/NA

**Tools, Accessories and Assembly notes**

Tubing shown for Reference only.  
Glenair 600 Series backshell assembly tools are recommended for assembly and installation.  
Glenair Assembly procedure AP74-010 is recommended for adapter to conduit termination.  
Conduit retaining clip and O-ring to be supplied unassembled.

712-852

**Metal EMI/RFI Environmental Bulkhead Feed-Thru Fitting  
for Series 72 Annular Convolute Tubing**



Series 72  
Guardian

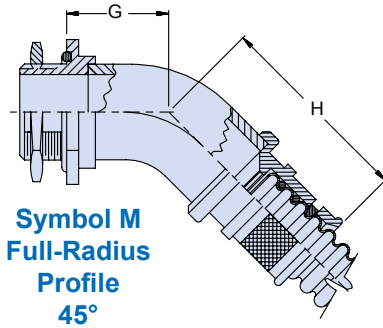

Table I						
Bulkhead Size	A Thread Class 2A	B $+0.015$ $-0.000$	C Dia	D Flats	E $+0.010$ $-0.000$	Max Entry Size
06	3/8-32 UNEF	0.380 (9.7)	0.188 (4.8)	0.625 (15.9)	0.323 (8.2)	09
08	7/16-28 UNEF	0.443 (11.3)	0.250 (6.4)	0.688 (17.5)	0.385 (9.8)	12
09	1/2-20 UNF	0.505 (12.8)	0.281 (7.1)	0.750 (19.1)	0.448 (11.4)	12
10	1/2-20 UNF	0.505 (12.8)	0.312 (7.9)	0.750 (19.1)	0.448 (11.4)	12
12	9/16-24 UNEF	0.568 (14.4)	0.375 (9.5)	0.812 (20.6)	0.510 (13.0)	16
14	5/8-24 UNEF	0.63 (16.0)	0.438 (11.1)	0.875 (22.2)	0.573 (14.6)	16
16	11/16-24 UNEF	0.693 (17.6)	0.500 (12.7)	0.937 (23.8)	0.635 (16.1)	20
20	13/16-20 UNEF	0.818 (20.8)	0.625 (15.9)	1.062 (27.0)	0.760 (19.3)	20
24	15/16-20 UNEF	0.943 (24.0)	0.750 (19.1)	1.250 (31.8)	0.885 (22.5)	24
28	1 1/16-18 UNEF	1.068 (27.1)	0.875 (22.2)	1.375 (34.9)	1.010 (25.7)	32
32	1 3/16-18 UNEF	1.193 (30.3)	1.000 (25.4)	1.562 (39.7)	1.135 (28.8)	32
40	1 7/16-18 UNEF	1.443 (36.7)	1.250 (31.8)	1.875 (47.6)	1.385 (35.2)	40

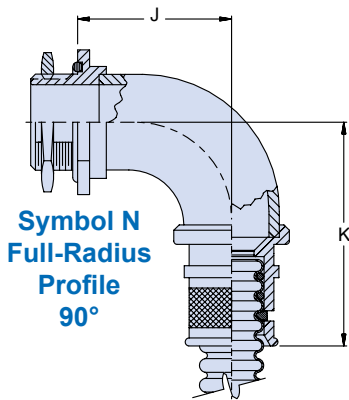

Table II		
Sym	Material	Finish Description
M	Aluminum	Electroless Nickel
MT		Nickel-PTFE
NF		Cad/Olive Drab over Electroless Nickel
ZN		Zinc Nickel/Olive Drab over Electroless Nickel
ZNU		Zinc Nickel/Black over Electroless Nickel
ZI	Stainless Steel	Passivate

Table III								
Entry Size	F Max	Conduit I.D.		G Max	H Max	J Max	K Max	Shrink Boot Ref
		Min	Max					
06	0.53 (13.5)	0.16 (4.1)	0.19 (4.8)	0.50 (12.7)	1.02 (25.9)	0.68 (17.3)	1.20 (30.5)	770-001S103
09	0.63 (16.0)	0.24 (6.1)	0.28 (7.1)	0.53 (13.5)	1.04 (26.4)	0.75 (19.1)	1.26 (32.0)	770-001S103
12	0.73 (18.5)	0.33 (8.4)	0.37 (9.4)	0.53 (13.5)	1.04 (26.4)	0.75 (19.1)	1.26 (32.0)	770-001S104
16	0.86 (21.8)	0.45 (11.4)	0.50 (12.7)	0.55 (14.0)	1.07 (27.2)	0.81 (20.6)	1.33 (33.8)	770-001S104
20	0.98 (24.9)	0.57 (14.5)	0.62 (15.7)	0.61 (15.5)	1.12 (28.4)	0.93 (23.6)	1.45 (36.8)	770-001S105
24	1.15 (29.2)	0.69 (17.5)	0.75 (19.1)	0.63 (16.0)	1.15 (29.2)	1.00 (25.4)	1.51 (38.4)	770-001S106
28	1.27 (32.3)	0.81 (20.6)	0.87 (22.1)	0.68 (17.3)	1.20 (30.5)	1.12 (28.4)	1.64 (41.7)	770-001S107
32	1.40 (35.6)	0.93 (23.6)	1.00 (25.4)	0.71 (18.0)	1.22 (31.0)	1.18 (30.0)	1.70 (43.2)	770-001S107
40	1.62 (41.1)	1.18 (30.0)	1.25 (31.8)	0.76 (19.3)	1.28 (32.5)	1.31 (33.3)	1.83 (46.5)	770-001S107

**Composite Guardian System connector adapter**



Self-Locking

**How To Order**

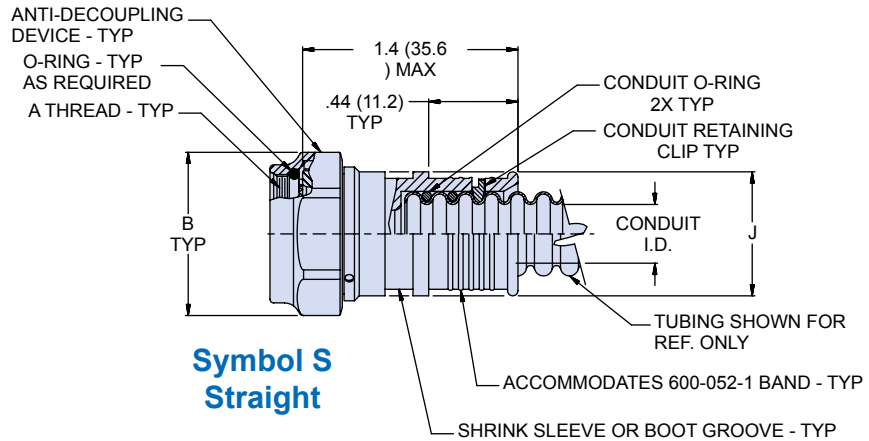
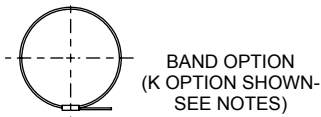
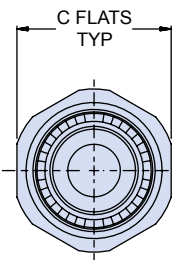
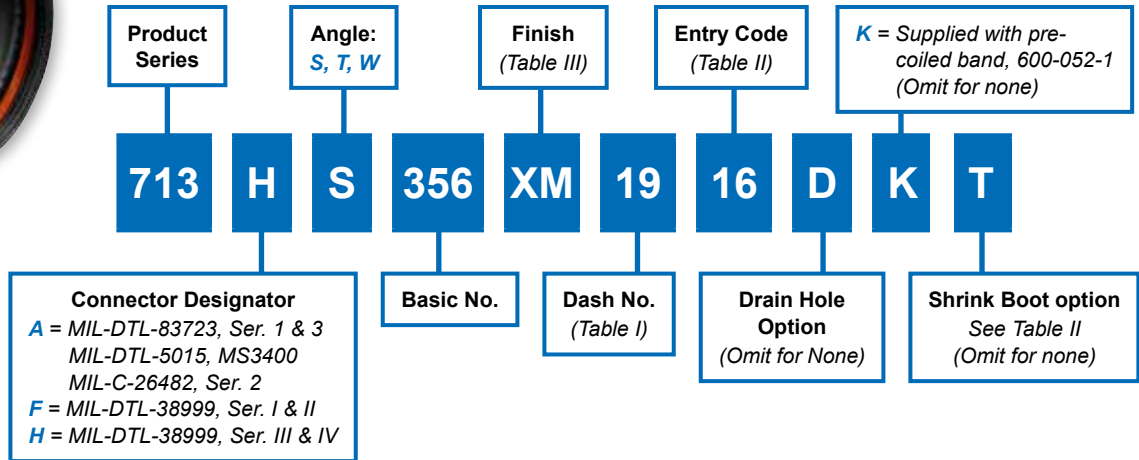

**Material and Finish**

Elbow, adapter: High grade engineering thermoplastic/See Table III  
 Coupling nut, conduit retaining clip: High grade engineering thermoplastic/no plating  
 Anti-decoupling device: Corrosion resistant material/NA  
 O-rings: Silicone/NA

**Tools and Assembly notes**

Conduit retaining clip and conduit O-ring to be supplied unassembled  
 For effective grounding, connector with conductive Finish should be used  
 Glennair assembly procedure AP74-010 is recommended for adapter to conduit termination  
 Glennair 600 Series backshell assembly tools are recommended for assembly and installation

# 713-356 Composite Self-Locking EMI/RFI Environmental Connector Adapter for Series 72 Annular Convolute Tubing



Series 72  
Guardian

Table I

Connector Designator A			Connector Designator F			Connector Designator H			B Dia Max	C Flats	
Dash No.	Shell Size Ref	A Thread Class 2B	Dash No.	Shell Size Ref	A Thread Class 2B	Dash No.	Shell Size Ref	A Thread Iso Metric		Max	Min
08	08	1/2-20 UNF	08	09	7/16-28 UNEF	09	A	M12 X 1.0-6H	.83 (21.1)	.750 (19.1)	.736 (18.7)
10	10	5/8-24 UNEF	10	11	9/16-24 UNEF	11	B	M15 X 1.0-6H	.96 (24.4)	.875 (22.2)	.860 (21.8)
12	12	3/4-20 UNEF	12	13	11/16-24 UNEF	13	C	M18 X 1.0-6H	1.09 (27.7)	1.000 (25.4)	.980 (24.9)
14	14	7/8-20 UNEF	14	15	13/16-20 UNEF	15	D	M22 X 1.0-6H	1.22 (31.0)	1.125 (28.6)	1.100 (27.9)
16	16	1-20 UNEF	16	17	15/16-20 UNEF	17	E	M25 X 1.0-6H	1.35 (34.3)	1.250 (31.8)	1.224 (31.1)
18	18	1 1/16-18 UNEF	18	19	1 1/16-18 UNEF	19	F	M28 X 1.0-6H	1.48 (37.6)	1.375 (34.9)	1.348 (34.2)
20	20	1 3/16-18 UNEF	20	21	1 3/16-18 UNEF	21	G	M31 X 1.0-6H	1.62 (41.1)	1.500 (38.1)	1.469 (37.3)
22	22	1 5/16-18 UNEF	22	23	1 5/16-18 UNEF	23	H	M34 X 1.0-6H	1.75 (44.5)	1.625 (41.3)	1.581 (40.2)
24	24	1 7/16-18 UNEF	24	25	1 7/16-18 UNEF	25	J	M37 X 1.0-6H	1.89 (48.0)	1.750 (44.5)	1.690 (42.9)

Table I (cont.)

Conn Desig		D ±.06 (1.5)	E ±.09 (2.3)	F ±.09 (2.3)	G ±.06 (1.5)	H ±.09 (2.3)
A,F	H					
08	09	.69 (17.5)	.88 (22.4)	1.19 (30.2)	.72 (18.3)	1.00 (25.4)
10	11	.75 (19.1)	1.00 (25.4)	1.25 (31.8)	.75 (19.1)	1.06 (26.9)
12	13	.81 (20.6)	1.13 (28.7)	1.31 (33.3)	.75 (19.1)	1.13 (28.7)
14	15	.88 (22.4)	1.31 (33.3)	1.38 (35.1)	.76 (19.3)	1.16 (29.5)
16	17	.94 (23.9)	1.38 (35.1)	1.44 (36.6)	.78 (19.8)	1.18 (30.0)
18	19	.97 (24.6)	1.44 (36.6)	1.47 (37.3)	.79 (20.1)	1.19 (30.2)
20	21	1.06 (26.9)	1.63 (41.4)	1.56 (39.6)	.82 (20.8)	1.22 (31.0)
22	23	1.13 (28.7)	1.75 (44.5)	1.63 (41.4)	.86 (21.8)	1.26 (32.0)
24	25	1.19 (30.2)	1.88 (47.8)	1.69 (42.9)	.89 (22.6)	1.29 (32.8)

Table II

Entry Code	J Max	Conduit I.D.		Shrink Boot
		Min	Max	
06	.53 (13.5)	.16 (4.1)	.19 (4.8)	770-001S103
09	.63 (16.0)	.24 (6.1)	.28 (7.1)	770-001S103
12	.73 (18.5)	.33 (8.4)	.37 (9.4)	770-001S104
16	.86 (21.8)	.45 (11.4)	.50 (12.7)	770-001S104
20	.98 (24.9)	.57 (14.5)	.62 (15.8)	770-001S105
24	1.15 (29.2)	.69 (17.5)	.75 (19.1)	770-001S106
28	1.27 (32.3)	.81 (20.6)	.87 (22.2)	770-001S107
32	1.40 (35.6)	.93 (23.6)	1.00 (25.4)	770-001S107

Table III

Symbol	Finish Description
XM	Electroless Nickel
XW	Cad/Olive Drab over Electroless Nickel
XB	Black color/Unplated

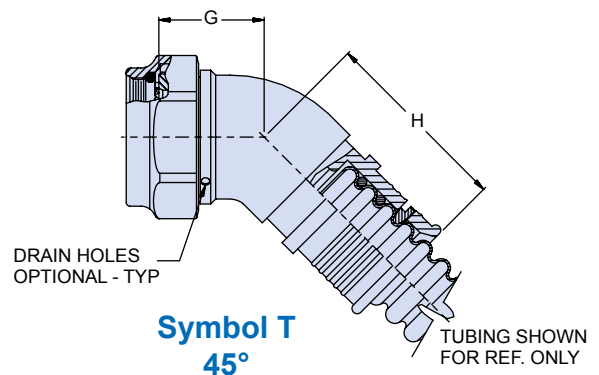
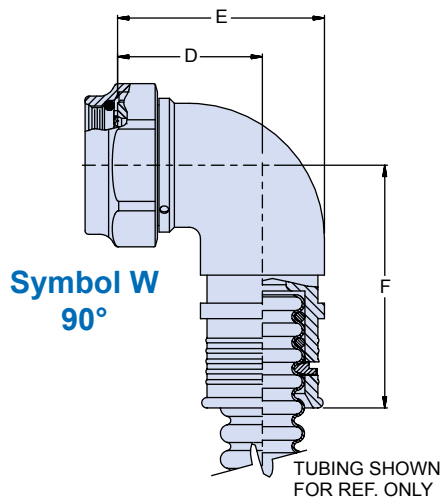

**Composite Guardian System bulkhead and junction box feed-thru fitting**

**How To Order**

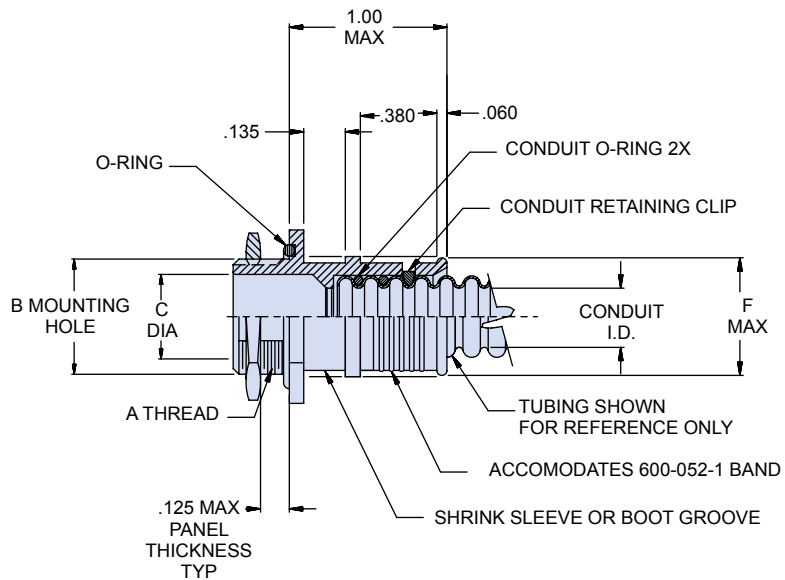
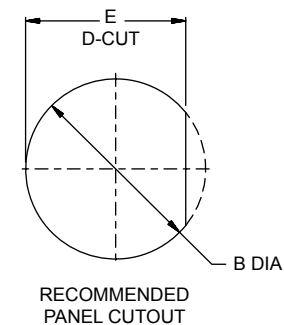
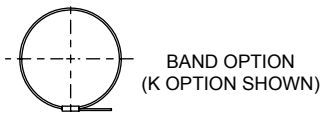
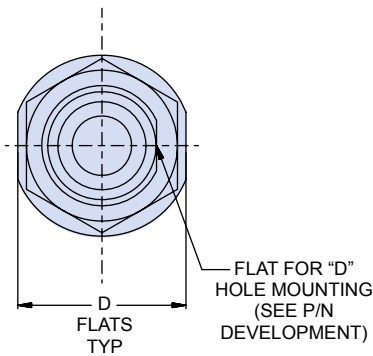
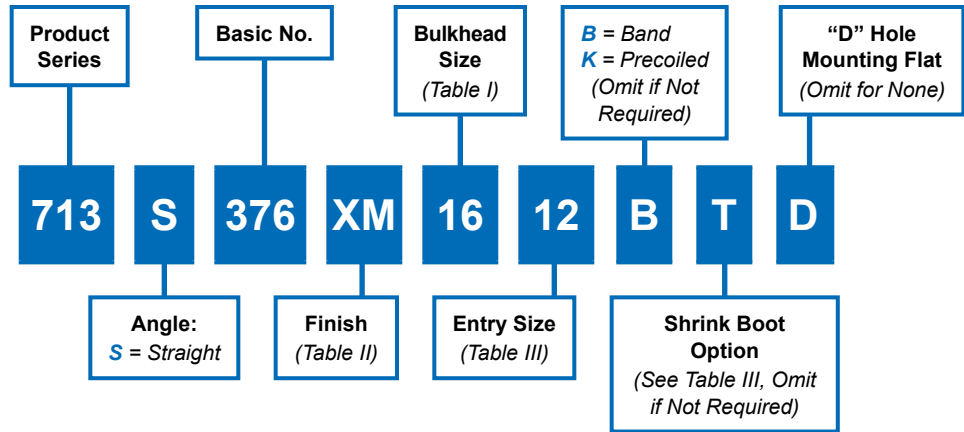

**Material and Finish**

Adapter and Jam nut: High grade engineering thermoplastic/See Table II  
 O-rings: Silicone/NA  
 Retaining clip: High grade engineering thermoplastic/no plating

**Tools and Assembly notes**

Conduit retaining clip and conduit O-ring to be supplied unassembled  
 For effective grounding, connector with conductive Finish should be used  
 Glennair assembly procedure AP74-010 is recommended for adapter to conduit termination  
 Glennair 600 Series backshell assembly tools are recommended for assembly and installation



**Composite Guardian Bulkhead  
and Junction Box Feed-Thru Fitting  
for Series 72 Annular Convuluted Tubing**



Table I

Bulkhead Size	A Thread Class 2A	B $+.015$ $-.000$	C Dia	D Flats	E $+.010$ $-.000$	Max Entry Size
06	7/16-28 UNEF	0.443 (11.3)	0.188 (4.8)	0.688 (17.5)	0.385 (9.8)	09
08	1/2-20 UNF	0.505 (12.8)	0.250 (6.4)	0.750 (19.1)	0.448 (11.4)	12
09	9/16-24 UNEF	0.568 (14.4)	0.281 (7.1)	0.812 (20.6)	0.510 (13.0)	12
10	9/16-24 UNEF	0.568 (14.4)	0.312 (7.9)	0.812 (20.6)	0.510 (13.0)	12
12	5/8-24 UNEF	0.630 (16.0)	0.375 (9.5)	0.875 (22.2)	0.573 (14.6)	16
14	11/16-24 UNEF	0.693 (17.6)	0.438 (11.1)	0.938 (23.8)	0.635 (16.2)	16
16	3/4-20 UNEF	0.755 (19.2)	0.500 (12.7)	1.000 (25.4)	0.698 (17.7)	20
20	7/8-20 UNEF	0.880 (22.4)	0.625 (15.9)	1.125 (28.6)	0.822 (20.9)	20
24	1-20 UNEF	1.005 (25.5)	0.750 (19.1)	1.250 (31.8)	0.948 (24.1)	24
28	1 3/16-8 UNEF	1.193 (30.3)	0.875 (22.2)	1.438 (36.5)	1.135 (28.8)	32
32	1 5/16-18 UNEF	1.318 (33.5)	1.000 (25.4)	1.562 (39.7)	1.260 (32.0)	32
40	1 1/2-18 UNEF	1.505 (38.2)	1.250 (31.8)	1.812 (46.0)	1.448 (36.8)	40

Table III

Symbol	Finish Description
XM	Electroless Nickel
XW	Cad/Olive Drab over Electroless Nickel
XB	Black color/Unplated

Table III

Entry Code	F Max	Conduit I.D.		Shrink Boot
		Min	Max	
06	.53 (13.5)	.16 (4.1)	.19 (4.8)	770-001S103
09	.63 (16.0)	.24 (6.1)	.28 (7.1)	770-001S103
12	.73 (18.5)	.33 (8.4)	.37 (9.4)	770-001S104
16	.86 (21.8)	.45 (11.4)	.50 (12.7)	770-001S104
20	.98 (24.9)	.57 (14.5)	.62 (15.8)	770-001S105
24	1.15 (29.2)	.69 (17.5)	.75 (19.1)	770-001S106
28	1.27 (32.3)	.81 (20.6)	.87 (22.2)	770-001S107
32	1.40 (35.6)	.93 (23.6)	1.00 (25.4)	770-001S107
40	1.62 (41.1)	1.18 (30.0)	1.25 (31.8)	770-001S107

**Direct-attachment Guardian Y transition**

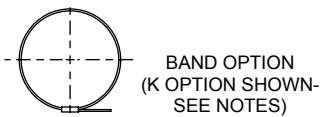
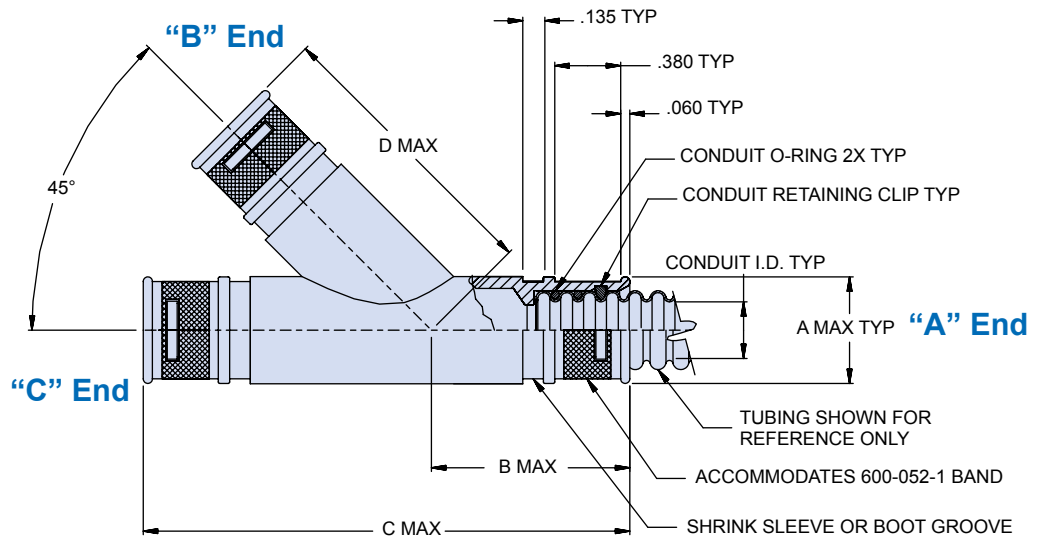
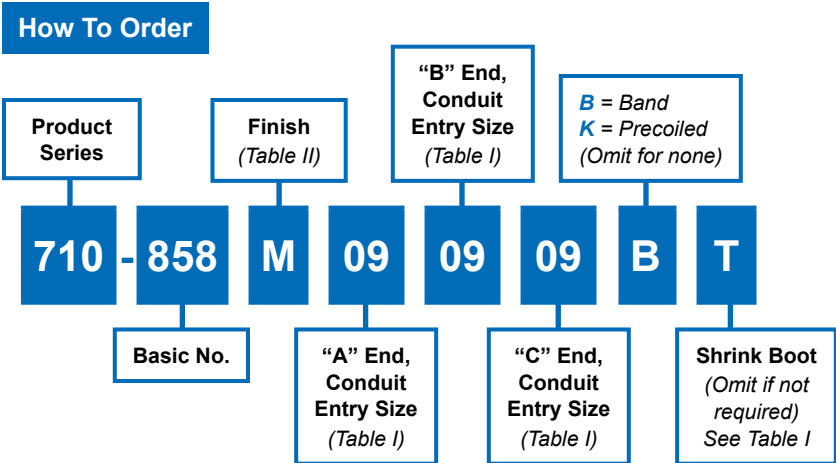

**Material and Finish**

Transition: See Table II  
 O-ring: Silicone/NA  
 Retaining clip: High-grade engineering thermoplastic/NA

**Tools and Assembly notes**

Conduit retaining clip and conduit O-rings to be supplied unassembled  
 Glenair assembly procedure AP74-010 is recommended for adapter to conduit termination  
 Glenair 600 Series backshell assembly tools are recommended for assembly and installation

710-858

**Direct Attachment Guardian Y Transition  
For Series 72 Annular Convuluted Tubing**



Series 72  
Guardian

Table I							
Entry Size	A Max	Conduit I.D.		B Max	C Max	D Max	Shrink Boot Ref
		Min	Max				
06	.53 (13.5)	.16 (4.1)	.19 (4.8)	1.033 (26.2)	2.816 (71.5)	1.782 (45.3)	770-001S103
09	.63 (16.0)	.24 (6.1)	.28 (7.1)	1.053 (26.7)	2.950 (74.9)	1.897 (48.2)	770-001S103
12	.73 (18.5)	.33 (8.4)	.37 (9.4)	1.075 (27.3)	3.099 (78.7)	2.024 (51.4)	770-001S104
16	.86 (21.8)	.45 (11.4)	.50 (12.7)	1.102 (28.0)	3.282 (83.4)	2.181 (55.4)	770-001S104
20	.98 (24.9)	.57 (14.5)	.62 (15.7)	1.127 (28.6)	3.452 (87.7)	2.326 (59.1)	770-001S105
24	1.15 (29.2)	.69 (17.5)	.75 (19.1)	1.162 (29.5)	3.693 (93.8)	2.531 (64.3)	770-001S106
28	1.27 (32.3)	.81 (2.6)	.87 (22.1)	1.187 (30.1)	3.868 (98.2)	2.676 (68.0)	770-001S107
32	1.40 (35.6)	.93 (23.6)	1.00 (25.4)	1.214 (30.8)	4.046 (102.8)	2.833 (72.0)	770-001S107
40	1.62 (41.1)	1.18 (3.0)	1.25 (31.8)	1.259 (32.0)	4.357 (110.7)	3.098 (78.7)	770-001S107

Table II		
Sym	Material	Finish Description
M	Aluminum	Electroless Nickel
MT		Nickel-PTFE
NF		Cad/Olive Drab over Electroless Nickel
ZN		Zinc Nickel/Olive Drab over Electroless Nickel
ZNU		Zinc Nickel/Black over Electroless Nickel
Z1	Stainless Steel	Passivate

**Direct-attachment Guardian double-Y transition**



**How To Order**

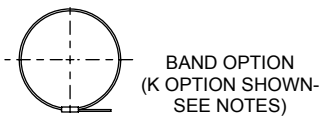
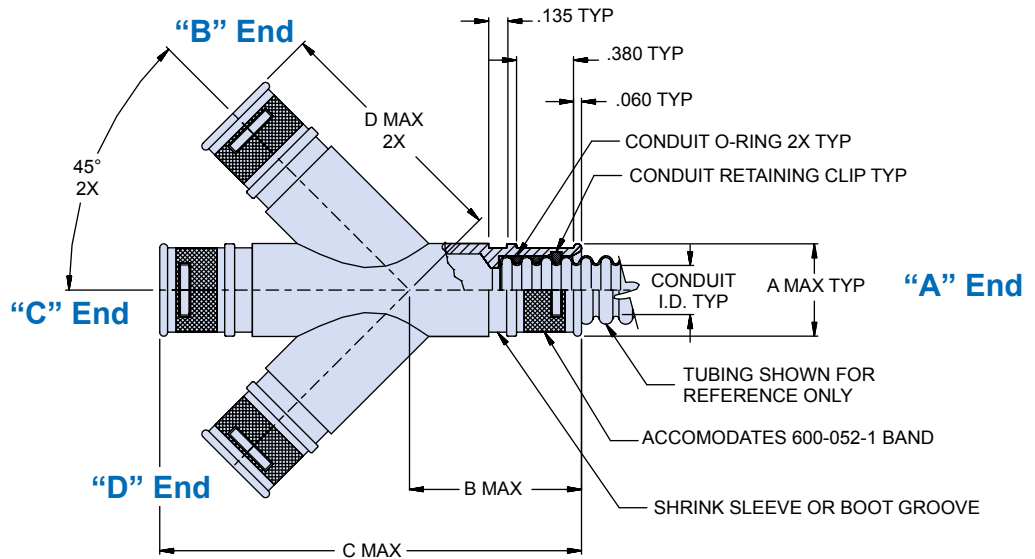
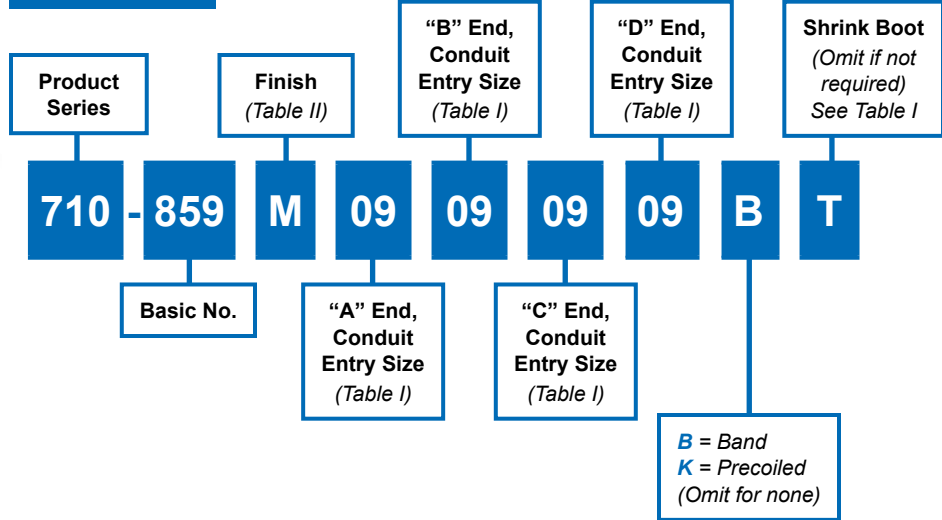

**Material and Finish**

Transition: See Table II  
O-ring: Silicone/NA  
Retaining clip: High-grade engineering thermoplastic/NA

**Tools and Assembly notes**

Conduit retaining clip and conduit O-rings to be supplied unassembled  
Glenair assembly procedure AP74-010 is recommended for adapter to conduit termination  
Glenair 600 Series backshell assembly tools are recommended for assembly and installation

710-859

**Direct Attachment Guardian Double-Y Transition  
For Series 72 Annular Convuluted Tubing**



Series 72  
Guardian

Table I							
Entry Size	A Max	Conduit I.D.		B Max	C Max	D Max	Shrink Boot Ref
		Min	Max				
06	.53 (13.5)	.16 (4.1)	.19 (4.8)	1.033 (26.2)	2.816 (71.5)	1.782 (45.3)	770-001S103
09	.63 (16.0)	.24 (6.1)	.28 (7.1)	1.053 (26.7)	2.950 (74.9)	1.897 (48.2)	770-001S103
12	.73 (18.5)	.33 (8.4)	.37 (9.4)	1.075 (27.3)	3.099 (78.7)	2.024 (51.4)	770-001S104
16	.86 (21.8)	.45 (11.4)	.50 (12.7)	1.102 (28.0)	3.282 (83.4)	2.181 (55.4)	770-001S104
20	.98 (24.9)	.57 (14.5)	.62 (15.7)	1.127 (28.6)	3.452 (87.7)	2.326 (59.1)	770-001S105
24	1.15 (29.2)	.69 (17.5)	.75 (19.1)	1.162 (29.5)	3.693 (93.8)	2.531 (64.3)	770-001S106
28	1.27 (32.3)	.81 (2.6)	.87 (22.1)	1.187 (30.1)	3.868 (98.2)	2.676 (68.0)	770-001S107
32	1.40 (35.6)	.93 (23.6)	1.00 (25.4)	1.214 (30.8)	4.046 (102.8)	2.833 (72.0)	770-001S107
40	1.62 (41.1)	1.18 (3.0)	1.25 (31.8)	1.259 (32.0)	4.357 (110.7)	3.098 (78.7)	770-001S107

Table II		
Sym	Material	Finish Description
M	Aluminum	Electroless Nickel
MT		Nickel-PTFE
NF		Cad/Olive Drab over Electroless Nickel
ZN		Zinc Nickel/Olive Drab over Electroless Nickel
ZNU		Zinc Nickel/Black over Electroless Nickel
ZI	Stainless Steel	Passivate

**Direct-attachment Guardian T transition**



**How To Order**

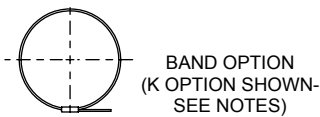
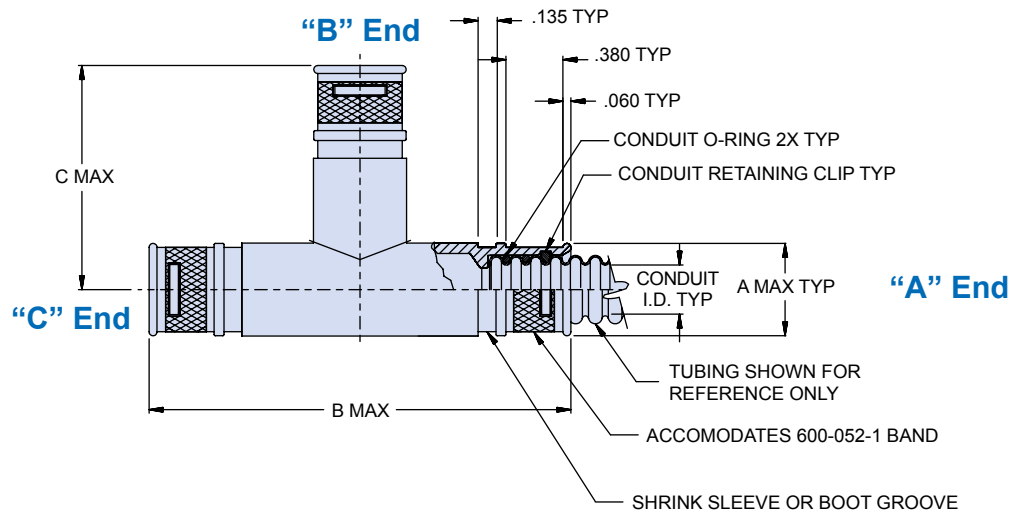
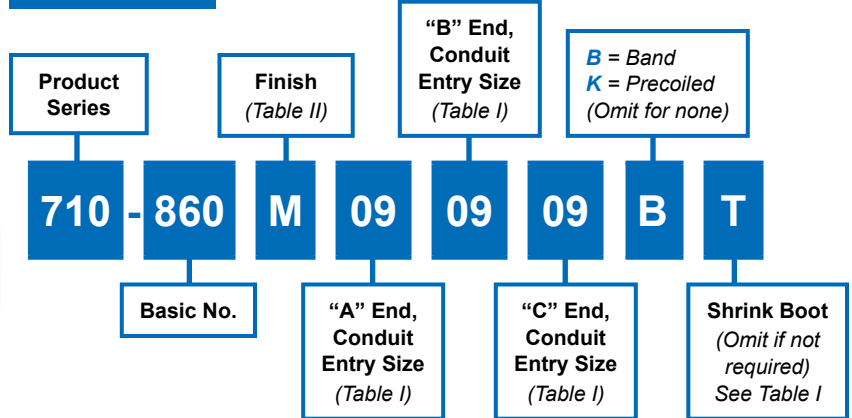

**Material and Finish**

Transition: See Table II  
 O-ring: Silicone/NA  
 Retaining clip: High-grade engineering thermoplastic/NA

**Tools and Assembly notes**

Conduit retaining clip and conduit O-rings to be supplied unassembled  
 Glenair assembly procedure AP74-010 is recommended for adapter to conduit termination  
 Glenair 600 Series backshell assembly tools are recommended for assembly and installation

**710-860**  
**Direct Attachment Guardian T Transition**  
**For Series 72 Annular Convulated Tubing**



**Table I**

Entry Size	A Max	Conduit I.D.		B Max	C Max	Shrink Boot Ref
		Min	Max			
06	.53 (13.5)	.16 (4.1)	.19 (4.8)	2.359 (59.9)	1.180 (30.0)	770-001S103
09	.63 (16.0)	.24 (6.1)	.28 (7.1)	2.454 (62.3)	1.227 (31.2)	770-001S103
12	.73 (18.5)	.33 (8.4)	.37 (9.4)	2.559 (65.0)	1.280 (32.5)	770-001S104
16	.86 (21.8)	.45 (11.4)	.50 (12.7)	2.689 (68.3)	1.345 (34.2)	770-001S104
20	.98 (24.9)	.57 (14.5)	.62 (15.7)	2.809 (71.3)	1.405 (35.7)	770-001S105
24	1.15 (29.2)	.69 (17.5)	.75 (19.1)	2.979 (75.7)	1.490 (37.8)	770-001S106
28	1.27 (32.3)	.81 (2.6)	.87 (22.1)	3.099 (78.7)	1.550 (39.4)	770-001S107
32	1.40 (35.6)	.93 (23.6)	1.00 (25.4)	3.229 (82.0)	1.615 (41.0)	770-001S107
40	1.62 (41.1)	1.18 (3.0)	1.25 (31.8)	3.449 (87.6)	1.725 (43.8)	770-001S107

**Table II**

Sym	Material	Finish Description
M	Aluminum	Electroless Nickel
MT		Nickel-PTFE
NF		Cad/Olive Drab over Electroless Nickel
ZN		Zinc Nickel/Olive Drab over Electroless Nickel
ZNU		Zinc Nickel/Black over Electroless Nickel
Z1	Stainless Steel	Passivate

**Direct-attachment Guardian double-T transition**



**How To Order**

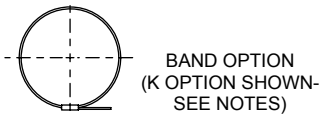
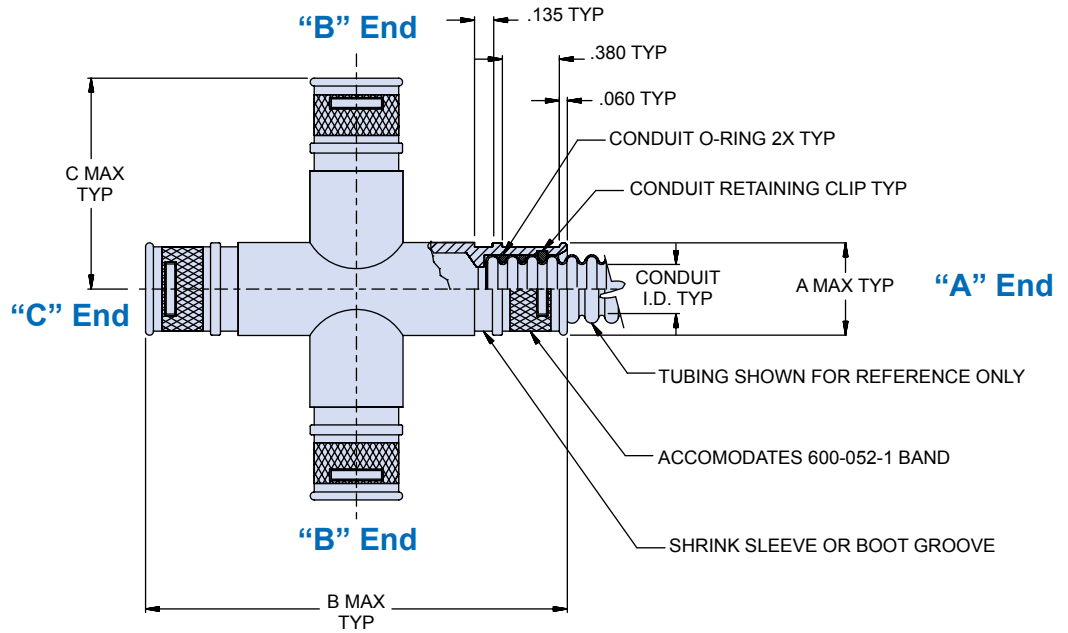
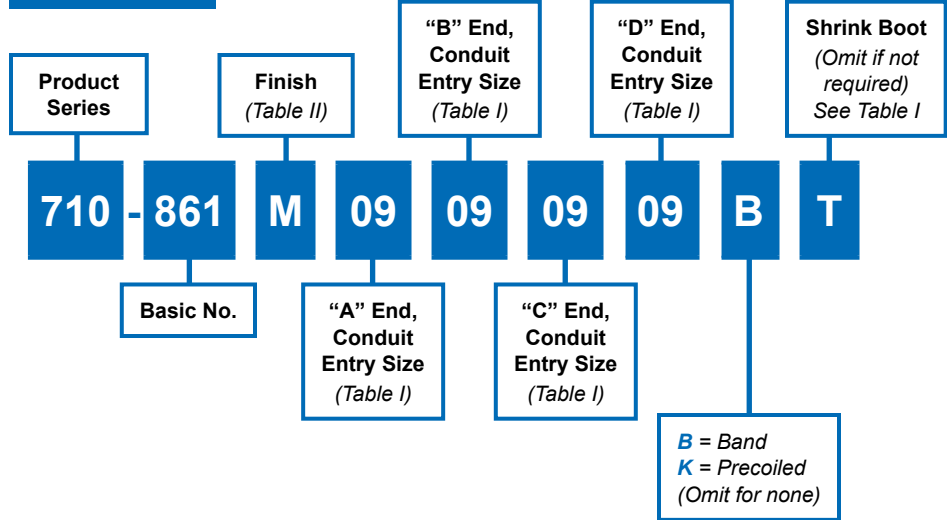

**Material and Finish**

Transition: See Table II  
 O-ring: Silicone/NA  
 Retaining clip: High-grade engineering thermoplastic/NA

**Tools and Assembly notes**

Conduit retaining clip and conduit O-rings to be supplied unassembled  
 Glenair assembly procedure AP74-010 is recommended for adapter to conduit termination  
 Glenair 600 Series backshell assembly tools are recommended for assembly and installation



**710-861**  
**Direct Attachment Guardian Double-T Transition**  
**For Series 72 Annular Convuluted Tubing**



Series 72  
Guardian

Table I						
Entry Size	A Max	Conduit I.D.		B Max	C Max	Shrink Boot Ref
		Min	Max			
06	.53 (13.5)	.16 (4.1)	.19 (4.8)	2.359 (59.9)	1.180 (30.0)	770-001S103
09	.63 (16.0)	.24 (6.1)	.28 (7.1)	2.454 (62.3)	1.227 (31.2)	770-001S103
12	.73 (18.5)	.33 (8.4)	.37 (9.4)	2.559 (65.0)	1.280 (32.5)	770-001S104
16	.86 (21.8)	.45 (11.4)	.50 (12.7)	2.689 (68.3)	1.345 (34.2)	770-001S104
20	.98 (24.9)	.57 (14.5)	.62 (15.7)	2.809 (71.3)	1.405 (35.7)	770-001S105
24	1.15 (29.2)	.69 (17.5)	.75 (19.1)	2.979 (75.7)	1.490 (37.8)	770-001S106
28	1.27 (32.3)	.81 (2.6)	.87 (22.1)	3.099 (78.7)	1.550 (39.4)	770-001S107
32	1.40 (35.6)	.93 (23.6)	1.00 (25.4)	3.229 (82.0)	1.615 (41.0)	770-001S107
40	1.62 (41.1)	1.18 (3.0)	1.25 (31.8)	3.449 (87.6)	1.725 (43.8)	770-001S107

Table II		
Sym	Material	Finish Description
M	Aluminum	Electroless Nickel
MT		Nickel-PTFE
NF		Cad/Olive Drab over Electroless Nickel
ZN		Zinc Nickel/Olive Drab over Electroless Nickel
ZNU		Zinc Nickel/Black over Electroless Nickel
Z1	Stainless Steel	Passivate

**Y transition with self-locking feature for ease of assembly and repair for multi-legged conduit assemblies. Use H code conduit fittings to interface.**

**How To Order**

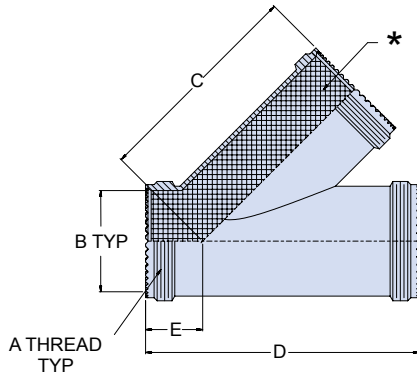
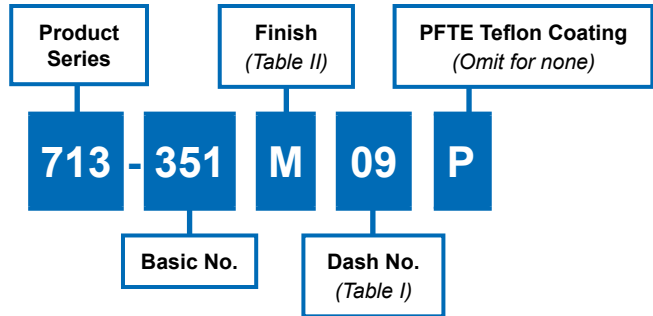

Sym	Material	Finish Description
M	Aluminum	Electroless Nickel
MT		Nickel-PTFE
NF		Cad/Olive Drab over Electroless Nickel
ZN		Zinc Nickel/Olive Drab over Electroless Nickel
ZNU		Zinc Nickel/Black over Electroless Nickel
Z1	Stainless Steel	Passivate

Dash No	Conduit Size (Ref)	A Thread Iso Metric	B Dia	C Max	D Max	E Max
09	06,09	M12 x 1.0-6g	.281 (7.1)	1.38 (35.1)	1.87 (47.5)	.52 (13.2)
11	10,12	M15 x 1.0-6g	.397 (10.1)	1.60 (40.6)	2.11 (53.6)	.54 (13.7)
13	14,16	M18 x 1.0-6g	.511 (13.0)	1.75 (44.5)	2.28 (57.9)	.57 (14.5)
15	20	M22 x 1.0-6g	.636 (16.2)	1.90 (48.3)	2.47 (62.7)	.60 (15.2)
17	24	M25 x 1.0-6g	.761 (19.3)	2.09 (53.1)	2.69 (68.3)	.63 (16.0)
19	28	M28 x 1.0-6g	.875 (22.2)	2.22 (56.4)	2.84 (72.1)	.65 (16.5)
21	32	M31 x 1.0-6g	1.000 (25.4)	2.36 (59.9)	3.00 (76.2)	.68 (17.3)
23	36	M34 x 1.0-6g	1.125 (28.6)	2.50 (63.5)	3.17 (80.5)	.70 (17.8)
25	40	M37 x 1.0-6g	1.250 (31.8)	2.66 (67.6)	3.35 (85.1)	.73 (18.5)
33	48	M45 x 1.5-6g	1.530 (38.9)	3.10 (78.7)	3.87 (98.3)	.80 (20.3)
37	56	M50 x 1.5-6g	1.750 (44.5)	3.39 (86.1)	4.21 (106.9)	.84 (21.3)

**Material and Finish**

See Table II.

\*Internal Surface coated with Teflon as shown, see P/N development.

# 713-352 Double-Y Transition



Series 72  
Guardian

**Double-Y transition with self-locking feature for ease of assembly and repair for multi-legged conduit assemblies. Use H code conduit fittings to interface.**

### How To Order

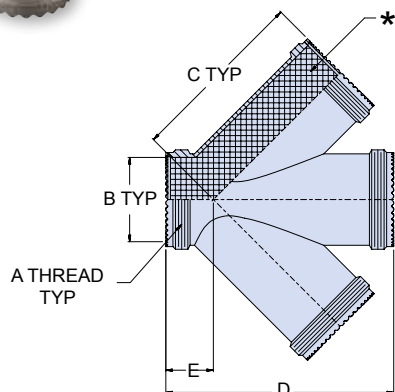
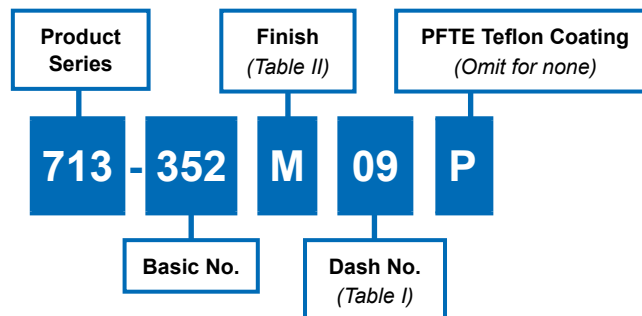

Sym	Material	Finish Description
M	Aluminum	Electroless Nickel
MT		Nickel-PTFE
NF		Cad/Olive Drab over Electroless Nickel
ZN		Zinc Nickel/Olive Drab over Electroless Nickel
ZNU		Zinc Nickel/Black over Electroless Nickel
Z1	Stainless Steel	Passivate

Dash No	Conduit Size (Ref)	A Thread Iso Metric	B Dia	C Max	D Max	E Max
09	06,09	M12 x 1.0-6g	.281 (7.1)	1.38 (35.1)	1.87 (47.5)	.52 (13.2)
11	10,12	M15 x 1.0-6g	.397 (10.1)	1.60 (40.6)	2.11 (53.6)	.54 (13.7)
13	14,16	M18 x 1.0-6g	.511 (13.0)	1.75 (44.5)	2.28 (57.9)	.57 (14.5)
15	20	M22 x 1.0-6g	.636 (16.2)	1.90 (48.3)	2.47 (62.7)	.60 (15.2)
17	24	M25 x 1.0-6g	.761 (19.3)	2.09 (53.1)	2.69 (68.3)	.63 (16.0)
19	28	M28 x 1.0-6g	.875 (22.2)	2.22 (56.4)	2.84 (72.1)	.65 (16.5)
21	32	M31 x 1.0-6g	1.000 (25.4)	2.36 (59.9)	3.00 (76.2)	.68 (17.3)
23	36	M34 x 1.0-6g	1.125 (28.6)	2.50 (63.5)	3.17 (80.5)	.70 (17.8)
25	40	M37 x 1.0-6g	1.250 (31.8)	2.66 (67.6)	3.35 (85.1)	.73 (18.5)
33	48	M45 x 1.5-6g	1.530 (38.9)	3.10 (78.7)	3.87 (98.3)	.80 (20.3)
37	56	M50 x 1.5-6g	1.750 (44.5)	3.39 (86.1)	4.21 (106.9)	.84 (21.3)

### Material and Finish

See Table II.

\*Internal Surface coated with Teflon as shown, see P/N development.

**T transition with self-locking feature for ease of assembly and repair for multi-legged conduit assemblies. Use H code conduit fittings to interface.**



**How To Order**

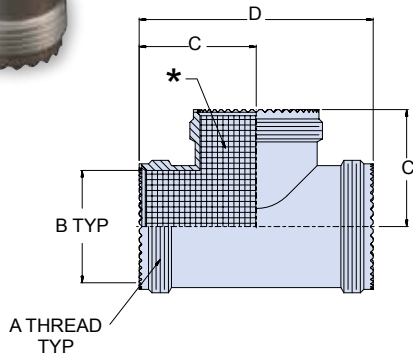
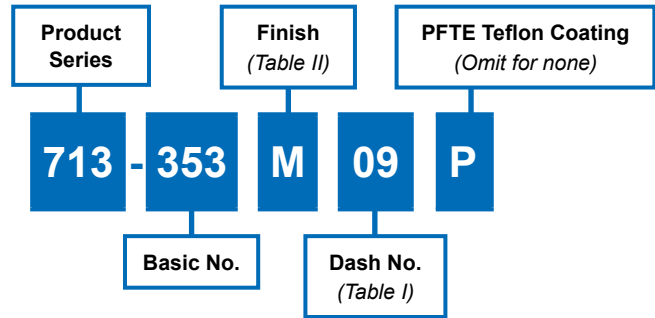

Sym	Material	Finish Description
M	Aluminum	Electroless Nickel
MT		Nickel-PTFE
NF		Cad/Olive Drab over Electroless Nickel
ZN		Zinc Nickel/Olive Drab over Electroless Nickel
ZNU		Zinc Nickel/Black over Electroless Nickel
Z1	Stainless Steel	Passivate

Dash No	Conduit Size (Ref)	A Thread Iso Metric	B Dia	C Max	D Max
09	06,09	M12 X 1.0-6g	.281 (7.1)	.78 (19.8)	1.53 (38.9)
11	10,12	M15 X 1.0-6g	.397 (10.1)	.90 (22.9)	1.71 (43.4)
13	14,16	M18 X 1.0-6g	.511 (13.0)	.94 (23.9)	1.84 (46.7)
15	20	M22 X 1.0-6g	.636 (16.2)	1.00 (25.4)	1.96 (49.8)
17	24	M25 X 1.0-6g	.761 (19.3)	1.08 (27.4)	2.12 (53.8)
19	28	M28 X 1.0-6g	.875 (22.2)	1.13 (28.7)	2.23 (56.6)
21	32	M31 X 1.0-6g	1.000 (25.4)	1.19 (30.2)	2.34 (59.4)
23	36	M34 X 1.0-6g	1.125 (28.6)	1.25 (31.8)	2.46 (62.5)
25	40	M37 X 1.0-6g	1.250 (31.8)	1.31 (33.3)	2.59 (65.8)
33	48	M45 X 1.5-6g	1.530 (38.9)	1.49 (37.8)	2.95 (74.9)
37	56	M50 X 1.5-6g	1.750 (44.5)	1.62 (41.1)	3.21 (81.5)

**Material and Finish**

See Table II.

\*Internal Surface coated with Teflon as shown, see P/N development.

# 713-354 Double-T Transition



**Double-T transition with self-locking feature for ease of assembly and repair for multi-legged conduit assemblies. Use H code conduit fittings to interface.**



### How To Order

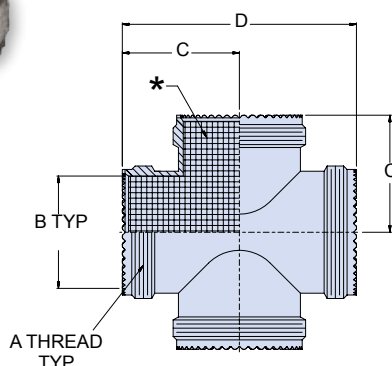
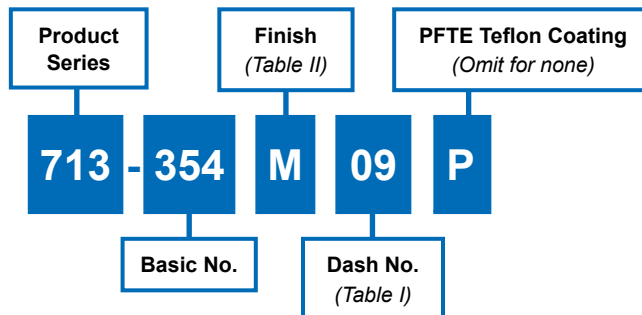

Sym	Material	Finish Description
M	Aluminum	Electroless Nickel
MT		Nickel-PTFE
NF		Cad/Olive Drab over Electroless Nickel
ZN		Zinc Nickel/Olive Drab over Electroless Nickel
ZNU		Zinc Nickel/Black over Electroless Nickel
Z1	Stainless Steel	Passivate

Dash No	Conduit Size (Ref)	A Thread Iso Metric	B Dia	C Max	D Max
09	06,09	M12 X 1.0-6g	.281 (7.1)	.78 (19.8)	1.53 (38.9)
11	10,12	M15 X 1.0-6g	.397 (10.1)	.90 (22.9)	1.71 (43.4)
13	14,16	M18 X 1.0-6g	.511 (13.0)	.94 (23.9)	1.84 (46.7)
15	20	M22 X 1.0-6g	.636 (16.2)	1.00 (25.4)	1.96 (49.8)
17	24	M25 X 1.0-6g	.761 (19.3)	1.08 (27.4)	2.12 (53.8)
19	28	M28 X 1.0-6g	.875 (22.2)	1.13 (28.7)	2.23 (56.6)
21	32	M31 X 1.0-6g	1.000 (25.4)	1.19 (30.2)	2.34 (59.4)
23	36	M34 X 1.0-6g	1.125 (28.6)	1.25 (31.8)	2.46 (62.5)
25	40	M37 X 1.0-6g	1.250 (31.8)	1.31 (33.3)	2.59 (65.8)
33	48	M45 X 1.5-6g	1.530 (38.9)	1.49 (37.8)	2.95 (74.9)
37	56	M50 X 1.5-6g	1.750 (44.5)	1.62 (41.1)	3.21 (81.5)

### Material and Finish

See Table II.

\*Internal Surface coated with Teflon as shown, see P/N development.



# Assembly Instructions

## for Series 72 Annular Convolute Tubing and Guardian Adapters and Fittings

### O-Ring Attachment

**Step 1** Install pair of provided O-rings on the two forwardmost tubing convolutes

**Step 2** Insert tubing into fitting

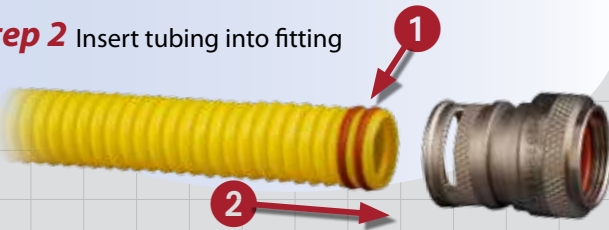

### Retention Ring Attachment

**Step 3** Run provided retaining clip into slot, aligned with the third convolution of conduit, behind the 2 O-rings.

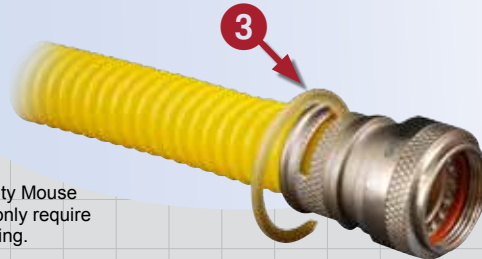

Note: Mighty Mouse connectors only require 1 o-ring.

### BAND-IT® Band Termination

#### Cable Prep

**Step 1** Pull overall braid shield over the band platform so that all braid strands will be captured by the band.



#### Install Band

**Step 2** Wrap the band through the buckle twice. Insert the free end into the banding tool in the direction shown on the tool. Squeeze the short grey handle to insert the band. Slide the band onto the cable. Close the black handle repeatedly until the handle no longer opens. Close the long grey handle until the tool cuts the band. Remove the excess strap from the tool by closing the small grey handle.



#### Trim Braid

**Step 3** It's a snap! Just trim the excess braid and you're done.



### Shrink Boot Attachment

**Step 1** Position the boot so that the lipped "A" end is on the adapter, and the "C" end is on the conduit.

**Step 2** Apply heat to adapter end of boot until the lipped end recovers fully and fits into the groove of the adapter.

**Step 3** Continue to heat down the body of the boot towards the "C" end, applying heat in brush-like strokes until "C" end is fully recovered.

**Step 4** After the boot is fully recovered, apply additional heat as necessary to the entire boot to ensure good adhesion. Do not overheat as conduit can be damaged by excessive heating.

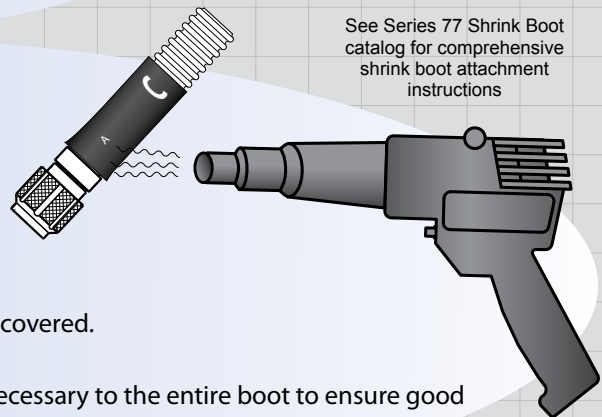

See Series 77 Shrink Boot catalog for comprehensive shrink boot attachment instructions

**TG69**  
**Soft Jaw Pliers**



**Soft Jaw Pliers**

**How To Order**

**Basic  
Number**

**TG69 - P**

**Finish**

*P - Nickel Plate  
(Omit for Standard  
Cad/Bright Dip)*

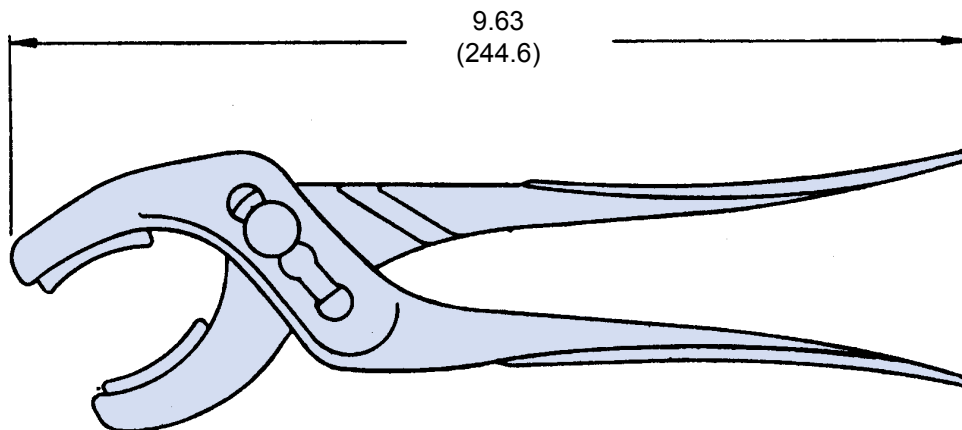

NOTE: NOT RECOMMENDED FOR COMPOSITE COUPLING NUTS (USE 600-091 OR 600-157)

**Notes:**

Assembly identified per MIL-STD-130  
Nylon replacement inserts: P/N G77015



# TG70 Connector Strap Wrench with 3/8" Square Drive

## Connector strap wrench

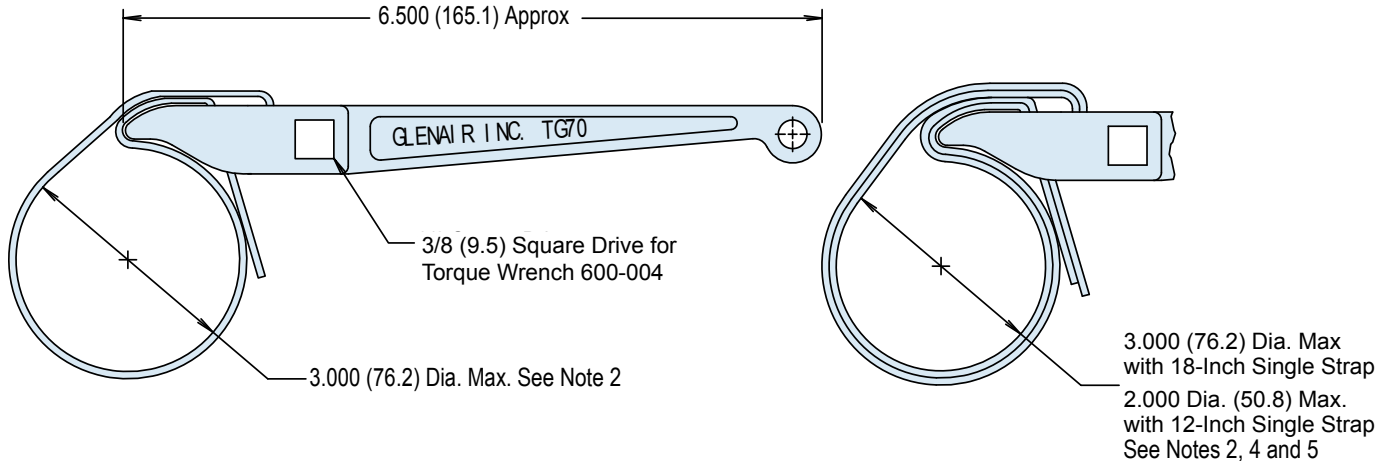

<b>Basic Part Number</b>	<b>Torque Wrench (Omit for None)</b>
<b>TG70 - 1 - 18</b>	

**Strap Length in Inches (See Notes 2 and 4)**  
 Lengths Available: 12, 18, 24 and 36-Inch Only  
 Standard length is 12 Inches,  
 Omit Dash Number for Standard

- ### APPLICATION NOTES
- These wrenches are made of the following materials:  
 Wrench Handle - Aluminum Alloy/Nickel Plate.  
 Wedge - Stainless Steel/Passivated.  
 Strap - Impregnated Fabric. Straps are 1/2 inch (12.7) in width.
  - Replacement straps are available. Specify part number G70515-xx for 12, 18, 24 or 36-inch strap. 24 and 36 inch for double wrap.
  - Metric dimensions (mm) are indicated in parentheses.
  - Double wrap as shown for heavy duty range.
  - Not recommended for composite coupling nuts (use 600-091 or 600-157).

### VARIANCE CHART

TG-70 Strap Wrench Used with Glenair Torque Wrenches

Accessory Shell Size	Recommended Installation Torque			
	Light/Medium Duty ± 5 Inch Pounds		Heavy Duty ± 5 Inch Pounds	
	TG70 Torque	Part Torque	TG70 Torque	Part Torque
08/09	28	35	45	60
10/11	28	35	70	80
12/13	30	40	75	110 [80]
14/15	30	40	75	120 [80]
16/17	30	40	75	120 [80]
18/19	30	40	75	120 [80]
20/21	75	80	95	140 [100]
22/23	75	80	120*	140
24/25	75	80	120*	140
28			135*	150
32			150*	150
36			150*	150

\* TG70 Not Recommended For Values of 120 Inch Lbs. or Greater.

- ### VARIANCE CHART NOTES
- Recommended installation torque is approximately 80% of MIL-C-85049 accessory thread strength values.
  - Heavy duty installation torque values may be difficult to attain with the TG70 Strap Wrench; the values shown in brackets [ ] are the maximum attainable with the TG70 Strap Wrench using a single wrap.
  - Glenair recommends using 600 series torque tools whenever possible. When torque loading exceeds 75 inch pounds, or to attain the heavy duty torque values shown, a double wrap strap provides suitable friction to achieve torque values.
  - Glenair recommends that heavy duty torque values be directly read through the connector shell body with the use of 600-005 connectors holding tools.



600-164

**Large Broad Blade Utility Shear**  
for Cutting Metal-Clad Composite Braided Shielding,  
Rubber, Cable Jacketing, Cable, Plastics and Rope



Series 72  
Guardian

### **Broad blade utility shear**

How To Order

Product  
Series

Basic  
Number

600 - 164



- *Nickel Chrome Plating Resists Corrosion and Rusting*
- *Broad, Short Jaws Provide Powerful Cutting Action*
- *Extended Handle Provides Comfort and Cutting Leverage*
- *High Leverage Provides Powerful Cutting Action for Light Metals, Rubber and Heavy Fabrics*
- *Cuts Rubber, Cables, Light Metal, Wire Metal Screens and Braided EMI/EMP Shielding, Cordage, Plastics and Rope*
- *Weight: 0.55 Pounds*
- *Shear Cut Length: 2.000 (51.0)*

#### **Recommended EMI Braid Cutting Procedure**



**Note:** When cutting braid, both metal and especially composite, open cutter blades to allow the full 2" cut. Place braid all the way back onto blades as shown.

#### **Notes:**

Always wear approved eye protection  
Never use on or near live electrical circuits



# BAND-IT® Shield Termination System

## BAND-IT® shield termination system

### Fast, Cost-Effective Shield Termination

Attach cable braid shields to EMI backshells with **BAND-IT®** stainless steel straps. The **BAND-IT®** system offers fast termination and the flexibility to handle different diameters with the same band.

#### IMPORTANT NOTE: ALWAYS DOUBLE-WRAP BANDS!

Contact Glenair or visit our website (glenair.com) to view our complete line of BAND-IT® products, including pneumatic tools for high production and calibration kits.

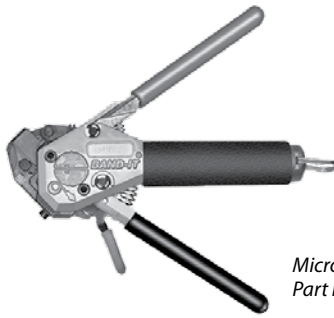

Micro Band Tool  
Part Number 600-061

Standard Band Tool  
Part Number 600-058  
1.18 lbs. / 6.75 Inches (172mm.) Length



### How To Order Bands

Band Type	Width		Length		Part Number		Use With Tool	Accommodates Dia.	
	In.	mm.	In.	mm.	Uncoiled	Coiled		In.	mm.
Micro Band, Standard Length	.120	3.05	8.125	206.38	600-057	600-057-1	600-061	.88	22.35
Micro Band, Extended Length	.120	3.05	14.25	361.95	600-083	600-083-1	600-061	1.88	47.75
Standard Band, Standard Length	.240	6.10	14.256	362.10	600-052	600-052-1	600-058	1.80	45.72
Standard Band, Extended Length	.240	6.10	18.00	457.20	600-090	600-090-1	600-058	2.50	63.50

## BAND-IT® Shield Termination Instructions

1. Prepare Cable Braid for termination process (Figure 1).
2. Push Braid forward over Adapter Retention Lip to the Adapter Incline Point (or .4" [10.2mm] minimum braid length). Milk Braid as required to remove slack and insure a snug fit around the shield termination area (Figure 2).
3. Prepare the Band in the following manner: **IMPORTANT:** Due to Connector/Adapter circumference, it may be necessary to prepare the Band around the Cable or Retention Area.
  - A. Roll Band through the Buckle Slot twice. (Bands must be double-coiled.)
  - B. Pull on Band until Mark (▷) is within approximately .250 inch (6.4mm) of Buckle Slot (Figure 3). The Band may be tightened further if desired.

**NOTE:** Prepared Band should have (▷) Mark visible approximately where shown in Figure 3.

### Shield Termination Clamping Process (Figures 4 thru 8)

**NOTE:** To free Tool Handles, move Holding Clips to center of Tool.

4. Squeeze Gripper Release Lever and insert Band into the front end opening of the Tool. (**NOTE:** Circular portion of looped band must always face downward.)
5. Aligning the Band and Tool with the Shield Termination Area, squeeze Black Pull-Up Handle repeatedly using short strokes until it locks against Tool Body. (This indicates the Band is compressed to the Tool Pre-calibrated Tension.)

**NOTE:** If alignment of band and shield is unsatisfactory, tension on band can be relaxed by pushing on slotted release lever on top of tool. Make adjustments as necessary and again squeeze black pull-up handle.

6. Complete the Clamping Process by squeezing the Gray Cut-Off Handle.
7. Remove excess band from tool and dispose.
8. Inspect Shield Termination.

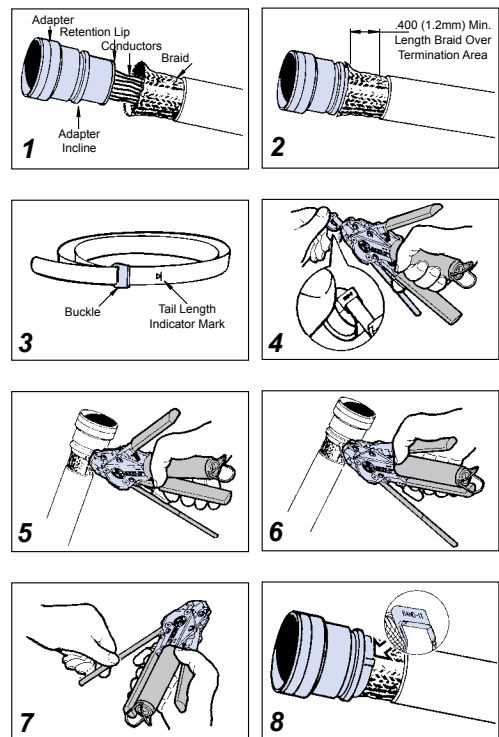

## Environmental Shrink Boots: Overview and materials selection



**Protect Your Guardian Assembly** with heat-shrinkable boots. These easy-to-use boots provide excellent electrical, mechanical and environmental protection. Heating the boot causes the boot to shrink onto the conduit fitting or transition. These lipped boots attach directly to all Guardian fittings. After shrinking, the boot lip locks into groove. Standard Guardian system boots are Type 1 High Performance Elastomer for extreme temperature range performance, and excellent resistance to fuels and oils. The standard Guardian boot also includes an eylet for attachment of dust caps or protective covers. Part numbers are shown in the table at right. Other boot materials, adhesives and options are shown in the following pages.

Standard Guardian Boots		
Boot Size	Part Number	Ref Conduit I.D. / Size
03	<a href="#">770-001S103</a>	06,09
04	<a href="#">770-001S104</a>	12,16
05	<a href="#">770-001S105</a>	20
06	<a href="#">770-001S106</a>	24
07	<a href="#">770-001S107</a>	28,32,40

### Material Selection Guide

Attribute	Type 1 High Performance Semi-Rigid Elastomer	Type 2 Zero Halogen Semi-Rigid Polyolefin	Type 3 Flexible Polyolefin
Continuous Operating Temp.	-75° to +150°C	-30° to +125°C	-55° to +135°
Resistance to Fuels, Oils	Excellent	Very Good	Good
Low Toxicity, Zero Halogen	No	Yes	No

### Type 1 High Performance Elastomer

Semi-rigid high performance boots combine excellent resistance to fuels, oils and solvents with superior performance at extreme temperatures. Rated for 3000 hours continuous operation at +150° C, these boots fit directly to Guardian fittings and adapters for superior environmental protection and strain-relief. Material meets the requirements of VG95343 Part 6, BSG 198-5-DE, EN62329-102 and SAE AS5258 Type H. These boots are recommended for demanding applications such as military vehicles and petrochemical exploration. Black color.

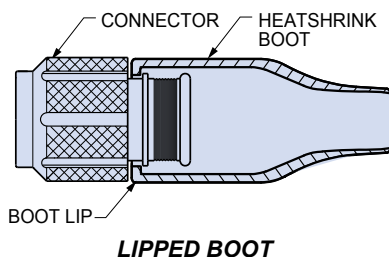

### Type 2 Zero Halogen

Halogen-free polyolefin boots meet low smoke and toxicity requirements of shipboard, transit and aircraft systems. These Low Smoke/Zero Halogen (LSZH) boots fit directly on all Guardian system adapters and fittings. Oxygen index greater than 30%, smoke index less than 20, and toxicity index under 3 per 100 grams. Material meets requirements of NAVSEA 5617649, VG95343 Part 29, BSG 198-5-DF, EN62329-101 and SAE AS5258 Type G. Good resistance to oils, fuels and solvents. These boots provide strain relief and environmental protection to connector/conduit transitions. Temperature rating -30° to +125° C. Black color.

### Type 3 Flexible Polyolefin

Economical flexible polyolefin boots fit directly on all Guardian system adapters and fittings. These self-extinguishing boots meet the requirements of SAE AS81765/1 Type II. Good resistance to oils and fuels. Available with optional hot melt adhesive lining, these boots provide strain relief and environmental protection to connector/cable transitions. Temperature rating -55° to +135° C. Black color.



# Lipped Straight Shrink Boots Type 1, 2, and 3

## Lipped straight shrink boots



Straight boots with lip for attachment to standard circular connector adapters. After shrinking, the boot lip locks into adapter groove. Eyelet hole allows attachment of dust caps or protective covers. Choose Type 1 high performance elastomer for extreme temperatures and excellent resistance to fuels and oils, Type 2 non-halogenated flame-retardant polyolefin for use where limited fire hazard is required, or choose Type 3 general purpose polyolefin for use where occasional exposure to heat and chemicals may occur. Choose boot size based on adapter diameter and cable diameter.

Boot Size	Adapter Dia.				Min. Cable Diameter	
	In.		mm.		In.	mm.
	Min	Max	Min	Max	In.	mm.
00	.250	.325	6.35	8.26	.110	2.79
01	.325	.425	7.62	10.80	.150	3.81
02	.350	.600	8.89	15.24	.175	4.45
03	.450	.850	11.43	21.59	.225	5.72
04	.600	1.000	15.24	25.40	.275	6.99
05	.750	1.200	19.05	30.48	.300	7.62
06	.900	1.350	22.86	34.29	.375	9.53
07	1.250	1.650	31.75	41.91	.425	10.80
08	1.400	2.250	35.56	57.15	.625	15.88
09	1.870	2.470	47.50	62.70	.660	16.80

Attribute	Type 1 High Performance Semi-Rigid Elastomer	Type 2 Zero Halogen Semi-Rigid Polyolefin	Type 3 General Purpose Flexible Polyolefin
Continuous Operating Temp.	-75° to +150°C	-30° to +125°C	-55° to +135°C
Resistance to Fuels, Oils	Excellent	Very Good	Good
Low Toxicity, Zero Halogen	No	Yes	No

Attribute	W2 Standard Hot Melt Adhesive	W1 High Temperature Hot Melt Adhesive	R High Performance Epoxy Adhesive
Boot Material Compatibility	Types 1, 2 and 3	Types 1, 2 and 3	Type 1
Continuous Operating Temp.	-40° to +80°C	-55° to +105°C	-75° to +150°C
Resistance to Fuels, Oils, and Fluids	Good	Good	Excellent
Low Toxicity, Zero Halogen	Yes	Yes	Yes

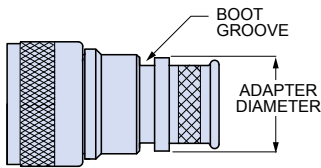

## Lipped straight shrink boots- Type 1 high performance elastomer

- 75° C to +150° C
- Excellent resistance to fuels, oils, solvents and heat.

Semi-rigid high performance boots combine excellent resistance to fuels, oils and solvents with superior performance at extreme temperatures. Rated for 3000 hours continuous operation at +150° C, these boots fit most standard boot adapters for circular connectors. Material meets the requirements of VG95343 Type 6, BSG 198-5-DE, EN62329-102 and SAE AS5258 Type H. These boots are recommended for demanding applications such as military vehicles and petrochemical exploration. Choose standard length or short length if space is limited. Black color.

Boot Size	Part Number with Eyelet				Part Number without Eyelet				
	Guardian Standard Boots: No Adhesive Lining	Pre-Coated with W1 Hi-Temp Hot-Melt Adhesive	Pre-Coated with W2 Standard Hot-Melt Adhesive	Pre-Coated with R Epoxy Adhesive	No Adhesive Lining	Pre-Coated with W1 Hi-Temp Hot-Melt Adhesive	Pre-Coated with W2 Standard Hot-Melt Adhesive	Pre-Coated with R Epoxy Adhesive	Ref Conduit I.D./ Size
03	770-001S103	770-001S103W1	770-001S103W2	770-001S103R	770-003S103	770-003S103W1	770-003S103W2	770-003S103R	06,09
04	770-001S104	770-001S104W1	770-001S104W2	770-001S104R	770-003S104	770-003S104W1	770-003S104W2	770-003S104R	12,16
05	770-001S105	770-001S105W1	770-001S105W2	770-001S105R	770-003S105	770-003S105W1	770-003S105W2	770-003S105R	20
06	770-001S106	770-001S106W1	770-001S106W2	770-001S106R	770-003S106	770-003S106W1	770-003S106W2	770-003S106R	24
07	770-001S107	770-001S107W1	770-001S107W2	770-001S107R	770-003S107	770-003S107W1	770-003S107W2	770-003S107R	28,32,40

## Lipped Straight Shrink Boots Type 1, 2, and 3



### Lipped straight shrink boots- Type 2 zero halogen, semi-rigid



- Low Smoke, Zero Halogen
- Meets U.S. and E.U. toxicity requirements.

Halogen-free polyolefin boots meet low smoke and toxicity requirements of shipboard, transit and aircraft systems. These Low Smoke/Zero Halogen (LSZH) boots fit most standard shrink boot adapters, including M85049 types along with Glenair Series 31 and Series 44 adapters. Oxygen index greater than 30%, smoke index less than 20, and toxicity index under 3 per 100 grams. Material meets requirements of NAVSEA 5617649, VG95343 Part 29, BSG 198-5-DF, EN62329-101 and SAE AS5258 Type G. Good resistance to oils, fuels and solvents. Available high temperature hot melt adhesive lining, these boots provide strain relief and environmental protection to connector/cable transitions. Temperature rating -30° to +125° C. Black color.

Boot Size	Part Number with Eyelet			Part Number without Eyelet			Ref Conduit I.D. / Size
	No Adhesive Lining	Pre-Coated with W1 Hi-Temp Hot-Melt Adhesive	Pre-Coated with W2 Standard Hot-Melt Adhesive	No Adhesive Lining	Pre-Coated with W1 Hi-Temp Hot-Melt Adhesive	Pre-Coated with W2 Standard Hot-Melt Adhesive	
03	770-001S203	770-001S203W1	770-001S203W2	770-003S203	770-003S203W1	770-003S203W2	06,09
04	770-001S204	770-001S204W1	770-001S204W2	770-003S204	770-003S204W1	770-003S204W2	12,16
05	770-001S205	770-001S205W1	770-001S205W2	770-003S205	770-003S205W1	770-003S205W2	20
06	770-001S206	770-001S206W1	770-001S206W2	770-003S206	770-003S206W1	770-003S206W2	24
07	770-001S207	770-001S207W1	770-001S207W2	770-003S207	770-003S207W1	770-003S207W2	28,32,40

### Lipped straight shrink boots- Type 3 polyolefin, flexible

- General purpose harnessing
- Economical, flexible
- -55° C to +135° C

Economical flexible polyolefin boots fit most standard shrink boot adapters, Glenair Series 31 and Series 44 adapters. These self-extinguishing boots meet the requirements of SAE AS81765/1 Type II. Good resistance to oils and fuels. Available with optional hot melt adhesive lining, these boots provide strain relief and environmental protection to connector/cable transitions. Temperature rating -55° to +135° C. Black color.

Boot Size	Part Number with Eyelet			Part Number without Eyelet			Ref Conduit I.D. / Size
	No Adhesive Lining	Pre-Coated with W1 Hi-Temp Hot-Melt Adhesive	Pre-Coated with W2 Standard Hot-Melt Adhesive	No Adhesive Lining	Pre-Coated with W1 Hi-Temp Hot-Melt Adhesive	Pre-Coated with W2 Hot-Melt Adhesive	
03	770-001S303	770-001S303W1	770-001S303W2	770-003S303	770-003S303W1	770-003S303W2	06,09
04	770-001S304	770-001S304W1	770-001S304W2	770-003S304	770-003S304W1	770-003S304W2	12,16
05	770-001S305	770-001S305W1	770-001S305W2	770-003S305	770-003S305W1	770-003S305W2	20
06	770-001S306	770-001S306W1	770-001S306W2	770-003S306	770-003S306W1	770-003S306W2	24
07	770-001S307	770-001S307W1	770-001S307W2	770-003S307	770-003S307W1	770-003S307W2	28,32,40

## Lipped straight shrink boots- dimensions

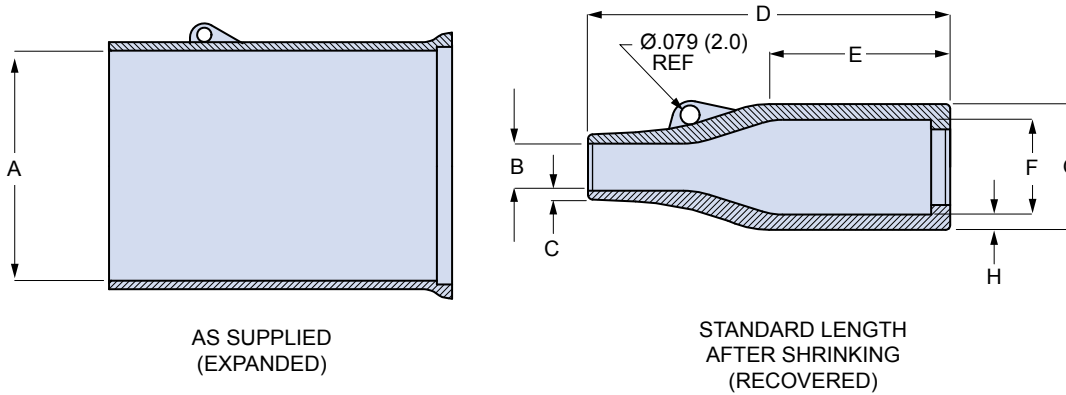

Entry Code	Boot Size	A Min.		B Max.		C ± 20%		D ± 10%		E Ref.		F Max.		G Ref.		H ± 30%	
		In.	mm.	In.	mm.	In.	mm.	In.	mm.	In.	mm.	In.	mm.	In.	mm.	In.	mm.
06, 09	03	.945	24.0	.197	5.0	.035	0.9	1.496	38.0	.748	19.0	.413	10.5	.520	13.2	.063	1.6
12, 16	04	1.181	30.0	.236	6.0	.039	1.0	2.165	55.0	1.181	30.0	.551	14.0	.693	17.6	.071	1.8
20	05	1.260	32.0	.276	7.0	.047	1.2	2.638	67.0	1.299	33.0	.709	18.0	.850	21.6	.071	1.8
24	06	1.417	36.0	.335	8.5	.047	1.2	3.150	80.0	1.575	40.0	.866	22.0	.945	24.0	.079	2.0
28, 32, 40	07	1.693	43.0	.394	10.0	.051	1.3	3.898	99.0	2.165	55.0	1.102	28.0	1.276	32.4	.087	2.2

## Lipped straight shrink boots- part marking, raised lettering

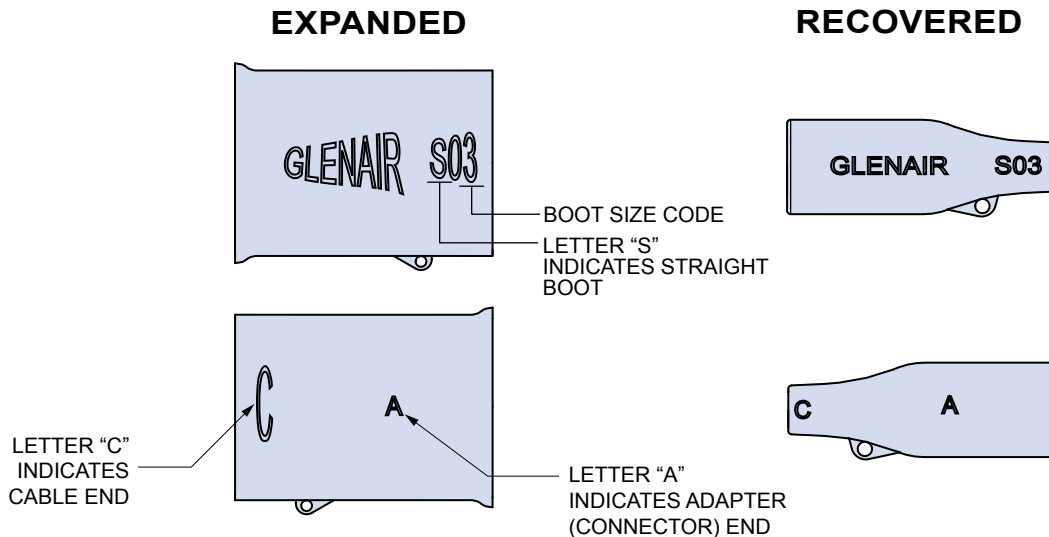

## PROCEDURE

The following general instructions are applicable to all Glenair heatshrink boots. Specific instructions for surface preparation, the use of adhesive and specific conditions for each molding material are given in the relevant sections following these general instructions.

### APPLICATION NOTE

When preheating of a connector or adaptor is required because of size then care should be taken not to damage any insulation or plastic material on either the connector or the wire insulation. Heat should only be applied to metal areas. **DO NOT PREHEAT COMPOSITE PARTS.**

### STEP 1: PLACE BOOT ON CABLE

Position the boot so that the lipped "A" end is toward the adapter and the "C" end is toward the cable .

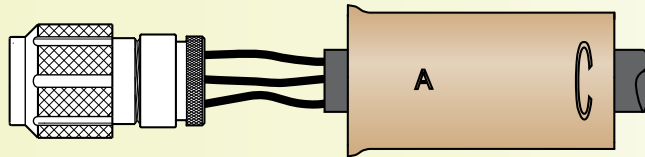

### STEP 2: APPLY HEAT TO ADAPTER END OF BOOT

Position the boot so that the lipped "A" end will recover into the groove of the adapter. Apply heat evenly around the boot at the adapter end. Ensure the boot is fully recovered and the lip fits into the groove of the adapter. This will take approximately 30 seconds for a size 04 or 05 boot, less for smaller parts and longer for larger boots.

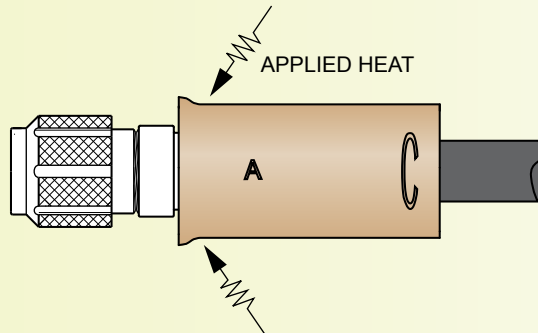

**STEP 3: CONTINUE APPLY HEAT TOWARD THE "C" END OF BOOT**

Great care must be taken to ensure the boot is not scorched or blistered or otherwise damaged during this process. The development of a high gloss is an indication that the part is reaching too high a temperature.

Continue to heat down the body of the boot towards the "C" end. Apply heat in brush-like strokes, ensuring the last part to recover is the "C" end. A feature of the Glenair boots is that, unlike other boots, they resist the tendency to fold over at the "C" end.

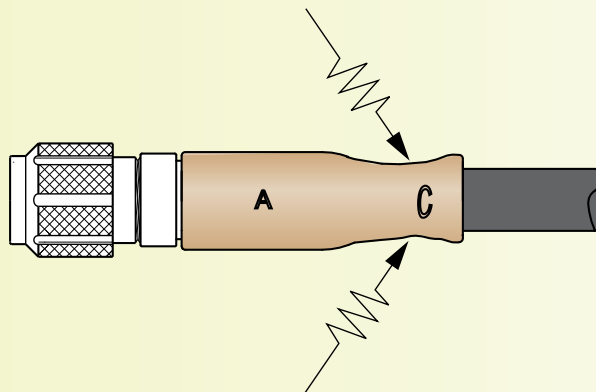
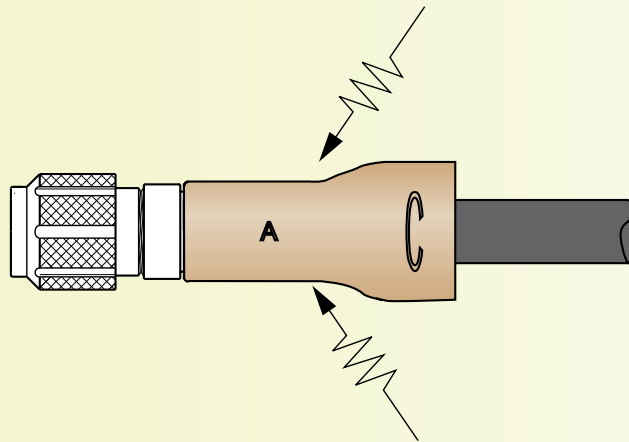



**STEP 4: AFTER BOOT IS FULLY RECOVERED, APPLY FURTHER HEAT TO "A" END**

After the boot is fully recovered, apply additional heat to the "A" and "C" ends to ensure adhesive melting and good adhesion. Typically this post heating will require 90-150 seconds depending on size. Care should be taken to avoid damaging the boot with excessive heat. Allow the parts to fully cool before handling.

**CAUTION**

The recovered parts will remain hot for some time and will be capable of burning skin if touched. Molten adhesive may also cause burns and adhere to exposed skin.

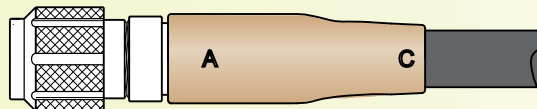

**STEP 5: INSPECTION OF INSTALLED HEATSHRINK BOOT**

1. The boot should be free of blisters, scorch marks and essentially free from distortion.
2. Any excessive adhesive should be removed.
3. The boot lip should be seated into the adapter groove, and the boot should be properly oriented.
4. A small fillet of adhesive should be visible between the boot and the cable jacket.
5. The termination should be subjected to a 90° flex test in each of the four planes around a mandrel with a diameter equal to 6X the cable diameter. Note: this is a flex test and not subjected to a tensile force. The joint should not be flexed until the boot has fully cooled and the adhesive cured.

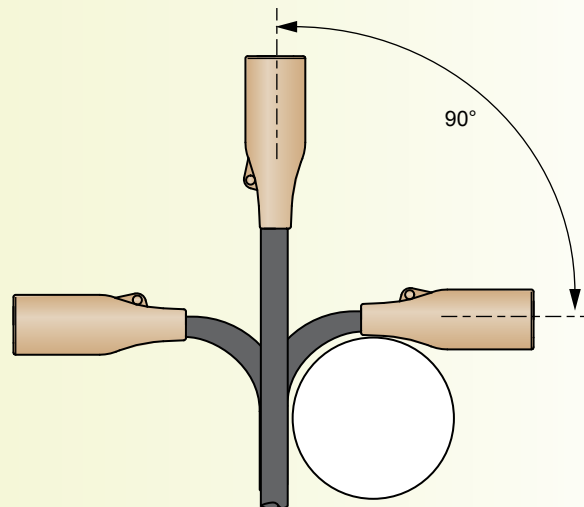

Octagonal junction box



How To Order

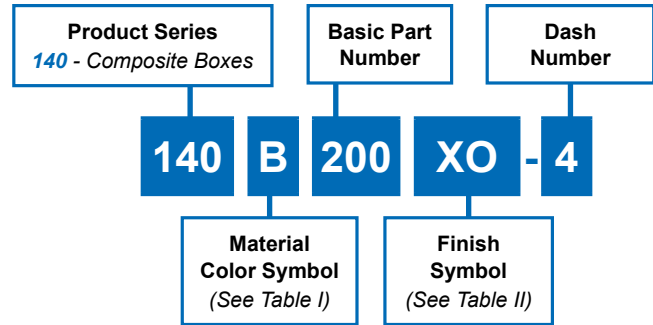

Table I - Finishes	
Symbol	Finish Description
XO	No Plating (Non-Conductive Finish)
XMS	Internal Surfaces - Electroless Nickel External Surfaces - See Table II
XM	All Surfaces - Electroless Nickel
XW	All Surfaces - Cadmium Olive Drab over Electroless Nickel
XZN	All Surfaces - Zinc Nickel/Black

Table II - Material Color & Finish		
Sym	Material & Color	Finish Options
B	Thermoplastic / Black	XO and XMS
G	Thermoplastic / Grey	XO and XMS
-	Thermoplastic / NA	XM, XW and XZN

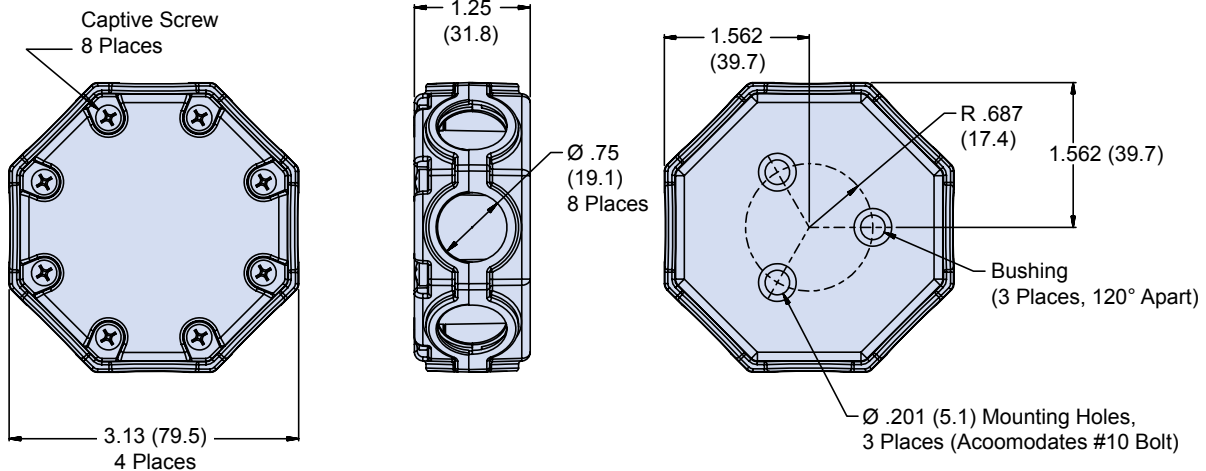
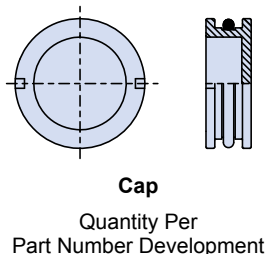

Table III - Key Dimensions		
Box Series Number	External Dimensions	Internal Dimensions (with Aluminum Mounting Plate installed, if applicable)
140-104 Mini	2.55 (64.8) × 3.85 (97.8) × 1.38 (35.1)	2.08 (52.8) × 3.38 (85.9) × 1.06 (26.9)



Notes

Use dash number 0000 for basic box with no additional options beyond your specified finish. 0000 basic box includes #6-32 UNC fasteners. Box series numbers are for reference only. Contact the factory for part number assignment for your specific box configuration.

# Series 140-108 12 Port Rectangular Junction Box



## 12 Port rectangular junction box

### How To Order

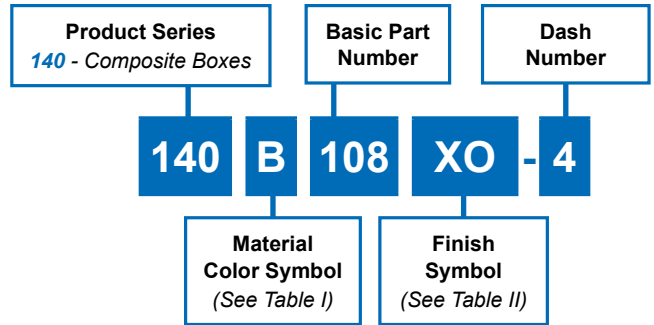

Symbol	Finish Description
XO	No Plating (Non-Conductive Finish)
XMS	Internal Surfaces - Electroless Nickel External Surfaces - See Table II
XM	All Surfaces - Electroless Nickel
XW	All Surfaces - Cadmium Olive Drab over Electroless Nickel
XZN	All Surfaces - Zinc Nickel/Black

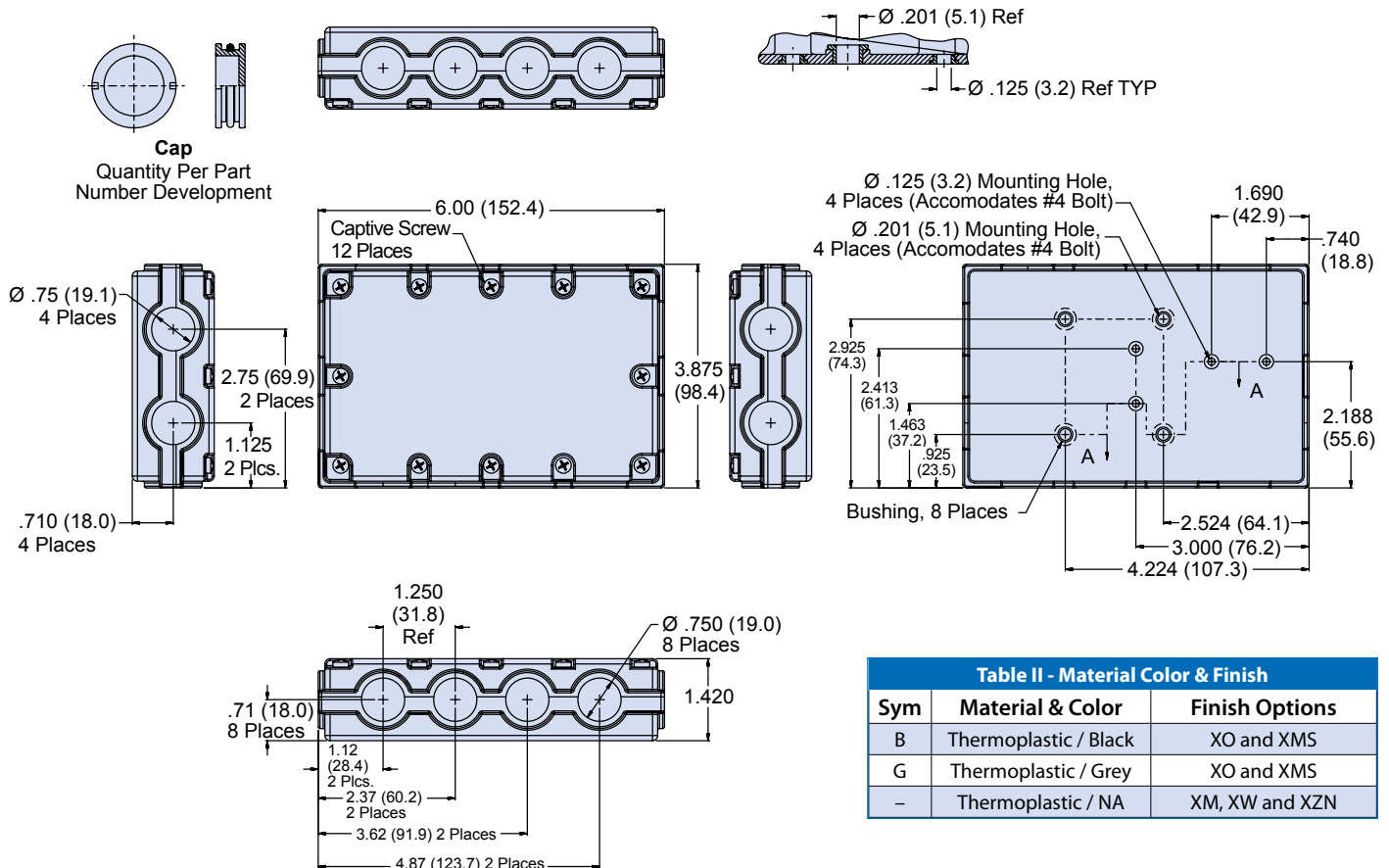

### Notes

Use dash number 0000 for basic box with no additional options beyond your specified finish. 0000 basic box includes #6-32 UNC fasteners.  
Box series numbers are for reference only. Contact the factory for part number assignment for your specific box configuration.

**Composite Guardian junction box adapter for use with 140-200 and 140-108 boxes**



**How To Order**

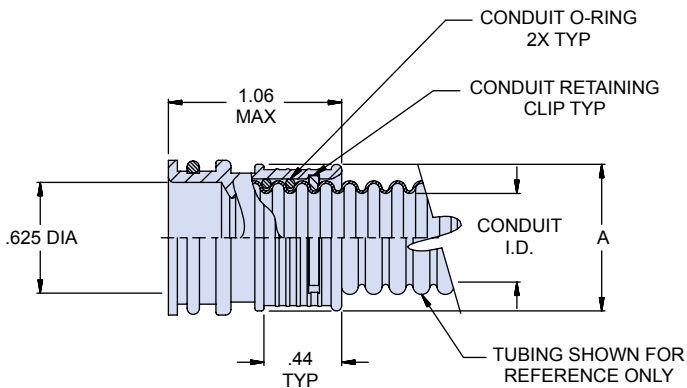
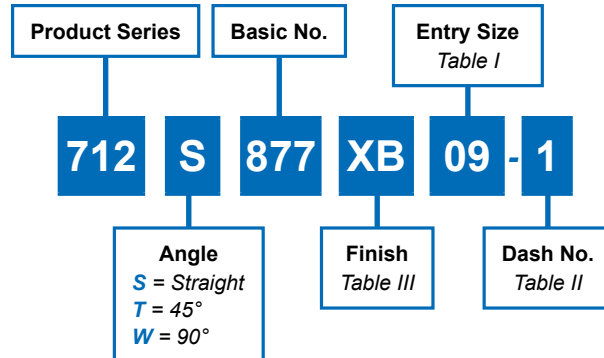

**Symbol S**  
**Straight,**  
**No Clocking**

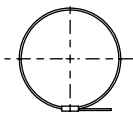

SYM K - BAND  
GLENAIR P/N 600-052-1

**Material and Finish**

O-rings: Silicone/NA  
Elbow, adapter: High grade engineering thermoplastic, black/see Table III  
Conduit retaining clip: High grade engineering thermoplastic, NA

**Tools and Assembly notes**

Master keyway angle for angular assemblies is measured with adapter body as shown  
Conduit retaining clip and conduit O-ring to be supplied unassembled  
Glenair assembly procedure AP74-010 is recommended for adapter to conduit termination  
Glenair 600 Series backshell assembly tools are recommended for assembly and installation

# 712-877 Composite Junction Box Adapter



Series 72  
Guardian

Entry Size	A Max	Conduit I.D.		Shrink Boot Ref
		Min	Max	
06	.53 (13.5)	.16 (4.1)	.19 (4.8)	770-001S103
09	.63 (16.0)	.24 (6.1)	.28 (7.1)	770-001S103
12	.73 (18.5)	.33 (8.4)	.37 (9.4)	770-001S104
16	.86 (21.8)	.45 (11.4)	.50 (12.7)	770-001S104
20	.98 (24.9)	.57 (14.5)	.62 (15.7)	770-001S105
24	1.15 (29.2)	.69 (17.5)	.75 (19.1)	770-001S106
28	1.27 (32.3)	.81 (20.6)	.87 (22.1)	770-001S107
32	1.40 (35.6)	.93 (23.6)	1.00 (25.4)	770-001S107

Dash No	B Deg
1	0
2	30
3	45
4	60
5	90
6	120
7	135
8	150
9	180
10	210
11	225
12	240
13	270
14	300
15	315
16	330

Symbol	Finish Description
XM	Electroless Nickel
XW	Cad/Olive Drab over Electroless Nickel
XB	Black color/Unplated

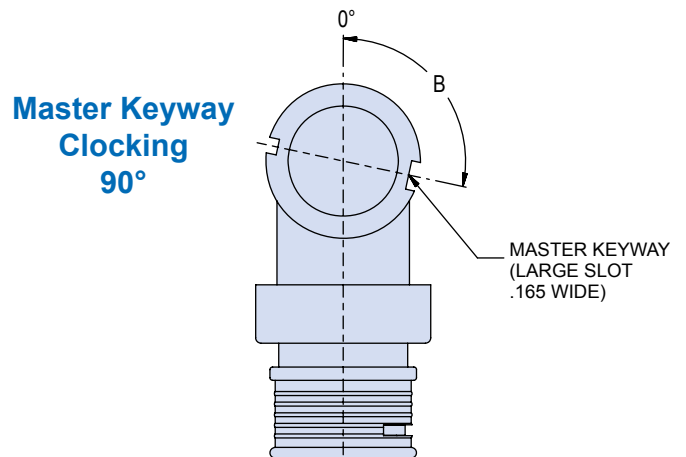
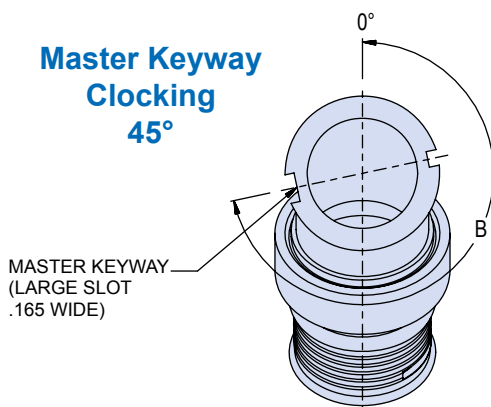
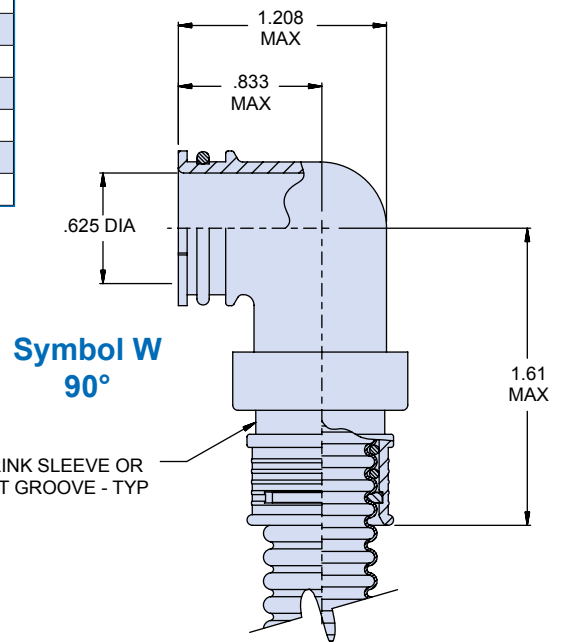
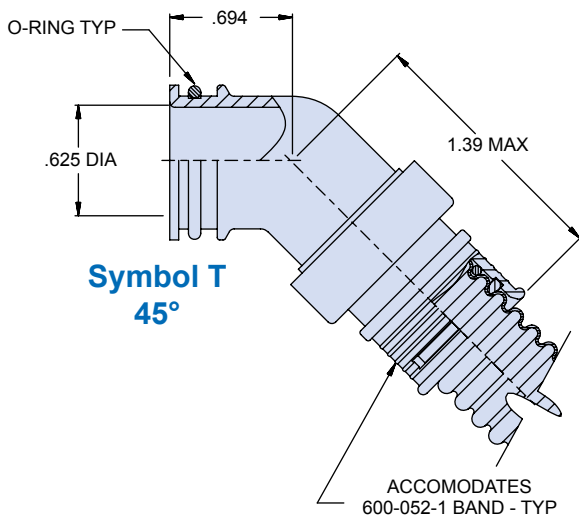

### **How-to-order factory terminated Guardian conduit assemblies**

The previous pages of this catalog allow you to order individual components and assemble your own conduit system. Did you know that Glenair can pre-assemble Guardian conduit systems for you? Glenair engineers can assemble point-to-point and multi-branch Guardian systems with connector adapters, bulkhead feed-thrus or transition terminations in a variety of finishes and angular configurations. Braided assemblies are supplied with BAND-IT® bands for EMI/RFI protection and shrink sleeves to protect the connector ends. Jacketed assemblies are supplied with shrink boots for environmental protection against contamination and moisture.

#### **Step 1**

Select conduit/jacket type (see pages 6-7 for overview) and pages 10-15 for detailed specifications.

#### **Step 2**

Factory terminated Guardian assemblies are available for all popular connector series, including rectangular and cylindrical, as well as for feed-thru and junction box applications. Select appropriate end fittings and adapters from the available choices presented on the following three pages.

#### **Step 3**

Use the provided "How To Order" trees (page 58) to create valid part numbers based on your "Step 1" and "Step 2" selections.

#### **Step 4**

Take advantage of Glenair's capabilities in material and plating categories by adding appropriate modification codes to the basic part number (see "Typical Mod Codes" table).

#### **Step 5**

For multi-legged assemblies, select appropriate transition fittings from pgs. 26-37



## Factory Terminated Guardian Assemblies How-To-Order



**G**uardian conduit assemblies can be terminated to metal or composite connector adapters or bulkhead feed-thrus in a variety of finishes. Jacketed assemblies are supplied with environmental shrink boots for optimal strain relief and protection against contaminants and moisture incursion.

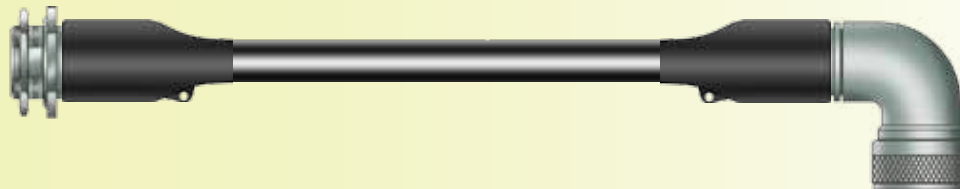

**C**onductor and feed-thru fittings can be supplied in straight, 45°, and 90° configurations on either end.

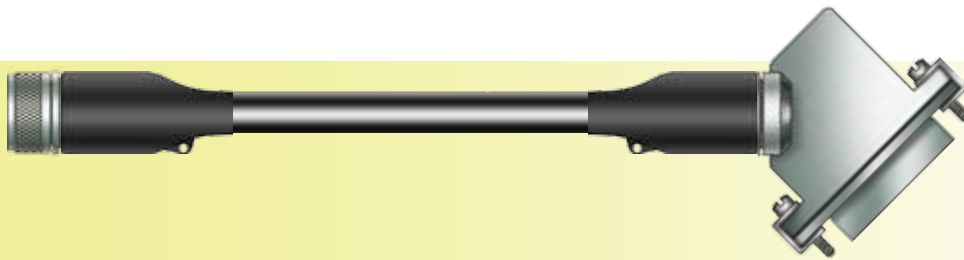

**R**ectangular connector adapters are also available in straight, 45°, and 90° configurations for D-Subminiature, Series 79 Micro-Crimp, or Micro-D connectors.

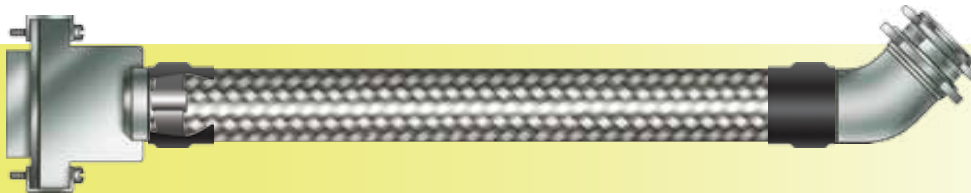

**T**his cutaway view shows band termination of conduit overbraid under the protective shrink sleeves that are supplied with all braided assemblies. The BAND-IT® band terminates the braid at the connector end for 360° EMI/RFI shielding.

# Turnkey Guardian Factory Assemblies



**G**lenair Series 72 Guardian Conduit Systems are ideally suited for convenient user assembly. However, many customers prefer the cost- and labor-saving advantages of having their Guardian System wire-protection assemblies pre-assembled at the Glenair factory. Glenair can terminate point-to-point or complex multi-branch assemblies to fit your specific application requirements. Our full-spectrum factory-terminated Guardian conduit assembly capability affords complete compatibility with virtually every type of electrical connector and interconnect system. Choose point-to-point or complex multi-branch systems, including straight, 45° and 90° adapter routings, and Y, T, double-Y and double-T transitions. In addition, Glenair is able to offer a wide range of jacketing and overbraiding technologies beyond those listed in the catalog. Contact the factory for more information.

#### Series 72 Conduit:

- Kynar® Conduit
- Tin/Copper Braid
- Neoprene Jacket

*Additional Conduit, Shield, and Jacket options shown on pages 10-15.*

## Turnkey! Let Glenair Build It For You

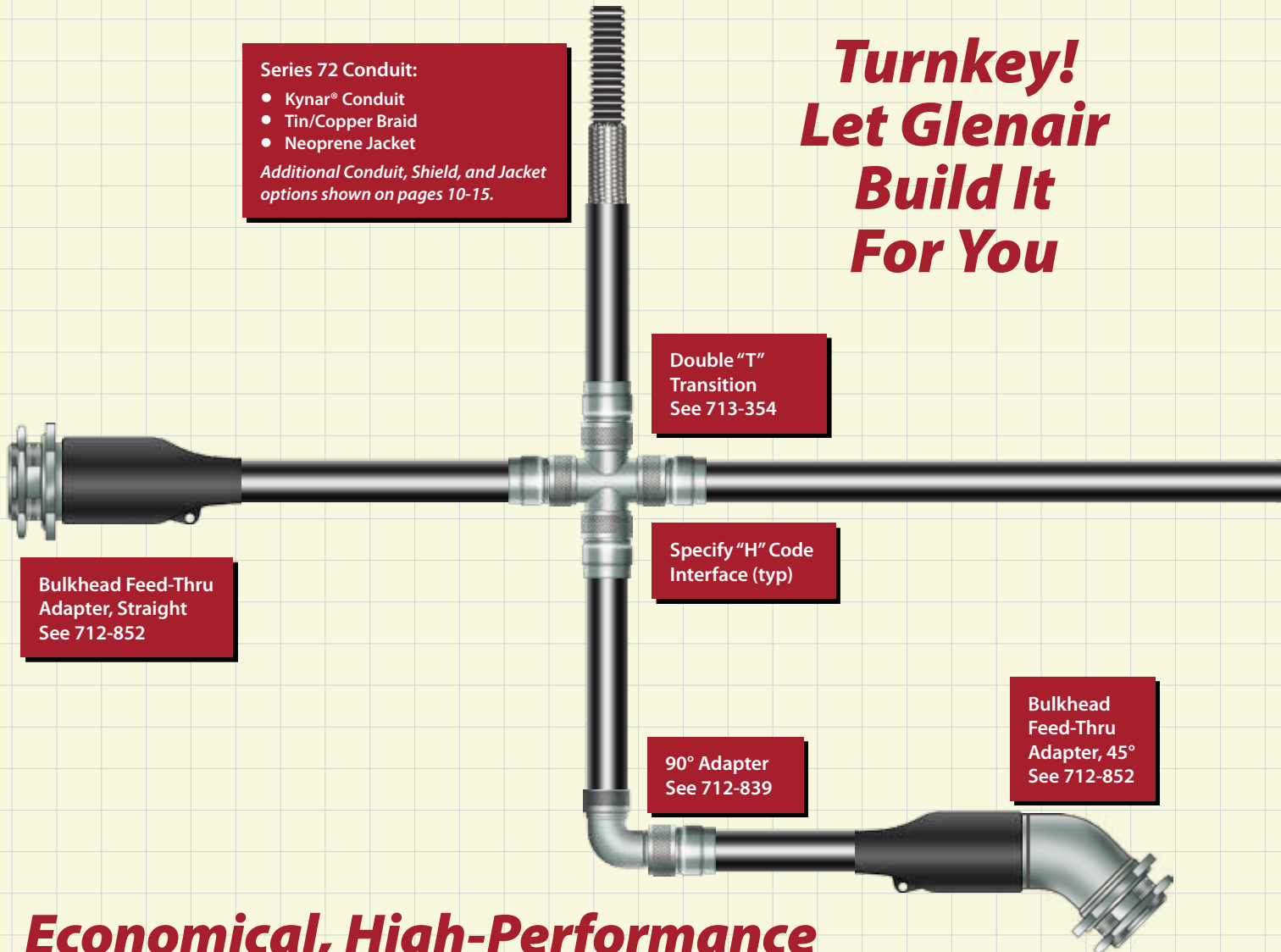

Bulkhead Feed-Thru  
Adapter, Straight  
See 712-852

Double "T"  
Transition  
See 713-354

Specify "H" Code  
Interface (typ)

90° Adapter  
See 712-839

Bulkhead  
Feed-Thru  
Adapter, 45°  
See 712-852

## Economical, High-Performance Conduit Wire Protection Systems

*(See next page for order information)*



# Point-to-Point or Multi-Branch

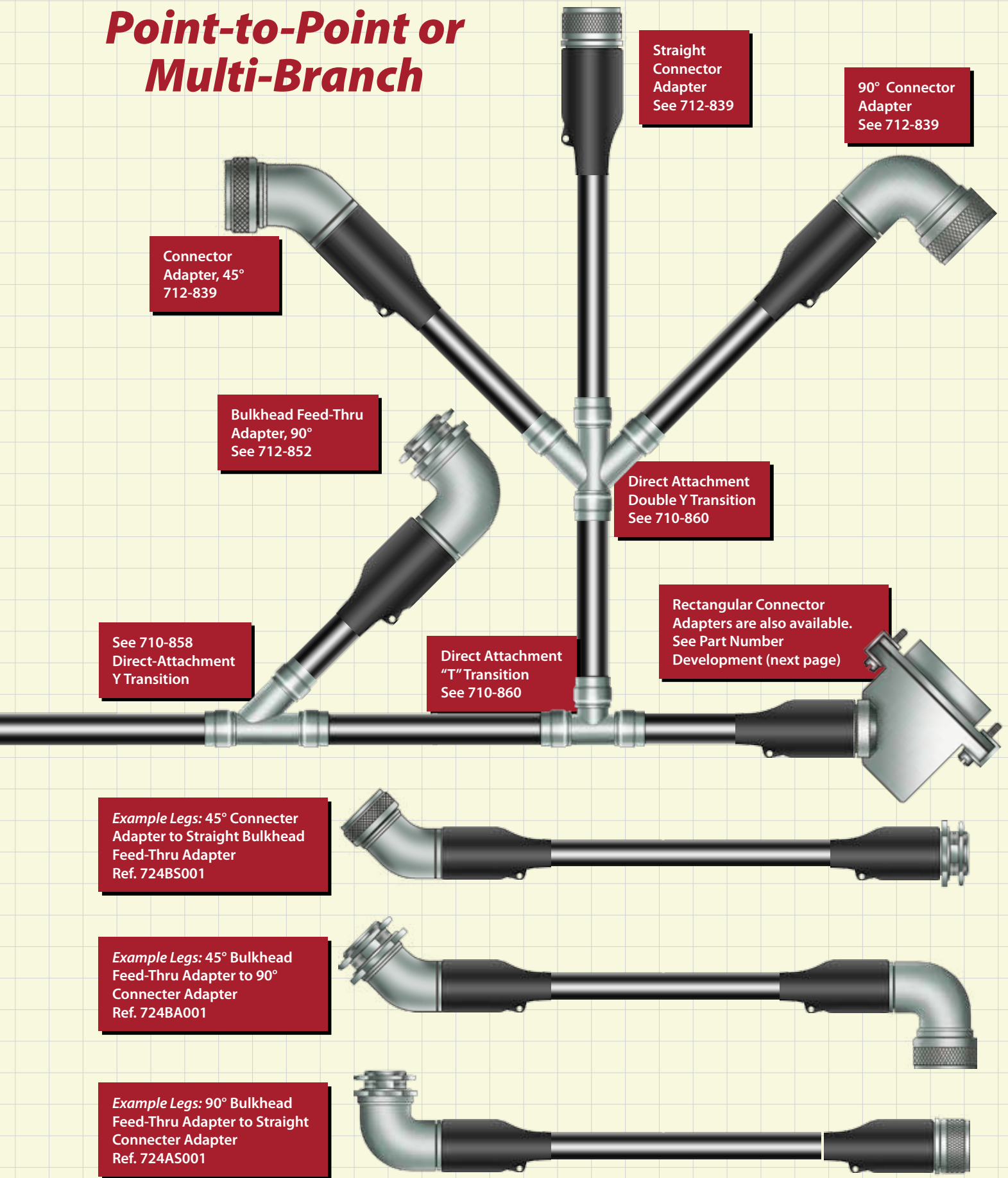

## Create a factory terminated Guardian assembly part number

Use the "order tree" to develop a comprehensive part number for the full range of Guardian System point-to-point factory terminated assemblies:

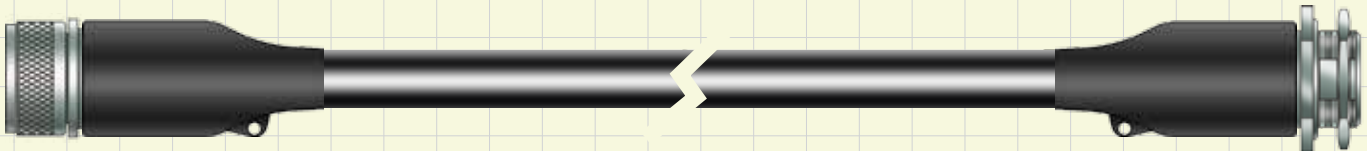

### How To Order

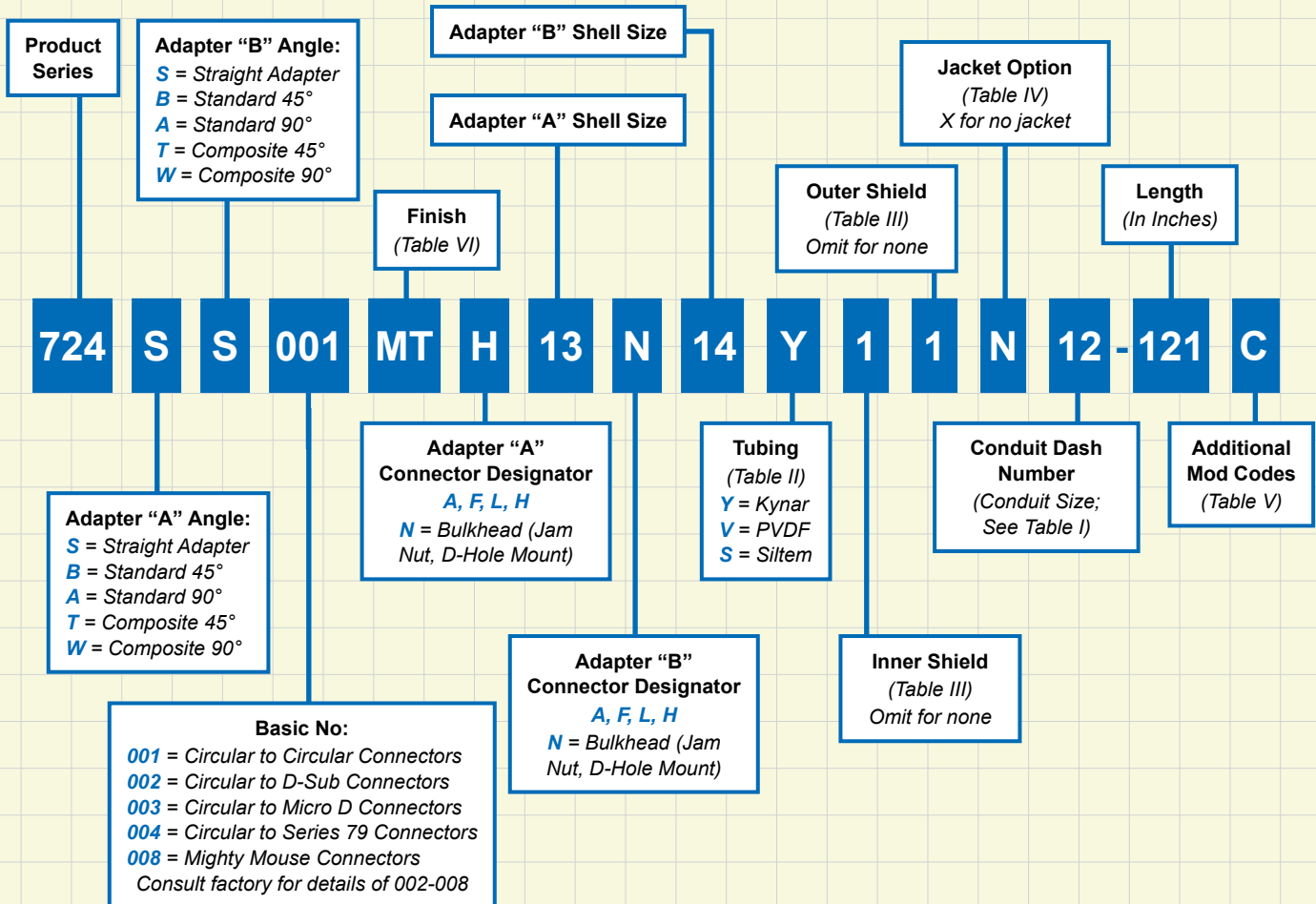

# Factory Terminated Guardian Assemblies How-To-Order



Series 72  
Guardian

Dash No.	Conduit I.D.	
	Min	Max
06	.16 (4.1)	.19 (4.8)
09	.24 (6.1)	.28 (7.1)
12	.33 (8.4)	.37 (9.4)
16	.45 (11.4)	.50 (12.7)
20	.57 (14.5)	.62 (15.8)
24	.69 (17.5)	.75 (19.1)
28	.81 (20.6)	.87 (22.2)
32	.93 (23.6)	1.00 (25.4)
40	1.18 (30.0)	1.25 (31.8)

<b>Y</b>	Kynar/Thermally stabilized
<b>V</b>	PVDF/Not thermally stabilized
<b>S</b>	Siltem/Medium duty

<b>1</b>	Tin/Copper
<b>4</b>	Stainless Steel
<b>2</b>	Nickel Copper
<b>8</b>	ArmorLite™
<b>7</b>	AmberStrand® 100%
<b>9</b>	AmberStrand® 75%/25%

<b>N</b>	Neoprene
<b>H</b>	Hypalon
<b>E</b>	EPDM
<b>V</b>	Viton
<b>B</b>	Duraelectric, Black
<b>G</b>	Bluejacket, Gray
<b>TN</b>	Duraelectric, Desert Tan
<b>D</b>	Dacron
<b>M</b>	Nomex

<b>A</b>	1 1/2 Extended adapter A
<b>B</b>	1 1/2 Extended adapter B
<b>C</b>	Teflon coated adapters
<b>D</b>	Dust cap receptacle adapter A
<b>E</b>	Dust cap receptacle adapter B
<b>F</b>	Dust cap plug adapter A
<b>G</b>	Dust cap plug adapter B
<b>L</b>	Drain wire (at connector ends)
<b>M</b>	Pull tape pre-installed
<b>N</b>	Floating blank ID tag w/clear
<b>T</b>	Strain relief boots
<b>U</b>	Jam nut bulkhead (w/o D-hole)
Max 3 mod codes per part number	

Sym	Material	Finish Description
<b>M</b>	Aluminum	Electroless Nickel
<b>MT</b>		Nickel-PTFE
<b>NF</b>		Cad/Olive Drab over Electroless Nickel
<b>ZN</b>		Zinc Nickel/Olive Drab over Electroless Nickel
<b>ZNU</b>		Zinc Nickel/Black over Electroless Nickel
<b>Z1</b>	Stainless Steel	Passivate
<b>XM</b>	Composite	Electroless Nickel
<b>XW</b>	Composite	Cad/Olive Drab over Electroless Nickel
<b>XB</b>	Composite	Black color/Unplated

## Notes

1. Length tolerance is  $\pm .250$  for lengths up to 24 inches. Length tolerance for longer lengths is  $\pm$  one percent (1%) of the length.

2. Transition fittings are used on adapter A for assemblies with 90° and/or 45° fittings on both sides to ease in wiring and to provide clocking between fittings. Part numbers 724AA001, 724BB200, 724AB001 include this transition fitting.

3. For additional bulkhead adapter options, see part numbers 713-362 & 713-363. Use code H for connector designator, which will act as a transition fitting that will mate to the 713-362 & 713-363 bulkhead adapters.

# Turnkey Factory (Crimp) Assemblies

In addition to factory terminated Guardian system assemblies (previous page) Glenair offers pre-terminated, *crimp-ring conduit assemblies* which deliver permanent, tamper-proof attachment to EMI shielding, jacketing and connector adapter fittings. Glenair can factory terminate point-to-point or complex multi-branch assemblies to fit your application. Our pre-terminated crimp-style conduit assemblies still allow easy access to contact terminations for routine maintenance and repair, but their robust crimp terminations prevent unauthorized tampering with the conduit/fitting assembly. They are ideally suited for applications where rough handling could expose wire media and connector terminations to environmental and EMI damage. Our full-spectrum factory-terminated conduit assembly capability affords complete compatibility with virtually every type of electrical connector and interconnect system.

#### Series 74 Conduit:

- PFA Conduit
- Tin/Copper Braid
- Neoprene Jacket

*Additional Conduit, Shield, and Jacket options available.*

## Glenair: Your Crimp- Terminated Conduit Assembly Solution

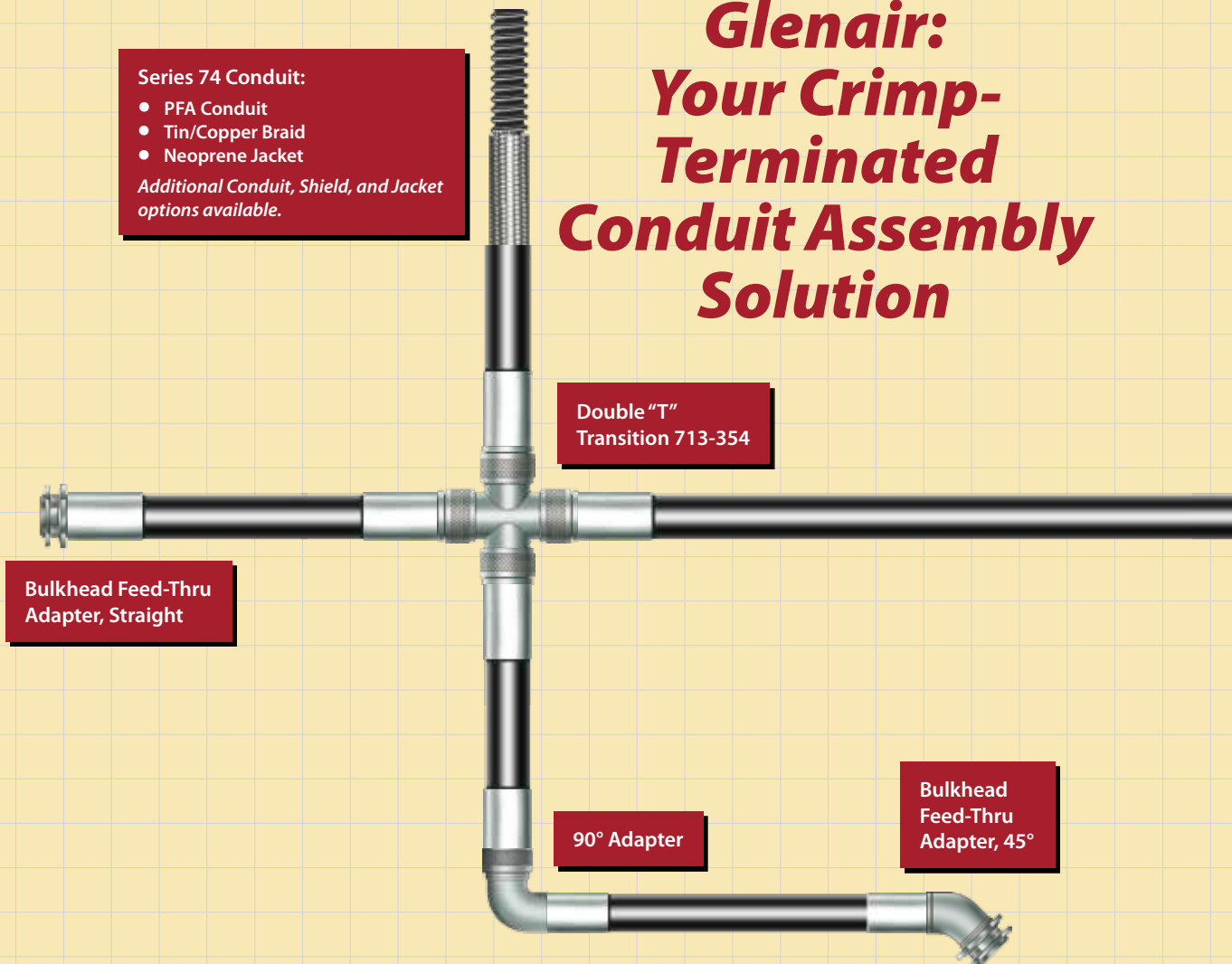

**High-Performance, Mission Critical  
Conduit Wire Protection Systems**  
*(Contact factory for order information)*

# Point-to-Point or Multi-Branch

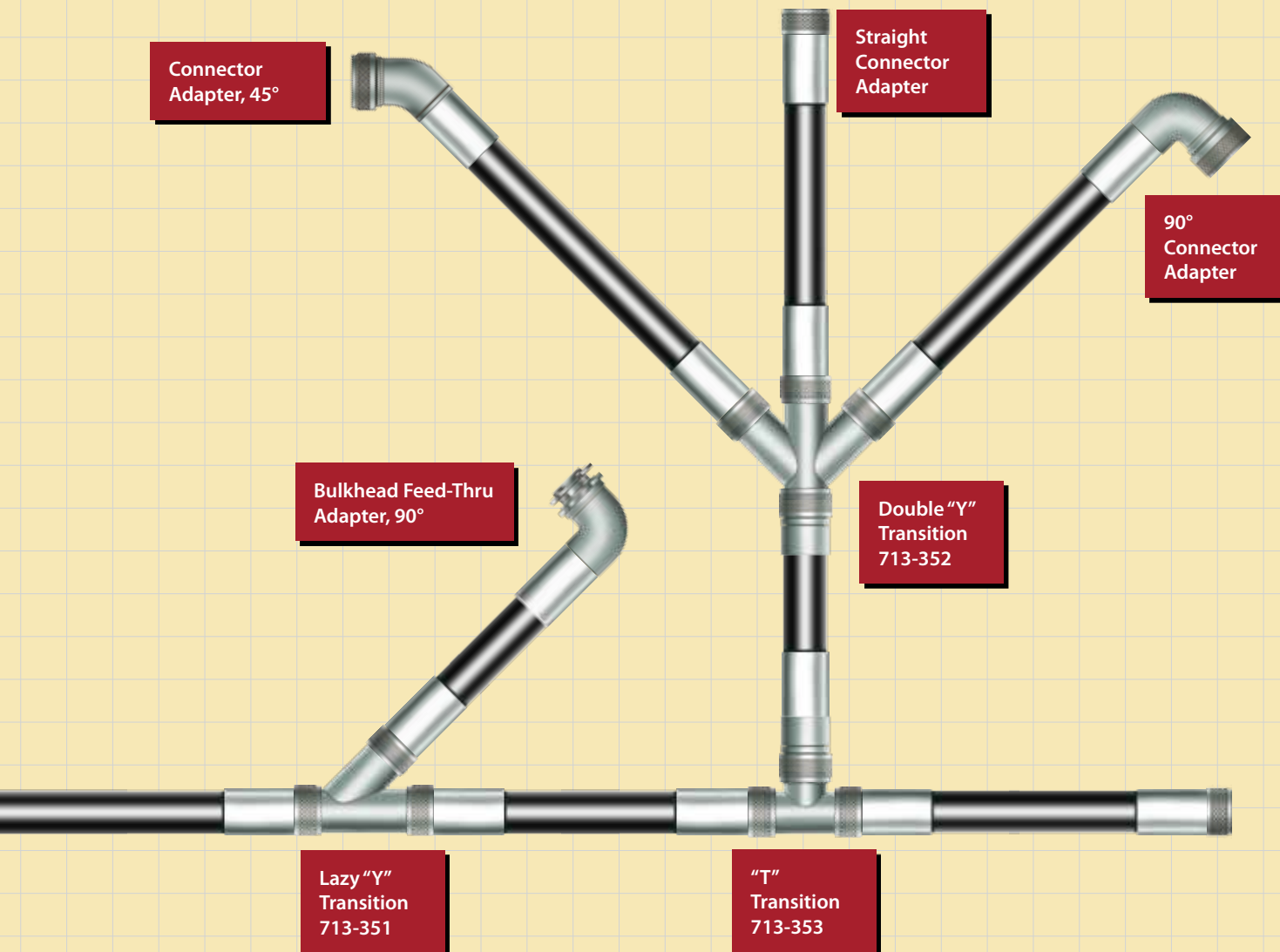

Example Legs: 45° Connector Adapter to Straight Bulkhead Feed-Thru Adapter

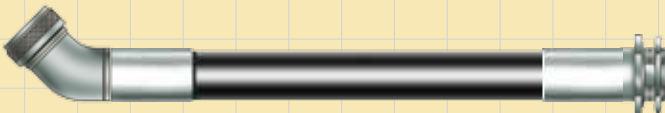

Example Legs: 45° Bulkhead Feed-Thru Adapter to 90° Connector Adapter

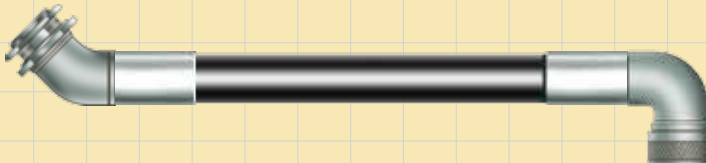

Example Legs: 90° Bulkhead Feed-Thru Adapter to Straight Connector Adapter



# **SEMPER TAN**

## **The Permanent FED-STD-33446 Desert Tan Solution**

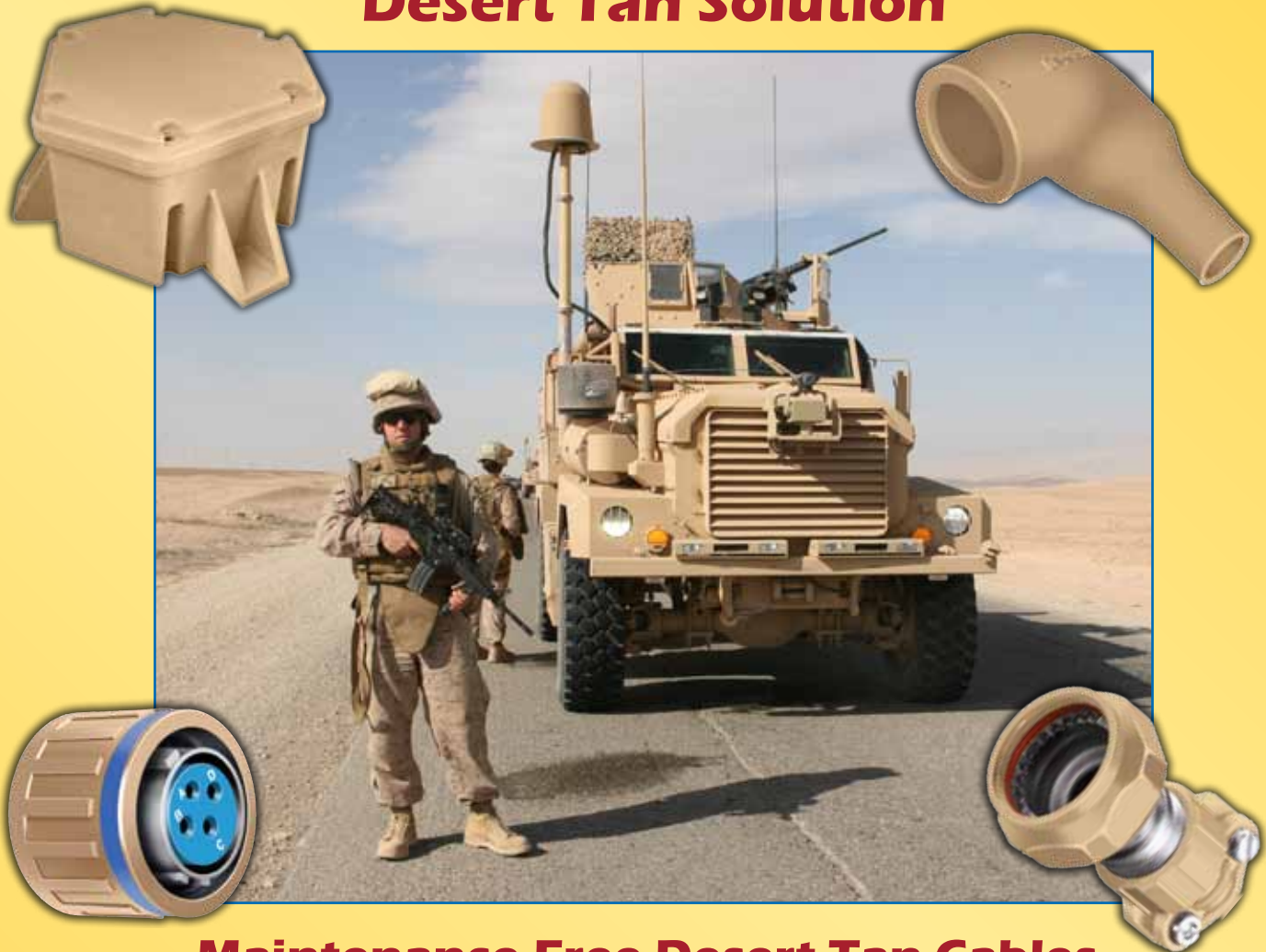

### **Maintenance-Free Desert Tan Cables, Conduits, Junction Boxes and More**

**R**ecently, one of our customers requested a Semper Tan version of our popular high-temperature annular tubing (hylar or trade name Kynar). Glenair was able to produce the product shown below in just a few short weeks and it is now being used in a military vehicle application. Semper Tan is the permanent FED-STD-33446 Desert Tan solution that eliminates the costly labor of manually painting and maintaining standard cables, conduit assemblies, and junction boxes used in military applications. Please consult the factory for innovative Semper Tan solutions.



*Hylar (trade name  
Kynar) Semper Tan  
annular tubing  
and Duraelectric  
Jacketing*



1211 Air Way · Glendale, California 91201-2497

Tel: 818-247-6000 · Fax: 818-500-9912 · E-mail: sales@glenair.com · www.glenair.com

United States · United Kingdom · Germany · Nordic · France · Italy · Spain · Japan

# WHY CHOOSE GLENAIR



Plenty of Materials Stock!



Outstanding  
Customer Service!



Abundant  
Extrusion Capacity!



In-House Assembly!



Huge "Same-Day" Inventory!

**G**lenair®



# A World of Interconnect Solutions

## Glenair, Inc.

1211 Air Way • Glendale, California • 91201-2497

Telephone: 818-247-6000 • Fax: 818-500-9912 • [sales@glenair.com](mailto:sales@glenair.com)

[www.glenair.com](http://www.glenair.com)

---

**Glenair Power  
Products Group**  
860 N. Main Street Extension  
Wallingford, CT  
06492

Telephone:  
203-741-1115  
Facsimile:  
203-741-0053  
[sales@glenair.com](mailto:sales@glenair.com)

---

**Glenair UK Ltd**  
40 Lower Oakham Way  
Oakham Business Park  
P.O. Box 37, Mansfield  
Notts, NG18 5BY England

Telephone:  
44-1623-638100  
Facsimile:  
44-1623-638111  
[sales@glenair.co.uk](mailto:sales@glenair.co.uk)

---

**Glenair Microway Systems**  
7000 North Lawndale Avenue  
Lincolnwood, IL  
60712

Telephone:  
847-679-8833  
Facsimile:  
847-679-8849

---

**Glenair Nordic AB**  
Gustav III : S Boulevard 46  
S - 169 27 Solna  
Sweden

Telephone:  
46-8-50550000  
Facsimile:  
46-8-50550001  
[sales@glenair.se](mailto:sales@glenair.se)

---

**Glenair Electric GmbH**  
Siemensstrasse 9  
D-61449 Steinbach  
Germany

Telephone:  
49-6171-5905-0  
Facsimile:  
49-6171-5905-90  
[germany@glenair.com](mailto:germany@glenair.com)

---

**Glenair Iberica**  
C/ La Vega, 16  
45612 Velada  
Spain

Telephone:  
34-925-89-29-88  
Facsimile:  
34-925-89-29-87  
[sales@glenair.es](mailto:sales@glenair.es)

---

**Glenair Italia S.R.L.**  
Via Santi, 1  
20037 Paderno Dugnano  
Milano, Italy

Telephone:  
39-02-9108-2121  
Facsimile:  
39-02-9904-3565  
[sales-italia@glenair.it](mailto:sales-italia@glenair.it)

---

**Glenair France SARL**  
7, Avenue Parmentier  
Immeuble Central Parc #2  
31200 Toulouse  
France

Telephone:  
33-5-34-40-97-40  
Facsimile:  
33-5-61-47-86-10  
[sales@glenair.fr](mailto:sales@glenair.fr)

